



OWNER'S MANUAL

PARTS & INSTALLATION MANUAL

VC620

Included in this manual:

VC620

- w/ Universal Subframe
- Capacity & Application Charts

VENCO VENTURO INDUSTRIES LLC
12110 BEST PLACE | CINCINNATI, OHIO 45241
800-226-2238



This manual also available online at www.venturo.com.

VC620

INST-620630 - 1/20/2025 (Rev: B0)

520951	INSTALLATION WARNINGS
520952	OPERATOR WARNINGS
516913	SECTION 200: INSTALLATION
620103	CAPACITY CHART, VC620
620104	CAPACITY CHART, VC620 (SUB-FRAME)
620122	MOUNTING DIMENSIONS
520938	UNIVERSAL SUB-FRAME FEATURES
416086	IMPORTANT INSTALLATION NOTICE
520604	HOIST MOUNTING INSTRUCTIONS
520605	HOIST MOUNTING INSTRUCTIONS
520609	HOIST MOUNTING INSTRUCTIONS
520093	INSTALLATION INSTRUCTIONS
662861	HINGE TO BED MOUNTING INSTRUCTIONS
520941	HOIST MOUNTING INSTRUCTIONS, UNIVERSAL SUB-FRAME
552009	SHEAR PLATE LOCATION
520608	MOUNTING ILLUSTRATION
620246	CABLE / HANDLE ASSEMBLY
416755	PTO PUMP CABLE INSTALLATION
416763	SPLIT PUMP
520621	SPDG HOSE CONNECTION DIAGRAM
416287	WILLIAMS PTO WARNING
416640	HYDRAULIC POWER UNIT GROUND CABLE INSTALLATION
6368	HYDRAULIC POWER UNIT GROUNDING
416809	40058M / MHD POWER UNIT
416869	HYD PORT LOCATIONS - KTI ES (40058)
416307	416081M ED POWER UNIT
416870	HYD PORT LOCATIONS - KTI ED (416081M)
416140	FILLING HYDRAULIC RESERVOIR
416128	DECAL LOCATIONS
516917	SECTION 250: OPERATION
520079	MAINTENANCE & OPERATION INSTRUCTIONS
416644	BODY PROP OPERATION GUIDE, GENERAL
416645	BODY PROP OPERATION GUIDE, ILLUSTRATIONS / INSTRUCTIONS
516914	SECTION 300: MAINTENANCE
520054	HOISTS GREASE POINTS
516915	SECTION 400: REPLACEMENT PARTS
628820	DECAL LIST
620119	REPLACEMENT PARTS DWG, VC620 HOIST
620120	REPLACEMENT PARTS LIST, VC620 HOIST
620133	REPLACEMENT PARTS DWG, VC620 HOIST W/ LINKAGE PROP
620134	REPLACEMENT PARTS LIST, VC620 HOIST W/ LINKAGE PROP
620117	REPLACEMENT PARTS DWG, VC620 PIVOTS
620118	REPLACEMENT PARTS LIST, VC620 PIVOTS
520939	REPLACEMENT PARTS DWG, VC416-620 UNIVERSAL SUB-FRAME
520940	REPLACEMENT PARTS LIST, VC416-620 UNIVERSAL SUB-FRAME
416308	REPLACEMENT PARTS DIAGRAM, 40058M /MHD POWER UNITS
416508	REPLACEMENT PARTS DIAGRAM, 416081M POWER UNITS
620245	REPLACEMENT PARTS DIAGRAM, PTO PUMP CABLE/CONSOLE
516919	USER NOTES
516919	USER NOTES

12-00073_VNC3 WARRANTY PAGE

READ THIS FIRST - INSTALLATION

USE THE BODY PROP

- ▶ NEVER work under a raised body without the use of the body prop. Body could inadvertently fall, causing death or serious injury.
- ▶ NEVER perform maintenance on a Hoist without applying the following:
 - ▶▶ Chassis brake set and engine turned off
 - ▶▶ Removing battery cable, if necessary
 - ▶▶ Properly deploying the Hoist body prop



INSTALLATION SAFETY REQUIREMENTS

- ▶ Cover all fuel related items (hoses, brake lines, wiring, etc.) so as not to cause fire or explosions that will result in serious injury or death.
- ▶ Route all wiring and hoses away from exhaust systems. Heat from exhaust systems can cause melting of wiring and hoses, resulting in fire and/or explosions that could result in serious injury or death.
- ▶ Hydraulic system must be designed to work within the manufacturer's specifications. Systems with more flow or PSI can cause hoist to fail during the dumping of a load; which could cause damage, serious injury or death.
- ▶ Always wear eye protection and protective clothing when working around hydraulic systems. Fluid under pressure can pierce the skin and enter the bloodstream, causing serious injury or death.

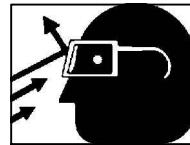

IMPORTANT INSTALLATION REQUIREMENTS

- ▶ Read and fully understand entire owner's manual prior to installation.
- ▶ Refer to Body Builder's Guide BEFORE welding or drilling on chassis as not to void the chassis warranty.
- ▶ When drilling the chassis make sure all brake lines, wire harnesses, and hoses are protected so as not to cause damage to these items resulting in failure. All fasteners must be installed so they do not interfere with these items as well.
- ▶ NEVER adjust factory relief valve settings without consulting with the factory.



VENCO VENTURO INDUSTRIES LLC
CINCINNATI, OHIO

TITLE
INSTALLATION WARNINGS

HOISTS

DATE
12-11-23C

SUPERSEDES
11-07-23B

SECTION

-

520951

READ THIS FIRST - OPERATION

USE THE BODY PROP

- ▶ When performing maintenance, truck should be turned off and the emergency brake set along with the body prop set under an UNLOADED body. NEVER prop a loaded body. Body could inadvertently fall, causing death or serious injury.
- ▶ NEVER work under a raised body without the use of the body prop. Body could inadvertently fall, causing death or serious injury.

 **DANGER**

WILL RESULT IN SERIOUS INJURY
OR DEATH



DUMP SAFETY

- ▶ Overloading Hoist can cause equipment malfunction, which will cause serious injury or death.
- ▶ Venco hoists are designed for and intended to be used on stationary trucks, dumping on firm and level ground. Spreading applications and/or shock-unloading are strictly prohibited. Failure to follow these guidelines could result in serious injury or death.
- ▶ Do not dump while on uneven ground or if vehicle is uneven side to side. Dumping while uneven can cause vehicle to overturn and cause property damage, equipment damage, serious injury or death.
- ▶ Stay clear of dump body when dumping. Moving vehicle parts or the moving load could cause serious injury or death.
- ▶ NEVER operate this Hoist from outside the cab. This could cause serious injury or death.

 **WARNING**

CAN RESULT IN SERIOUS INJURY
OR DEATH



UNDERSTAND YOUR EQUIPMENT

- ▶ Read and fully understand entire owner's manual prior to operating this equipment.
- ▶ Only allow qualified personnel to work on this equipment that understands its functions.
- ▶ Make sure all warning and caution labels are legible and properly placed. Refer to the installation section for placement and the replacement parts section for replacement decals.
- ▶ We strongly recommend you contact your truck equipment distributor to perform any type of repair or maintenance on your equipment. If you do not have a local distributor, call VENCO VENTURO INDUSTRIES LLC for the closest authorized distributor.

 **CAUTION**

COULD RESULT IN MINOR OR
MODERATE INJURY



VENCO VENTURO INDUSTRIES LLC
CINCINNATI, OHIO

TITLE
OPERATOR WARNINGS

HOISTS

DATE
12-11-23B

SUPERSEDES
11-07-23A

SECTION
-
520952

SECTION 200

INSTALLATION



VENCO VENTURO INDUSTRIES LLC
CINCINNATI, OHIO

VENCO HOIST MODEL VC620

CAPACITIES ARE BASED ON WATER LEVELS AND NON-DIMINISHING LOADS. DUE TO THE VARIATIONS IN TRUCK EQUIPMENT AND CAB-AXLE LENGTHS (CA), *THE DATA PROVIDED ON THIS PAGE IS TO BE USED AS A GUIDELINE ONLY.*

DUMP CLASS: 40

CONVERSION CLASS: D

WEIGHT: 595 LBS.

POWER SOURCE:

- ES - ELECTRIC SINGLE ACTING
- ED - ELECTRIC DOUBLE ACTING
- PD - POWER TAKE OFF DOUBLE ACTING

ADDITIONAL DATA:

- 6" BORE x 20" STROKE
- CA: 84" - 138"
- DUMP ANGLE: 40° - 50°
- MOUNTING HEIGHT REQ'D: 8"

CONVERSION APPLICATIONS VC620					
BODY	CA	OH	40° (TON)	45° (TON)	50°(TON)
13'	84"	42"	24.0	21.4	19.4
13'	102"	24"	16.0	14.3	12.9
13'	108"	18"	14.4	12.9	11.6
13'	114"	12"	13.1	11.7	10.6
13'	120"	6"	12.0	10.7	9.7
14'	102"	36"	18.0	16.1	14.5
14'	108"	30"	16.0	14.3	12.9
14'	114"	24"	14.4	12.9	11.6
14'	120"	18"	13.1	11.7	10.6
14'	124"	14"	12.4	11.0	10.0
14'	126"	12"	12.0	10.7	9.7
15'	102"	48"	20.6	18.4	16.6
15'	108"	42"	18.0	16.1	14.5
15'	114"	36"	16.0	14.3	12.9
15'	120"	30"	14.4	12.9	11.6
15'	124"	26"	13.5	12.0	10.9
15'	126"	24"	13.1	11.7	10.6
15'	138"	12"	11.1	9.9	8.9
16'	114"	48"	18.0	16.1	14.5
16'	120"	42"	16.0	14.3	12.9
16'	124"	38"	14.9	13.3	12.0
16'	126"	36"	14.4	12.9	11.6
16'	138"	25"	12.0	10.7	9.7
16'	144"	18"	11.1	9.9	8.9

DUMP BODY APPLICATIONS VC620 *					
BODY	CA	O.H.	40° (TON)	45° (TON)	50°(TON)
8'	-	12"	24.0	21.4	19.4
9'	-	12"	20.6	18.4	16.6
10'	-	12"	18.0	16.1	14.5
12'	-	12"	14.4	12.9	11.6

* VENCO hoists are designed for and intended to be used on stationary trucks dumping on firm and level ground. Spreading applications and/or shock unloading are strictly prohibited and will void this warranty.



VENCO VENTURO INDUSTRIES LLC
CINCINNATI, OHIO

TITLE
CAPACITY CHART
VC 620 HOIST

DATE
11-06-15D
SUPERSEDES
01-22-15C

SECTION
H200 ▲
620103

VENCO HOIST MODEL VC620 W/ SUBFRAME

CAPACITIES ARE BASED ON WATER LEVELS AND NON-DIMINISHING LOADS. DUE TO THE VARIATIONS IN TRUCK EQUIPMENT AND CAB-AXLE LENGTHS (CA), *THE DATA PROVIDED ON THIS PAGE IS TO BE USED AS A GUIDELINE ONLY.*

DUMP CLASS: 40

CONVERSION CLASS: D

WEIGHT: 825 LBS.

POWER SOURCE:

- ES - ELECTRIC SINGLE ACTING
- ED - ELECTRIC DOUBLE ACTING
- PD - POWER TAKE OFF DOUBLE ACTING

ADDITIONAL DATA:

- 6" BORE x 20" STROKE
- CA: 84" - 138"
- DUMP ANGLE: 45° - 50°
- MOUNTING HEIGHT REQ'D: 6-7/8"

CONVERSION APPLICATIONS VC620 W/ SUBFRAME				
BODY	CA	OH	45° (TON)	50°(TON)
13'	84"	42"	21.8	19.7
13'	102"	24"	14.5	13.1
13'	108"	18"	13.1	11.8
13'	114"	12"	11.9	10.7
13'	120"	6"	10.9	9.9
14'	102"	36"	16.3	14.8
14'	108"	30"	14.5	13.1
14'	114"	24"	13.1	11.8
14'	120"	18"	11.9	10.7
14'	124"	14"	11.2	10.1
14'	126"	12"	10.9	9.9
15'	102"	48"	18.7	16.9
15'	108"	42"	16.3	14.8
15'	114"	36"	14.5	13.1
15'	120"	30"	13.1	11.8
15'	124"	26"	12.2	11.1
15'	126"	24"	11.9	10.7
15'	138"	12"	10.0	9.1
16'	114"	48"	16.3	14.8
16'	120"	42"	14.5	13.1
16'	124"	38"	13.5	12.2
16'	126"	36"	13.1	11.8
16'	138"	25"	10.9	9.9
16'	144"	18"	10.0	9.1

DUMP BODY APPLICATIONS VC620 W/ SUBFRAME *				
BODY	CA	O.H.	45° (TON)	50°(TON)
8'	-	12"	21.8	19.7
9'	-	12"	18.7	16.9
10'	-	12"	16.3	14.8
12'	-	12"	13.1	11.8

* VENCO hoists are designed for and intended to be used on stationary trucks dumping on firm and level ground. Spreading applications and/or shock unloading are strictly prohibited and will void this warranty.



VENCO VENTURO INDUSTRIES LLC
CINCINNATI, OHIO

TITLE
CAPACITY CHART
VC 620 HOIST W/ SF

DATE
11-06-15E
SUPERSEDES
01-22-15D

SECTION
H200 ▲
620104

VC620 HOIST (NON-SUBFRAME)

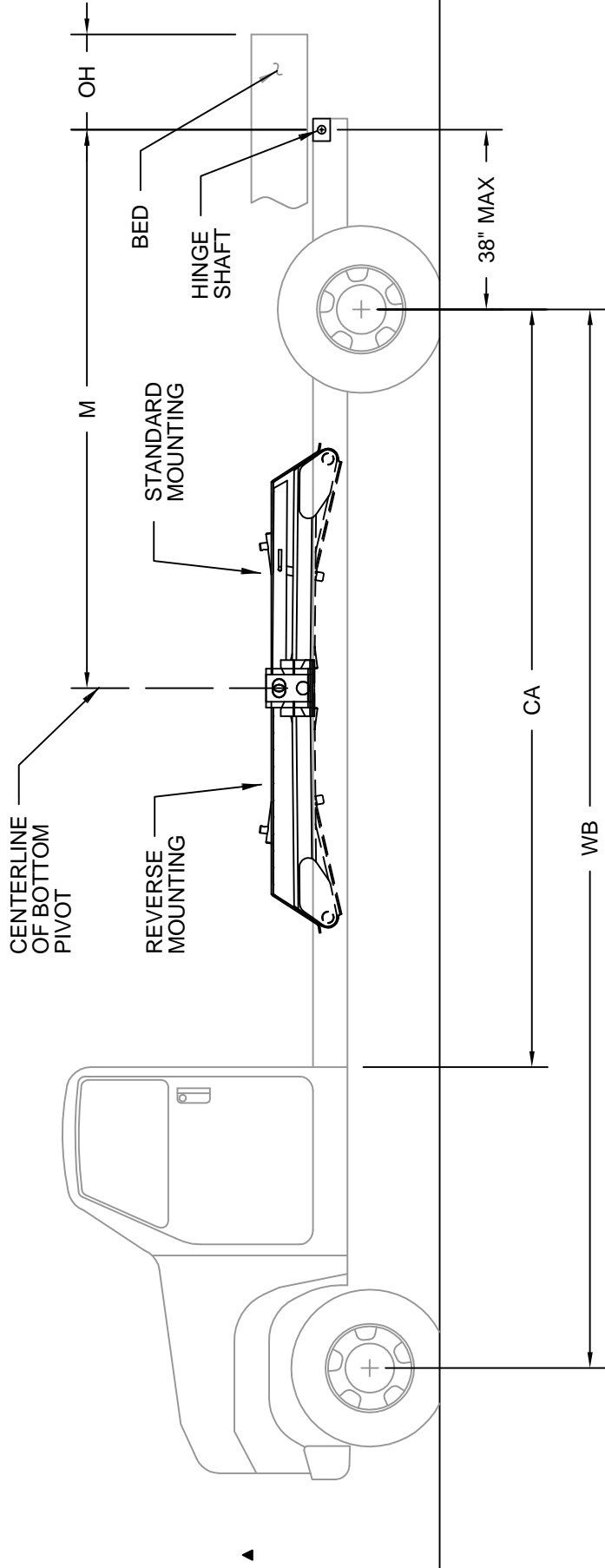

STANDARD / REVERSE MOUNTING

DUMP ANGLE	M
40°	102"
45°	91"
50°	83"

FIGURE 1.A

 Venco VENTURO INDUSTRIES LLC CINCINNATI, OHIO	TITLE	MOUNTING DIMENSIONS	
	VC620 HOIST (NON-SUBFRAME)		
DATE	11-09-15B	SECTION	H200
SUPERSEDES	06-18-03		620122

NOTE: THE CROSSMEMBER / HYDRAULIC POWER UNIT MOUNTING BRACKET ACCOMMODATES **ES** & **ED** POWER UNITS. THE CROSSMEMBER IS **'FACTORY INSTALLED'** ON THE MAIN SUBFRAME AS SHOWN BELOW AND IS SET UP FOR AN **'ED'** HYDRAULIC POWER UNIT. IF SUBFRAME EXTENSIONS ARE USED, YOU CAN MOUNT THE POWER UNIT TO THE EXTENSIONS AS SHOWN.

NOTE: FOR **ES** POWER UNITS YOU MUST RELOCATE THE CROSSMEMBER TO THE **ES** MOUNTING SLOT POSITION AS SHOWN BELOW OR SWAP ENDS OF THE CROSSMEMBER TO SUIT.

NOTE: THE SCISSORS SUPPORT CROSSMEMBER CAN BE POSITIONED TO SUPPORT VC416 THRU VC620 MODEL HOISTS.

NOTE: THIS SUPPORT KEEPS THE HOIST **'LEVEL'** FOR OPTIMUM PERFORMANCE AND REDUCED WEAR.

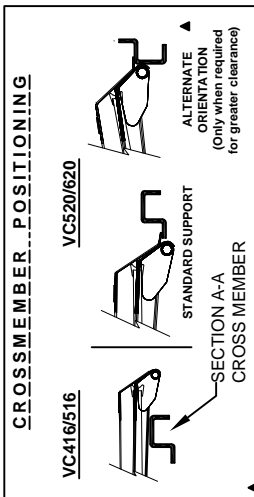

CAUTION

VC416, VC516, & VC520 ONLY

The alternate orientation shown above must be used if any portion of the hoist operation interferes with the vehicle's structure and/or components.

CROSSMEMBER POSITIONING

ROCKER STYLE REAR HINGES - ACCOMMODATES ALL TYPES OF BODY RAILS INCLUDING TRAPEZOIDAL & C-CHANNEL.

2012+ FORD SUPER DUTY REAR SHEAR PLATE W/ MATCHING CHASSIS HOLE/BOLT PATTERN.

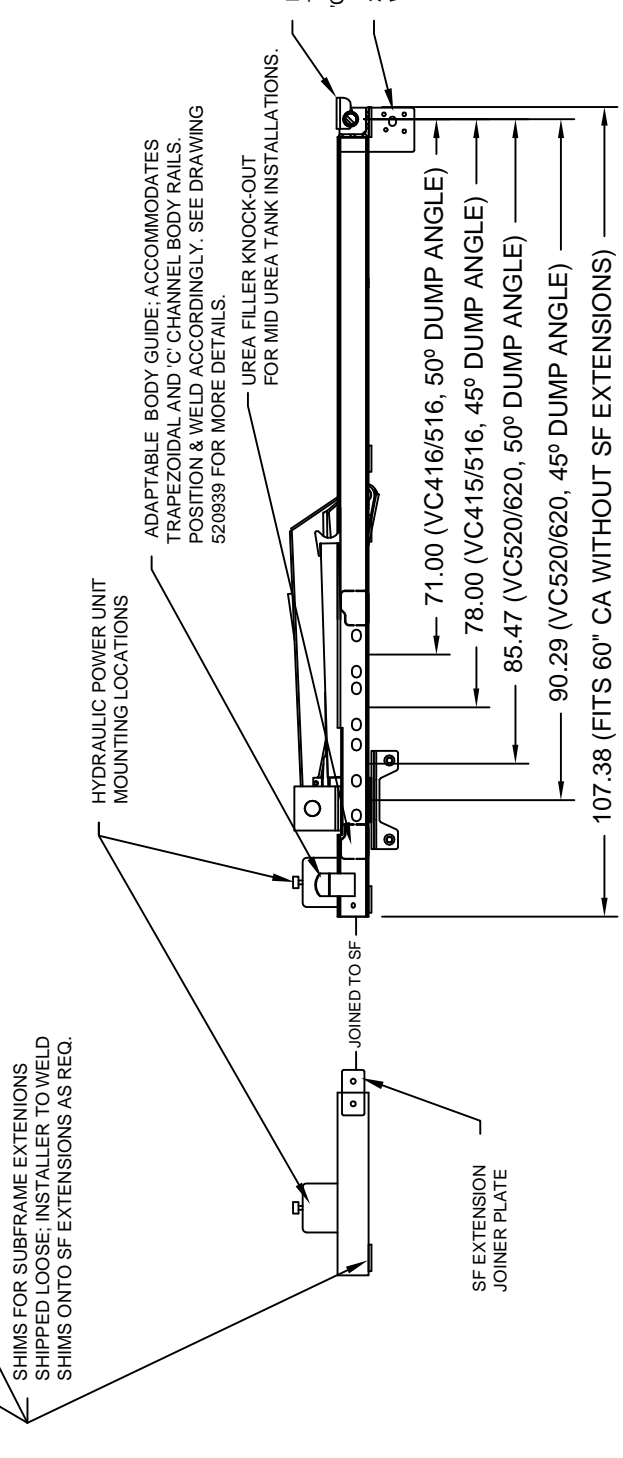
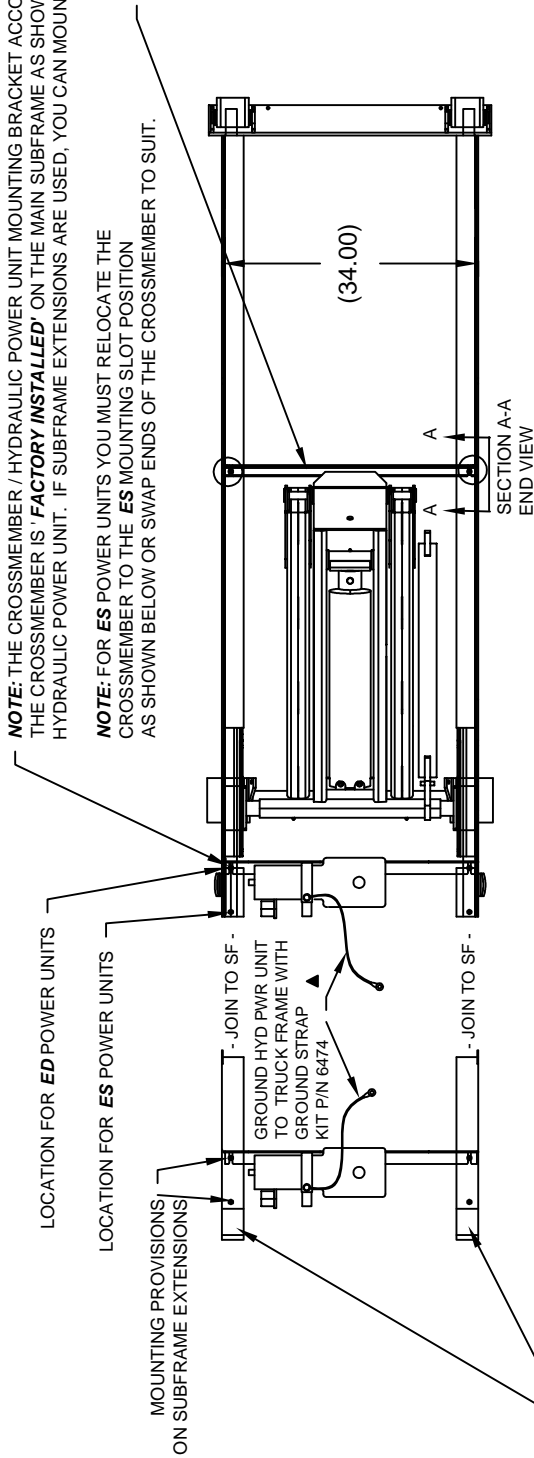

UNIVERSAL SUBFRAME SPECIFICATIONS

HOIST MODEL	DUMP ANGLE	CA W/ NO SF EXTENSIONS	CA W/ SF EXTENSIONS
VC416/516	45° & 50°	60"	84", 108" & 120"
VC520/620	47° & 50°	60"	84", 108" & 120"



VENCO VENTURO INDUSTRIES LLC
CINCINNATI, OHIO

TITLE
UNIVERSAL SUB-FRAME FEATURES

VC416 - VC620 HOISTS

DATE
07-07-17J

SUPERSEDES
04-27-16H

SECTION
-

520938

!! IMPORTANT WARNING !!

* ALL VENCO CONVERSION HOISTS → VC416 THRU VC6628 *

1

When installing the hoist, be sure to keep the hoist on a horizontal plane - LEVEL - with the truck frame.

VC416 / VC516

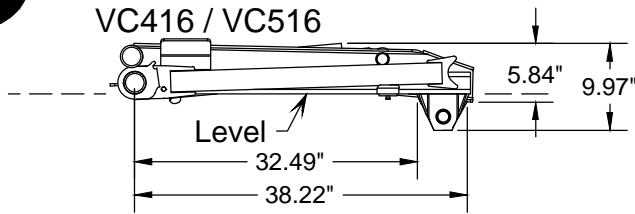

VC628

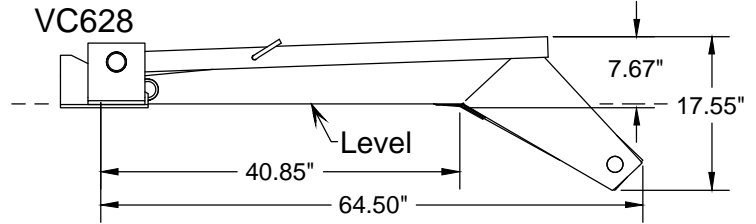

VC520 / VC620 (620200)

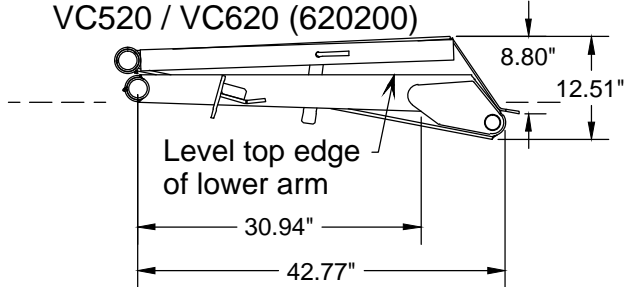

VC5520 / VC6620

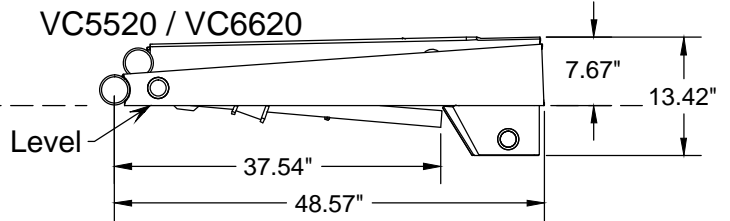

VC6628

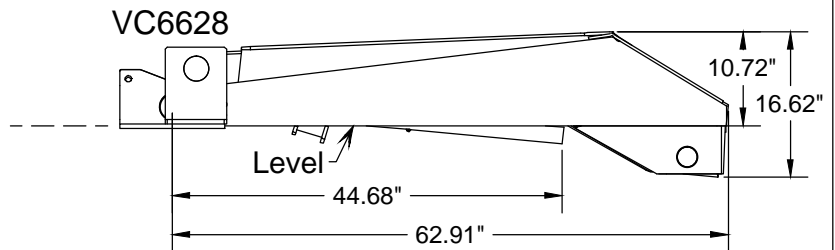

2

!! IMPORTANT !!

A minimum clearance of 2" is required between the hoist (upper arm) and the body cross-members in order to prevent a mechanical lockout. If clearance is less than 2", then cross-members must be notched above arms.

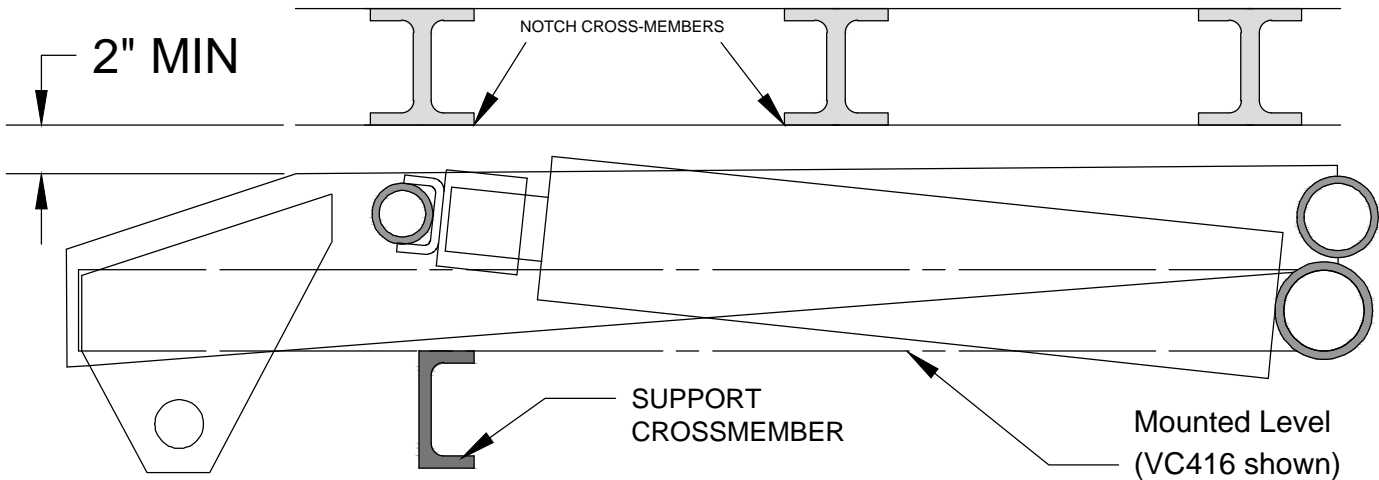

!! IMPORTANT !!

THE HOIST SCISSOR MUST BE SUPPORTED WITH A CHASSIS-MOUNTED SUPPORT CROSSMEMBER. IF THE TRUCK CHASSIS DOES NOT HAVE A CROSSMEMBER TO SUPPORT THE HOIST IN A 'LEVEL' POSITION, THE INSTALLER 'MUST' INSTALL A SUPPORT CROSSMEMBER AS SHOWN ABOVE.



VENCO VENTURO INDUSTRIES LLC
CINCINNATI, OHIO

TITLE
IMPORTANT WARNING

DATE
12-08-20P

SECTION
H200

VENCO HOISTS

SUPERSEDES
11-05-15N

416086

HOIST MOUNTING INST. - VC520/620 NON-SUBFRAME

▲ Refer to Capacity Chart drawings 520601, 620103 (as applicable per hoist model).

! CAUTION !

- If the distance between the center of the rear axle and the rear hinge assembly exceeds 38", additional reinforcement of the truck frame is necessary

- A. Mark the location for the rear hinge. Ideally, this location will be immediately behind a truck cross member, approximately 38" behind the center of the rear axle on a single axle truck. (see drawing 520603 or 620122)
- B. Cut a 90° slot in each side of the frame as shown in Figure 2 below.
- ▲ C. Position the angle iron frame of the rear hinge assembly in the truck frame cut-outs. Make sure the rear hinge assembly is properly positioned on the truck frame. Weld all around truck frame rear hinge assembly joint (both sides). See DWG 662861 for information regarding the mounting of the Rear Hinge Brackets to the body.

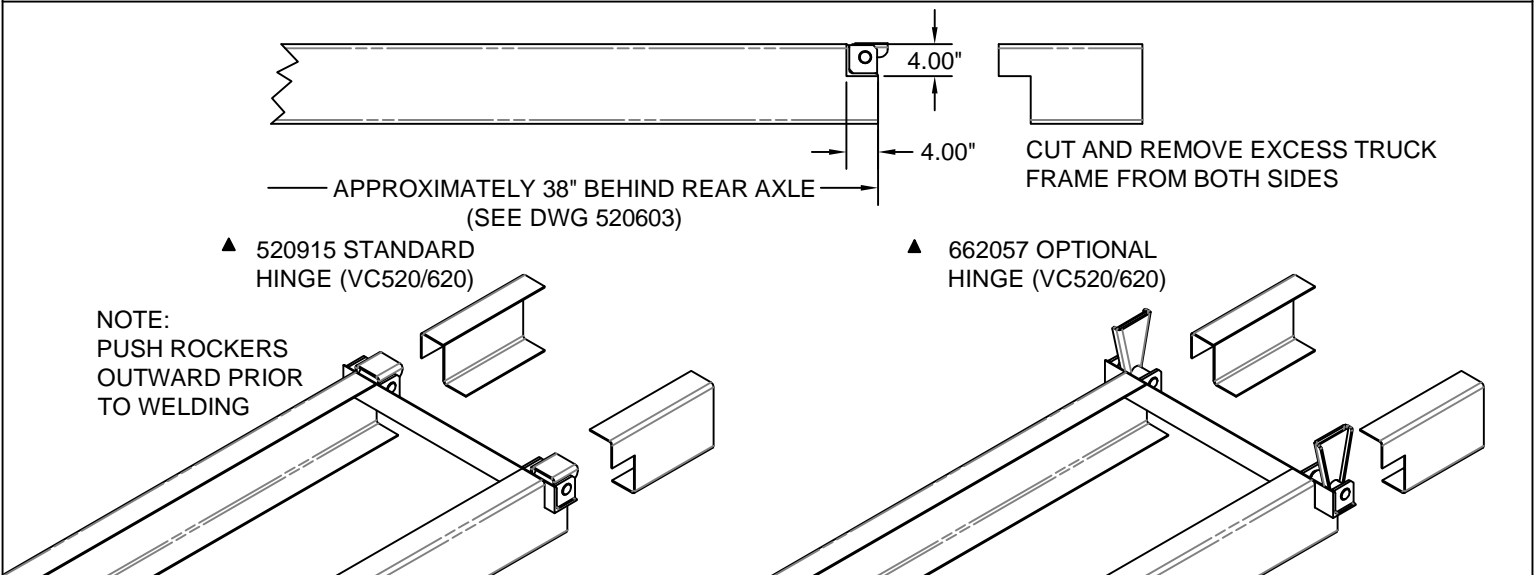

Figure 2 - Frame Modification and Rear Hinge Attachment

- D. Locate the hoist on the truck frame, making sure to center and square the hoist to the truck frame. The VC hoist is designed to rest on the truck frame. A section of the hoist extends below the truck frame level. Therefore, the hoist may have to be moved slightly forward or backwards to avoid frame crossmembers. The distance between the rear hinge assembly center and the center of the lower pivot is referred to as the "M Dimension". The table on Mounting Dimensions drawing 520603 or 620122 provide the dump angles associated with the "M Dimensions".

Note: Moving the hoist along the truck frame will affect the hoist's performance. A forward movement (towards the cab) decreases dump angle and increases capacity. A backwards movement increases dump angle and decreases capacity. Reference Capacity Chart drawings 520601 or 620103.



VENCO VENTURO INDUSTRIES LLC
CINCINNATI, OHIO

TITLE	DATE	SECTION
MOUNTING INSTRCTNS	12-07-15E	H200
VC520/620 (NON-SF)	SUPERSEDES 11-06-15D	520604

HOIST MOUNTING INST. - VC520/620 NON-SUBFRAME

- E. After the hoist is positioned, place the mounting angles (Figure 3) under the lower pivot angles and against the truck frame. Clamp securely in place. Drill through the frame and install the mounting angle with two [2] 1/2-13 x 1-1/2" Grade 8 hex head cap screws, lock washers, hex nuts, and four [4] flat washers (both sides).



C A U T I O N

- The hoist lower pivot assembly must sit flush on the truck frame. If rivet head interference is encountered, use a filler block or countersink clearance holes in the bottom of the pivot assembly. **DO NOT** weld hoist mounting angle to truck frames - this may void the truck warranty.

- F. Weld each end of the lower pivot angle to its mounting angle as shown in Figure 3. Note the welding symbols. Do not weld to the truck frame.

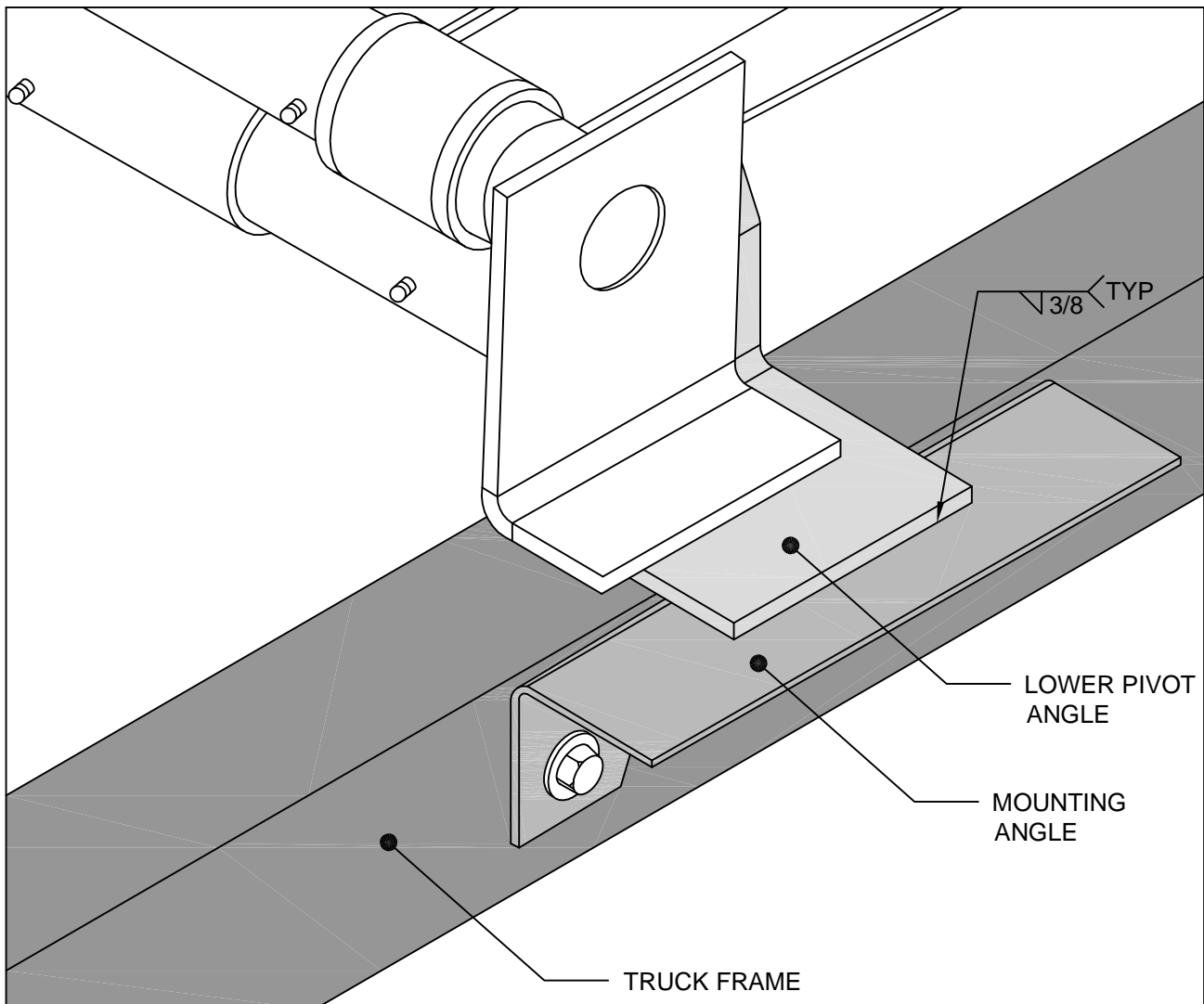

Figure 3. Mounting angle assembly.



VENCO VENTURO INDUSTRIES LLC
CINCINNATI, OHIO

TITLE
MOUNTING INSTRCTNS
VC520/620 (NON-SF)

DATE
10-22-15C
SUPERSEDES
03-17-14B

SECTION
H200
520605

HOIST MOUNTING INSTRUCTIONS (CONT.)

G. Install hydraulic hoses per the following instructions:

- ▲ 1. 7' (or 7'-10") hose(s) installation - Connect one end of the hose to the front pump port (low pressure). Connect the other end of the hose to the rod end of the hoist cylinder (Reference DWGs 416763 and 520621).
- ▲ 2. 5' hose(s) installation - Connect one end of the hose to the rear pump port (high pressure). Connect the other end of the hose to the base end of the hoist cylinder (Reference DWGs 416763 and 520621).

H. Position and secure the filler strips (liner or sleeper) to the truck frame.

The VC520 with sub-frame requires a minimum of 7-1/2" clearance above the truck frame.

The VC520 (non sub-frame) requires a minimum of 8" clearance above the truck frame.

NOTE: If the hoist needs to be mounted higher due to interference between the hoist knuckle and the truck frame, additional clearance above the truck frame will be required.

EXAMPLE (Non sub-frame model):

Assuming that a 8" clearance is required and 6" long beams are on the truck body, a liner of at least 2" net will be required to obtain the minimum clearance required to mount the hoist.

$6" + 2" = 8"$ minimum

I. Position the body longitudinals (long beams) onto the truck frame / sub-frame.

NOTE: At least 2" clearance between the cab and closest point on the truck body is required.

J.

a. STANDARD HINGE (520915)

With the body aligned with the truck frame, push the hinge rockers outward as far as possible. Ensure that the longitudinal rails are sitting flat on the rockers, weld the body longitudinals to rockers (DWG 520604 Figure 2). See installation DWG 662861 for more information regarding the mounting of the rear hinge rockers to the body.

b. OPTIONAL HINGE (662057)

Place the rear hinge brackets in the vertical position (DWG 520604 Figure 2). Weld and/or bolt the brackets to the longitudinals. If bolted, mark and drill each bracket four [4] places (17/32" holes) and secure the brackets to the longitudinals using eight [8] 1/2"-13 x 1-1/2" Grade 8 hex head cap screws, eight [8] 1/2" lock washers, and eight [8] 1/2"-13 hex nuts. See installation DWG 662861 for more information regarding the mounting of the rear hinge brackets to the body.

K. **Refer to DWG 520093 on the following page.** Make sure that the dump body longitudinals are resting flush on the top of the lifting angles. Weld the top of both lifting angles (the vertical 'leg') to the top flanges of the body longitudinals - a reinforcement plate may be required to fill the space between the lifting angles and body longitudinals. Weld all around the lifting angles, body longitudinals, and reinforcement plates (if applicable). **Be sure that your installation follows the method shown on the following page** (DWG 520093).



CAUTION



- Step "K" (above) is a critical installation procedure that must be carefully followed to ensure a successful hoist installation. Deviation from the suggested installation method may result in damage to the hoist.



VENCO VENTURO INDUSTRIES LLC
CINCINNATI, OHIO

TITLE
MOUNTING INSTRCTNS

DATE
07-31-17F

SECTION
H200

VC416-VC620 ▲

SUPERSEDES
01-12-16E

520609

IMPORTANT!

WHEN INSTALLING THE UPPER LIFTING ANGLES, THE GOAL IS TO COMPLETELY "BOX IN" THE LIFTING ANGLE, BODY LONG SILL SPACER, AND REINFORCEMENT PLATE - 100% WELD.

**SITUATION A:
LIFTING ANGLE FULLY
ENVELOPS BODY LONG SILL.**

▲ COLLAR SHOULD BE PROPERLY LOCATED AND STITCH WELDED TO PIVOT ROD TO LIMIT SIDE-TO-SIDE MOVEMENT OF SCISSORS (416-520 ONLY).

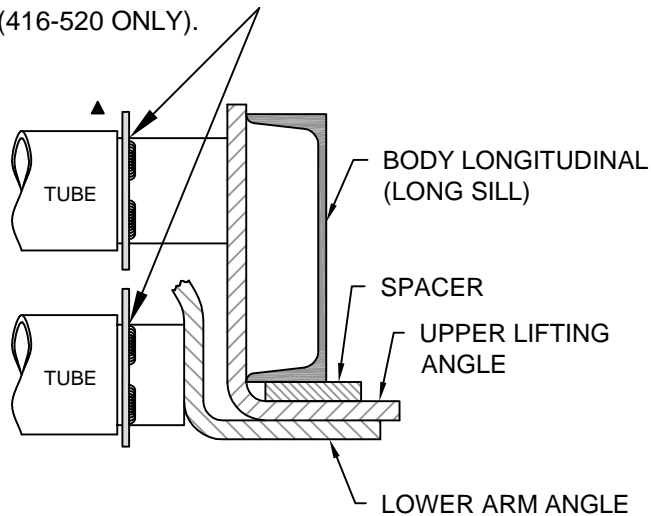

**SITUATION B:
LIFTING ANGLE DOES NOT
ENVELOP BODY LONG SILL AND
A REINFORCEMENT PLATE
IS REQUIRED.**

▲ COLLAR SHOULD BE PROPERLY LOCATED AND STITCH WELDED TO PIVOT ROD TO LIMIT SIDE-TO-SIDE MOVEMENT OF SCISSORS (416-520 ONLY).

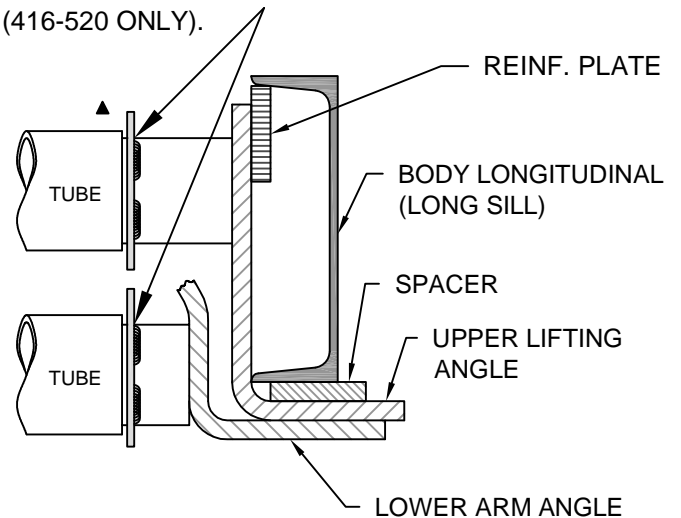

NOTE: THE SPACER AND REINFORCEMENT PLATE SHOULD BE THE SAME LENGTH AS THE LIFTING ARM. SEE 'L' DIMENSION BELOW.

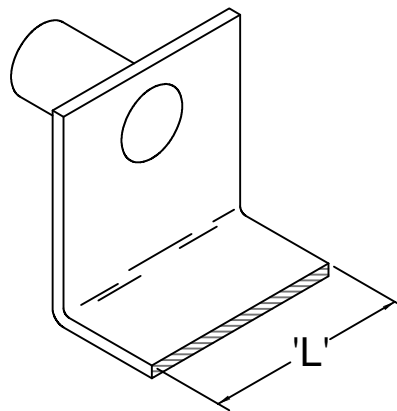

VENCO VENTURO INDUSTRIES LLC
CINCINNATI, OHIO

TITLE
INSTLL. INSTRUCTIONS

DATE
08-20-14E

SECTION
H200

VC416-6628, TRLR313-6628

SUPERSEDES
01-14-13D

520093

HINGE MNTG INST. VC416 - VC620 NON-SUBFRAME

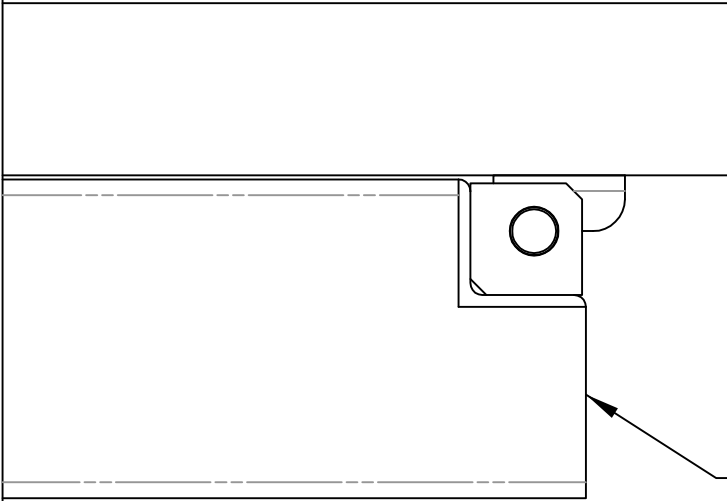

TRUCK FRAME
(CHASSIS)

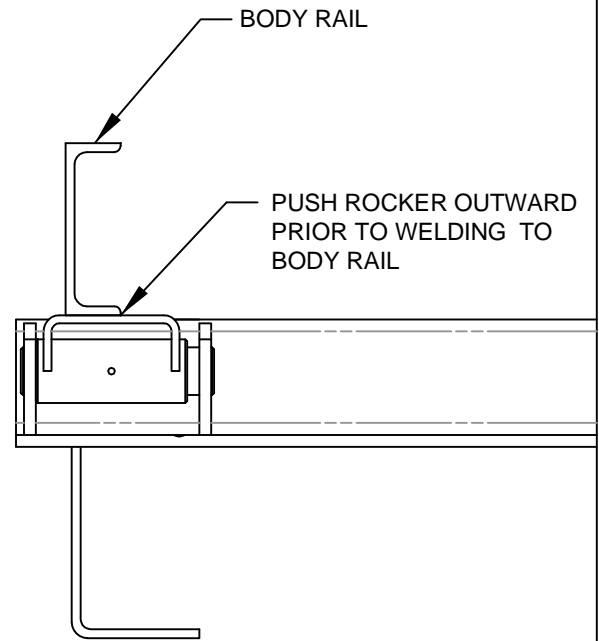

BODY RAIL

PUSH ROCKER OUTWARD
PRIOR TO WELDING TO
BODY RAIL

520915 HINGE
STANDARD → VC416-620

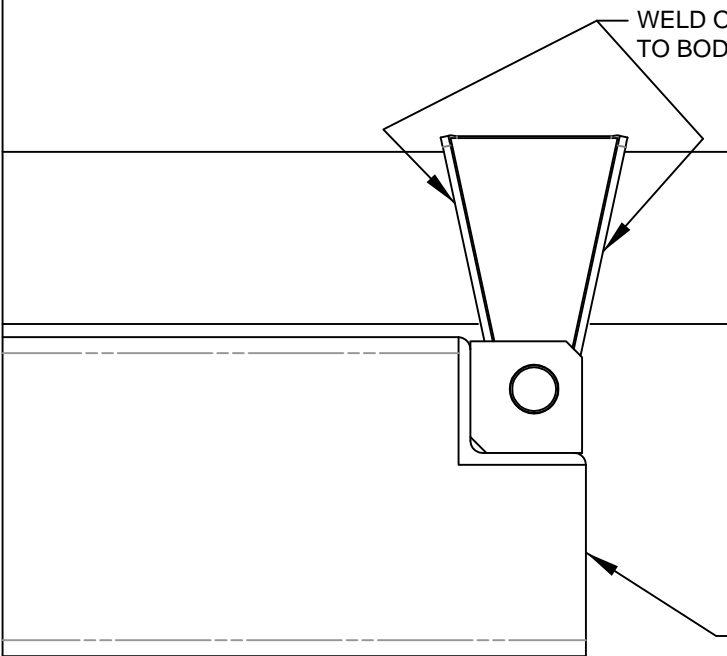

TRUCK FRAME
(CHASSIS)

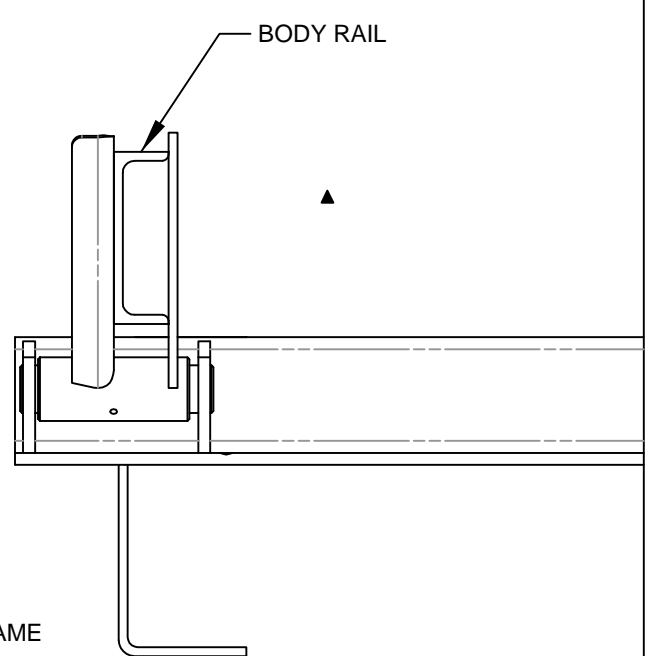

BODY RAIL

▲ 662057 HINGE
OPTIONAL → VC416-620



VENCO VENTURO INDUSTRIES LLC
CINCINNATI, OHIO

TITLE	DATE	SECTION
HINGE TO BED MNTG	12-07-15E	H200
VC416 - VC620 (NON-SF)	SUPERSEDES 10-23-15D	662861

DATE
12-07-15E

SECTION
H200

SUPERSEDES
10-23-15D

662861

HOIST MOUNTING INST. - VC416-620 UNIVERSAL S/F

Refer to drawing 416266 (VC416), 516203 (VC516), 520602 (VC520), or 620104 (VC620) (preceding pages).

- A. Position hoist into the front half of the sub-frame by inserting the two lower pivot angles into the lower pivot tube on the scissors, and then positioning that assembly inside front half of sub-frame. The two holes on each lower pivot angle should match up with a set of holes on sub-frame mounting brace. The front hole set on sub-frame corresponds to a dump angle of 45°, and the rear to 50°. See DWG. 520938 for sub-frame features.

NOTE: Position scissor support cross-member for 50° or 45° dump angle accordingly.

- B. Fasten lower pivot angles to sub-frame using two [2] 1/2" x 1 1/2" hex head cap screws, lock washers, nuts, and four [4] flat washers (both sides). See DWG. 520608 Figure 4a.
- C. Position hoist with sub-frame front section onto truck frame.

NOTE: Refer to DWG. 520938 universal sub-frame features (section 100) for positioning the hydraulic power unit cross-member.

- D. Place rear section of sub-frame onto truck frame.

NOTE: Do not allow sub-frame to extend beyond truck frame. Sub-frame and hinge must be supported by truck frame.

- E. Trim off any truck frame that extends beyond the rear hinge.
- F. Fasten rear half of sub-frame to truck by welding the two shear plates (REF. P/N 520932) to rear hinge angle of sub-frame, drilling corresponding holes through truck frame, and using two [2] 1/2" x 1 1/2" hex head cap screws, lock washers, nuts, and four [4] flat washers (both sides).
- G. Install the sub-frame extensions (if required) using the provided hardware.
- H. After attaching the two halves, place mounting angles under the lower pivot angles and against truck frame. Clamp securely in place. Drill through frame, and install mounting angle with two [2] 1/2" x 1 1/2" hex head cap screws, lock washers, nuts, and four [4] flat washers (both sides). See figure 5.

NOTE: Do not weld mounting angles to truck frame. This may void the truck's warranty.

- I. Weld each end of lower pivot angle to its mounting angle as shown on DWG. 520608, figure 4b. Note the welding symbols. Do not weld to truck frame.



VENCO VENTURO INDUSTRIES LLC
CINCINNATI, OHIO

TITLE	DATE	SECTION
MOUNTING INSTRCTNS	11-05-15C	H200
VC416-620 UNIVSL S/F	SUPERSEDES 08-21-15B	520941

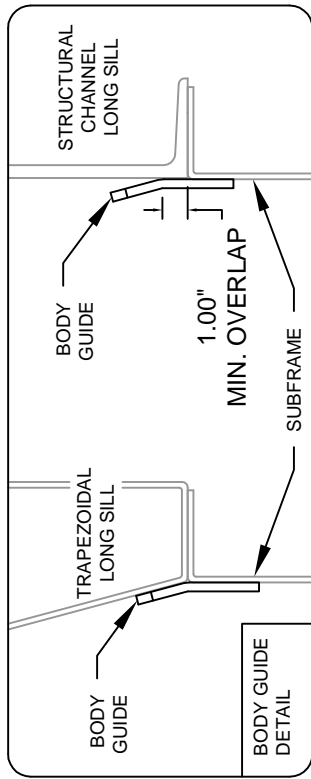

CROSSMEMBER MAY BE ROTATED 90 DEGREES TO PROVIDE ADDITIONAL CLEARANCE BETWEEN HOIST AND CHASSIS COMPONENTS.

BODY GUIDES AND SHEAR PLATES ARE SHIPPED LOOSE. POSITION AND WELD TO ACCOMMODATE DUMP BODY LONG SILLS; C CHANNEL OR TRAPEZOIDAL

SUB-FRAME EXTENSIONS REQUIRE TWO RECTANGULAR SHEAR PLATES LOCATED AS INDICATED

POWER UNIT BRACKET TO BE INSTALLED ON FRONT OF SUB FRAME OR SUBFRAME EXTENSIONS AS SHOWN.

NOTE: POWER UNIT BRACKET ORIENTATION MAY BE REVERSED TO PROVIDE CLEARANCE FOR POWER UNIT.

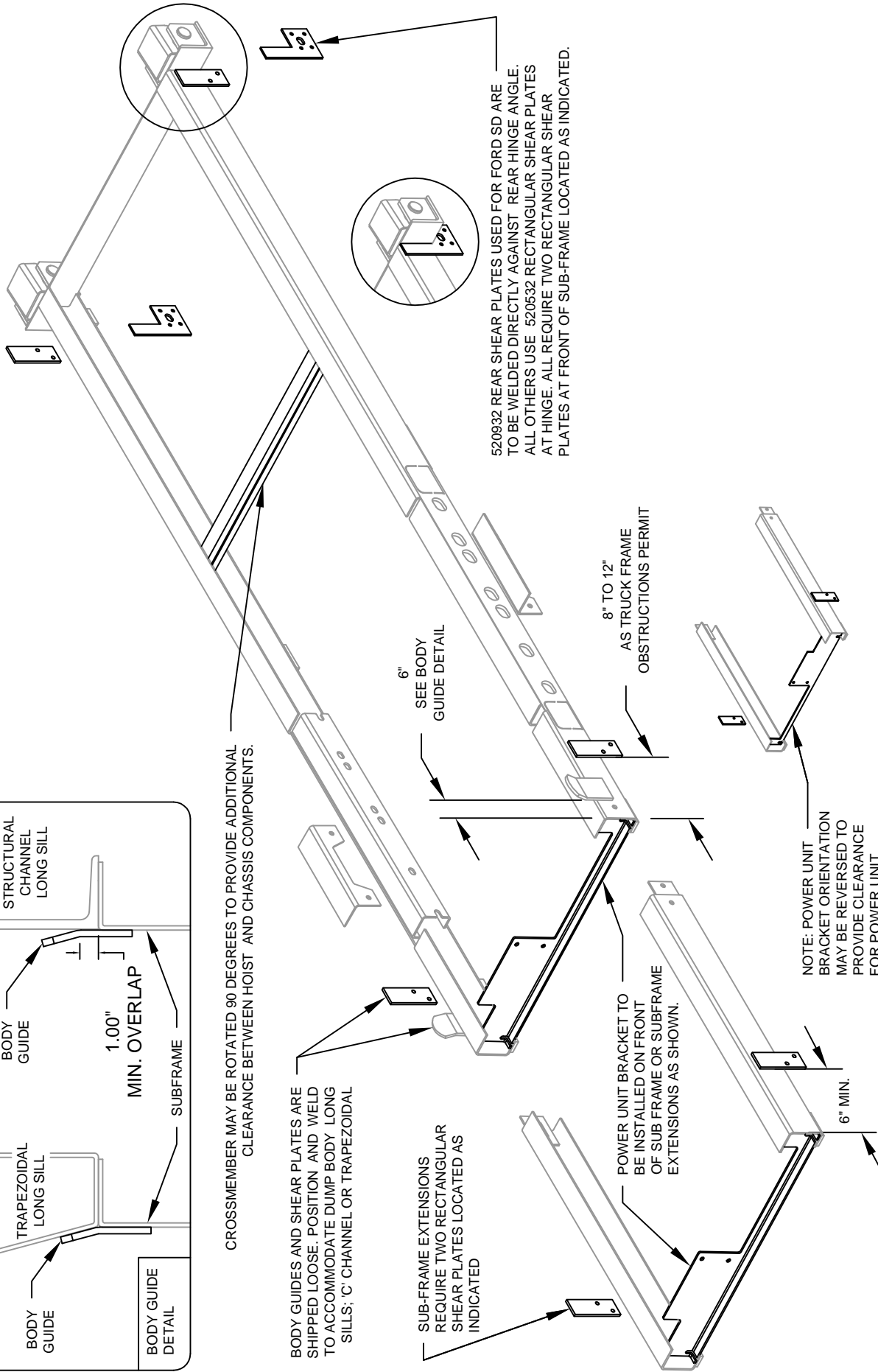

520932 REAR SHEAR PLATES USED FOR FORD SD ARE TO BE WELDED DIRECTLY AGAINST REAR HINGE ANGLE. ALL OTHERS USE 520532 RECTANGULAR SHEAR PLATES AT HINGE. ALL REQUIRE TWO RECTANGULAR SHEAR PLATES AT FRONT OF SUB-FRAME LOCATED AS INDICATED.

REPLACEMENT PARTS LIST REF 520940

 VENCO [®] VENCO VENTURO INDUSTRIES LLC CINCINNATI, OHIO	TITLE	SHEAR PLATE LOCATION DRAWING	
	SECTION	DATE	10-26-15A
	SUPERSEDES	06-23-15	
		SECTION	H200
			552009

HOIST MNTG INST. VC416-6628 W/ SUB-FRAME

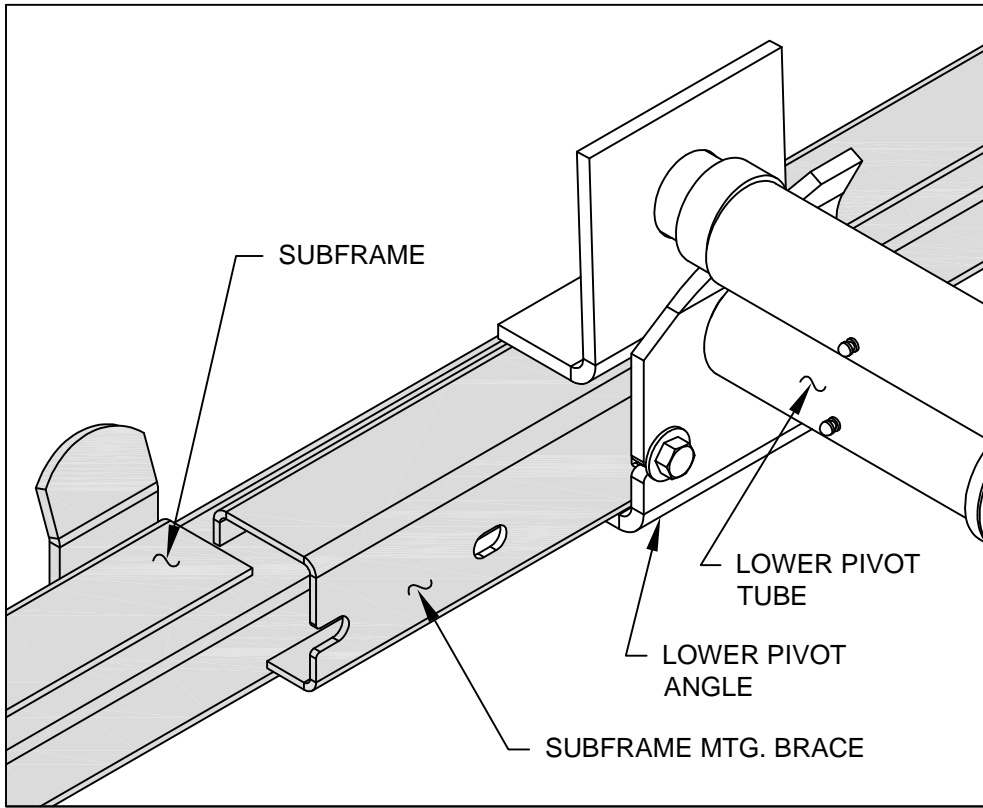

FIGURE 4a

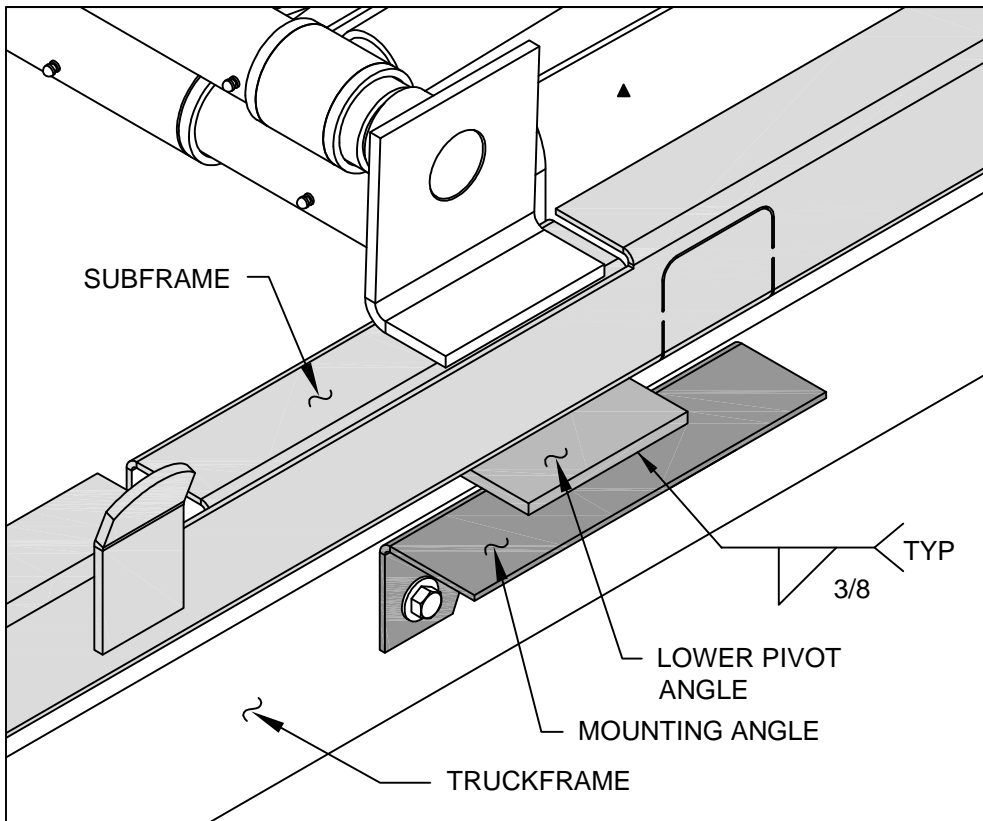

FIGURE 4b



VENCO VENTURO INDUSTRIES LLC
CINCINNATI, OHIO

TITLE
MNTNG ILLUSTRATION
VC416-620

DATE
11-05-15D
SUPERSEDES
03-17-14C

SECTION
H200
520608

ATTACHING 620129 CABLE TO 620131 / 132 HANDLE

- Step 1. Remove lowest screw & nut.
- Step 2. Depress red button on top of handle. Push handle forward and hold.
- Step 3. While holding handle, thread "barrel nut" into threaded hole in bottom and tighten.
- Step 4. Release handle. Handle should return to center position.
- Step 5. Replace screw & nut, making sure that radius on cable end is aligned with screw hole. After tightening screw, move handle forward and backward to make sure cable end is secure in console.

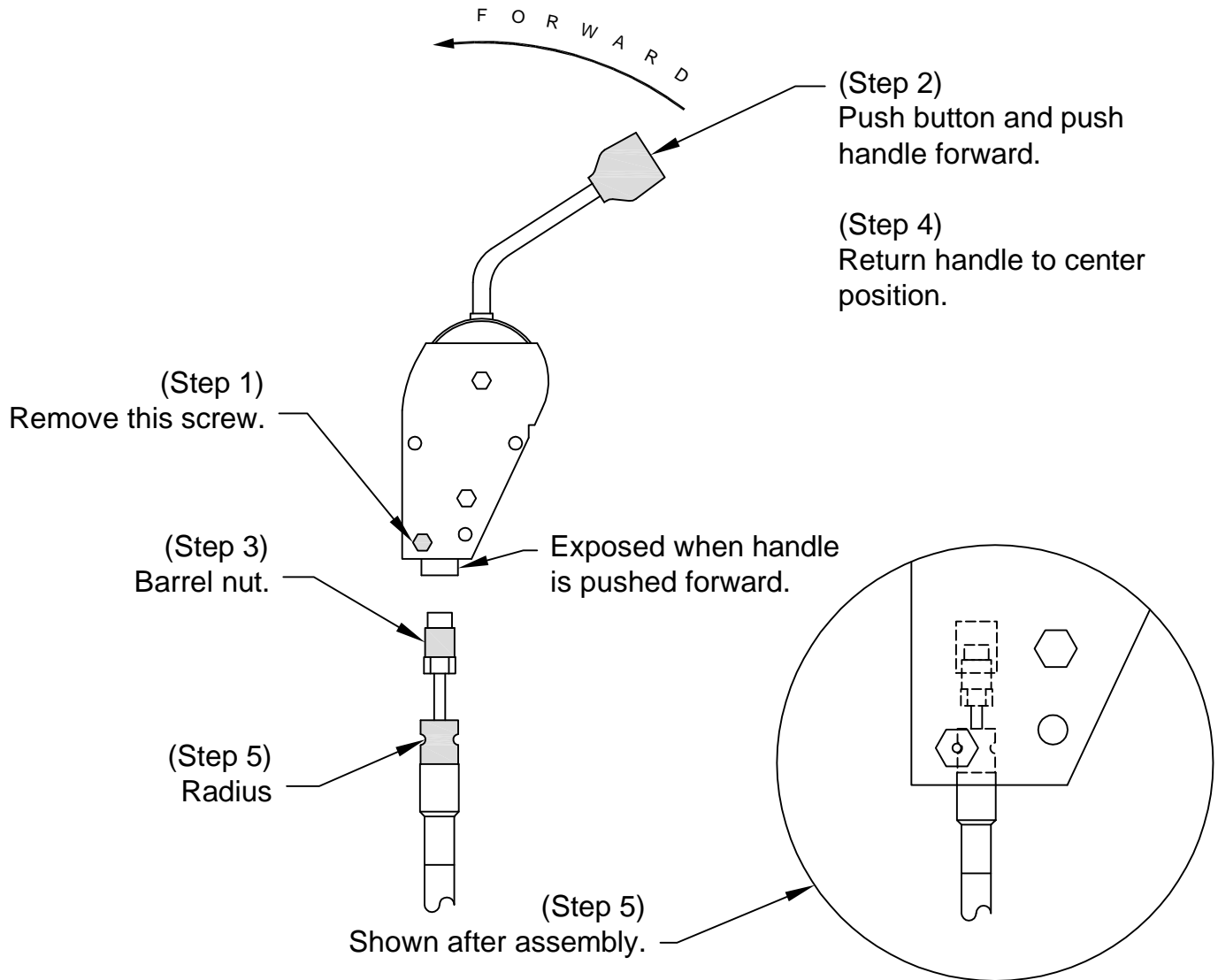

VENCO VENTURO INDUSTRIES LLC
CINCINNATI, OHIO

TITLE
CABLE / HANDLE ASSY
PTO PUMP CABLE

DATE
11-05-15B
SUPERSEDES
03-17-14A

SECTION
-
620246

PTO PUMP CABLE INSTALLATION

1. Thread 0.750-16 UNF jam nut entire length of threaded hub and onto cable.
2. Place flange on sleeve and turn flange / sleeve assembly entire length of threaded hub and onto cable.
3. Threade 0.250-28 UNF jam nut onto threaded rod until it bottoms.
4. Thread terminal eye onto threaded rod and bottom against jam nut, turn to align with spool slot and secure jam nut against terminal eye.
5. Slide terminal eye into slot in spool and align holes. Insert connecting pin and secure with cotter pin (if applicable).
6. With cable attached to valve and input device, thread the flange / sleeve assembly onto the threaded hub until it is flush with the valve face. When turning the flange / sleeve assembly, make sure the input device remains in the neutral position.
7. Tighten the 0.750-16 UNF jam nut against the sleeve to lock in position.
8. Bring flange into position and bolt assembly to valve housing using two [2] socket head cap screws and two [2] split lock washers under head and two [2] flat washers under lockwashers. Tighten screws sufficiently to flatten lock washers or secure flange (see CAUTION).

CAUTION

- Excessive torque or over-tightening will distort flange.

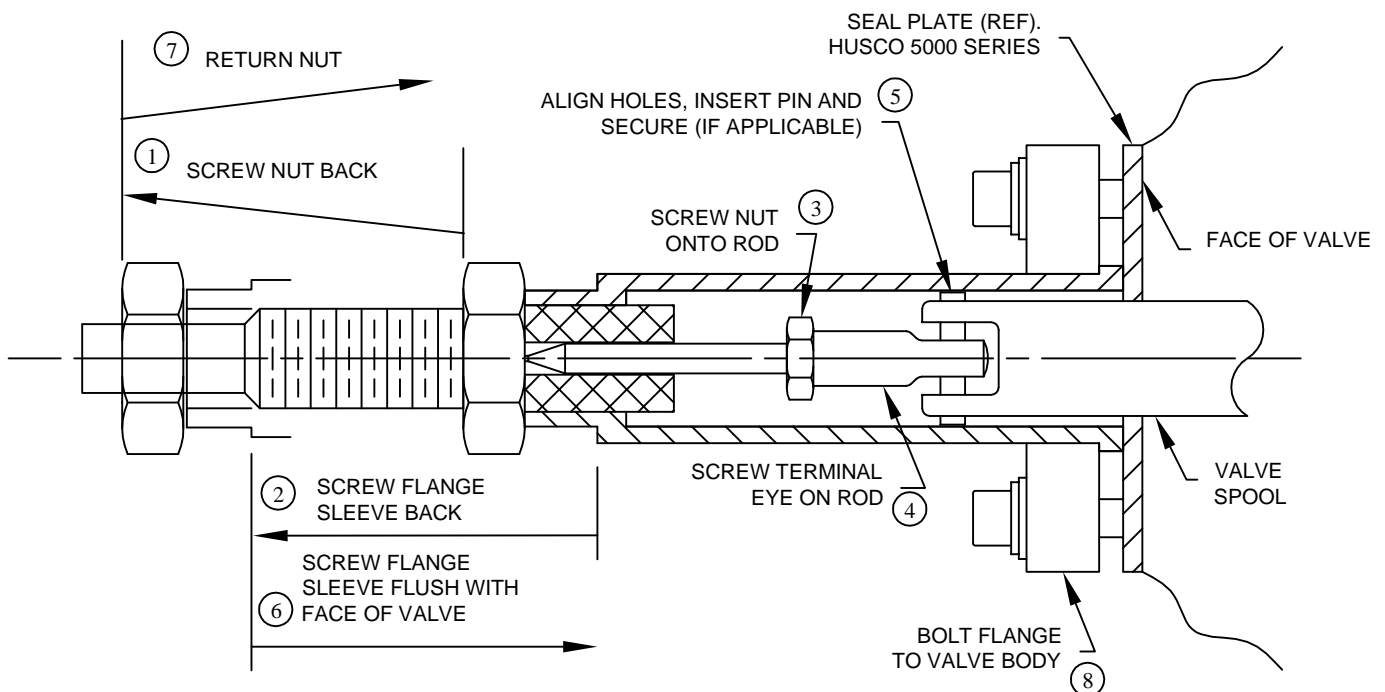

VENCO VENTURO INDUSTRIES LLC
CINCINNATI, OHIO

TITLE
PTO PUMP CABLE INSTL

VC416-6628

DATE
11-05-15B

SUPERSEDES
03-17-14A

SECTION
-

416755

DIRECTIONAL PUMP CONFIGURATION FOR VC416-620

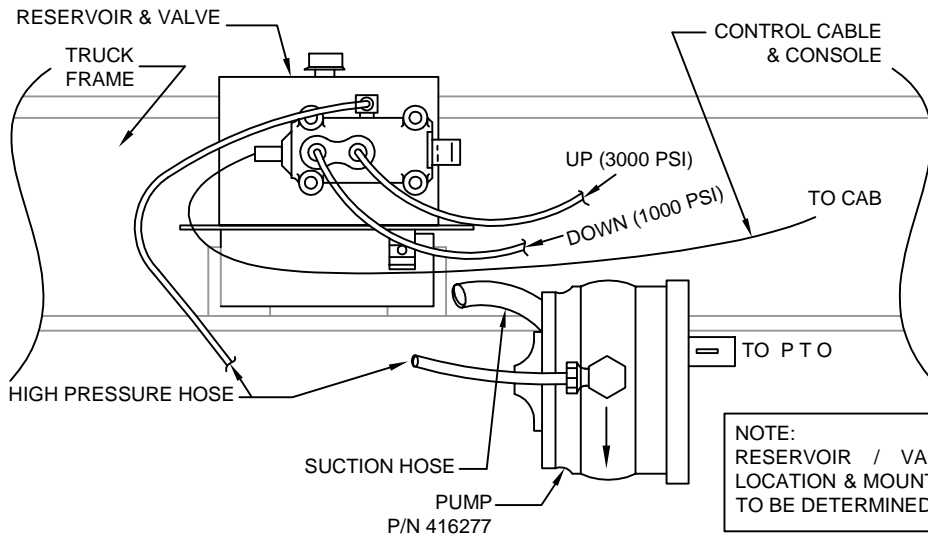

BI-DIRECTIONAL PUMP CONFIGURATION FOR VC628 & UP

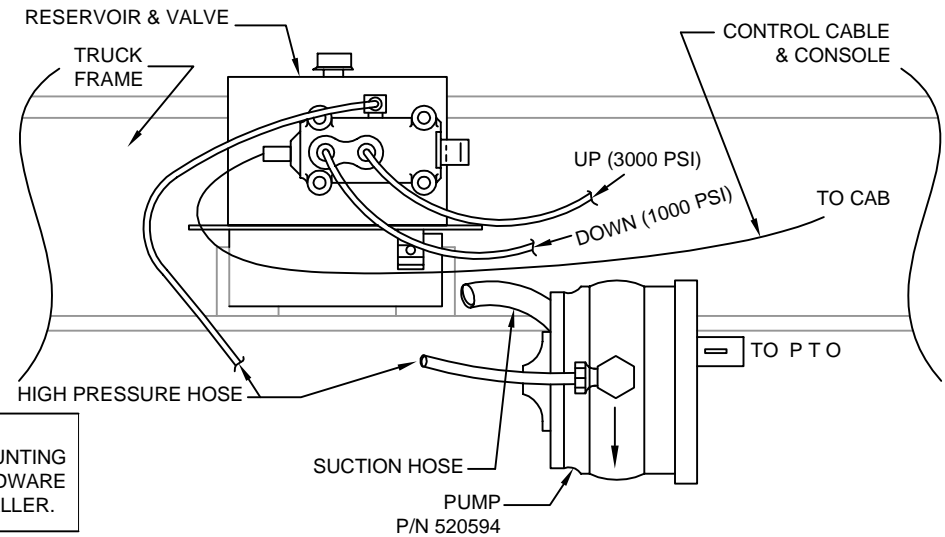

NOTE:
RESERVOIR / VALVE MOUNTING
LOCATION & MOUNTING HARDWARE
TO BE DETERMINED BY INSTALLER.

NOTE: ARROW ON PUMP HOUSING INDICATED ROTATION DIRECTION.
FAILURE TO MATCH PTO ROTATION WITH PUMP ROTATION **WILL**
RESULT IN PUMP FAILURE.

NOTE: FOR BI-ROTATIONAL PUMP MOUNTING AND HOSE CONNECTION
INFORMATION, SEE DWG 416812 (IF APPLICABLE).

Model	VC416	VC516	VC520	VC620	VC628	VC5520	VC6620	VC6628
Control Cable & Console				620125 - Curved	620124 - Straight			
Cylinder Up Hose	416044		416045			520574		
Cylinder Down Hose				416045		628041	(2) 416045	
High Pressure Hose (pump to valve)	416045 (7' LG, 3/8 HOSE)			620909 (10' LG, 3/8 HOSE) FOR VC620 NON-SF		620909 (10' LG, 3/8 HOSE)		
				416045 (7' LG, 3/8 HOSE) FOR VC620 SF				
Suction Hose (reservoir to pump)	416079 (7' LG, 1.00" I.D.)			620910 (10' LG, 1.00" I.D.) FOR VC620 NON-SF		520088F (10' LG, 1-1/4" I.D.)		
				416079 (7' LG, 1.00" I.D.) FOR VC620 SF				
Pump/Valve/Tank	620011 (9 QUART)			662077 (21 QUART)				
Pump (Only)	416277 (5gpm)			520594 (10gpm)				



VENCO VENTURO INDUSTRIES LLC
CINCINNATI, OHIO

TITLE
SPLIT PUMP

VC416-6628

DATE
03-16-22E

SUPERSEDES
08-01-17D

SECTION
H200

416763

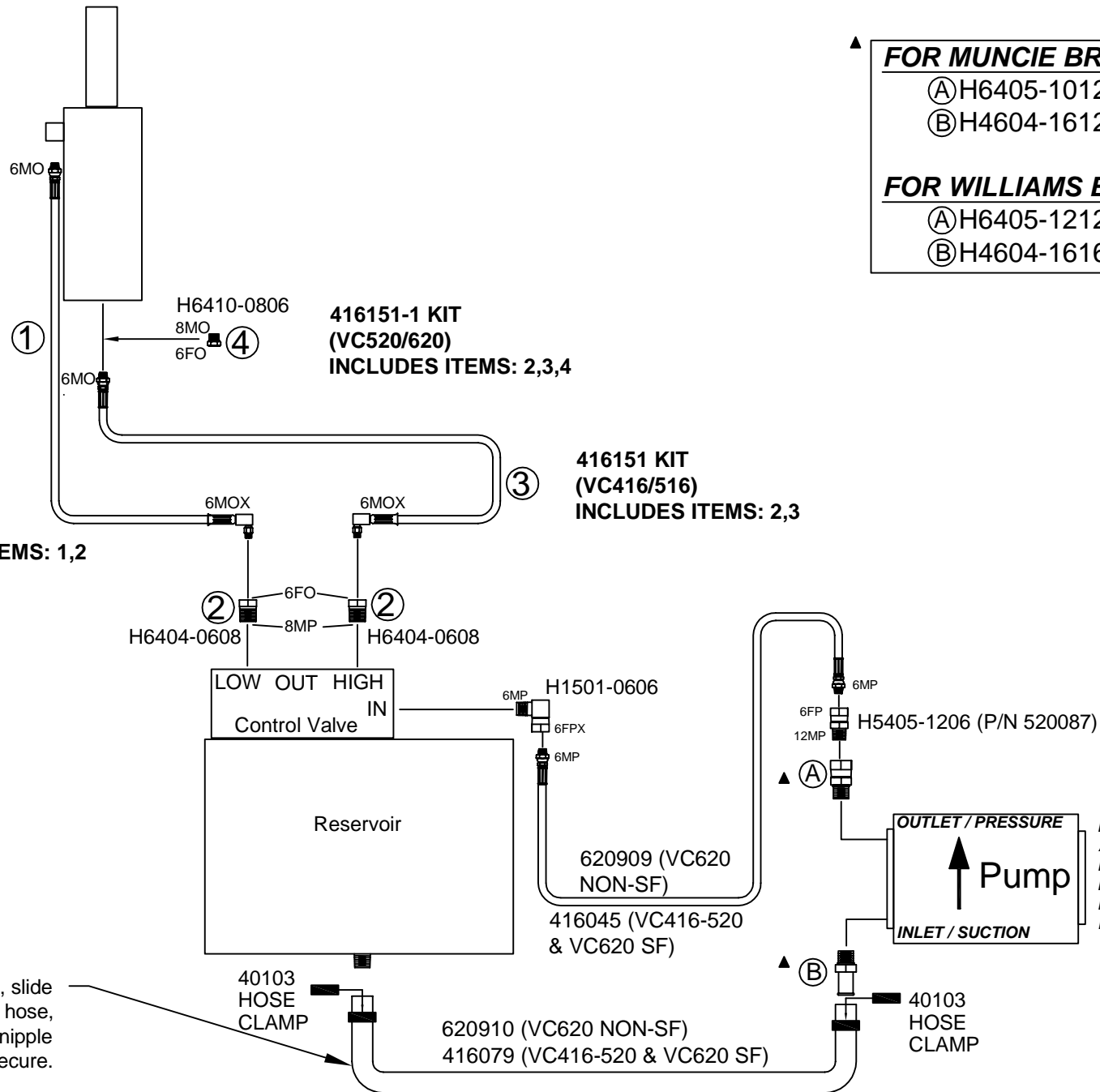

FOR MUNCIE BRAND PUMP (416277):

- (A) H6405-1012 (P/N 416861)
- (B) H4604-1612 (P/N 416862)

FOR WILLIAMS BRAND PUMP (520092):

- (A) H6405-1212 (P/N 416133)
- (B) H4604-1616 (P/N 416095)

NOTE: On both ends, slide hose clamp over hose, then fit hose over nipple and use clamp to secure.



VENCO VENTURO INDUSTRIES LLC
CINCINNATI, OHIO

TITLE
SPDG HOSE CONNECTION DIAGRAM

VC416-620

DATE
02-17-17F

SUPERSEDES
02-15-17E

SECTION
-

520621

Williams[®] Machine & Tool Co.

MANUFACTURERS OF HYDRAULIC PISTON PUMPS



CAUTION



- The gear pump you have purchased is a single rotation Gear Pump. Installation of this Gear Pump into a system that does not match the rotation of the Gear Pump may result in personal injury and/or property damage.

The Gear Pump you have purchased is a single rotation Gear Pump. The direction of rotation can be found by using the Williams Machine and Tool Co.'s Model Number. Directly following the Model Number are the letters CCW or CW. These letters indicate the direction of rotation for the Gear Pump. CCW indicates a counter-clockwise rotation. CW indicates a clockwise rotation. Pump shaft rotation is determined by viewing pump from the shaft end.

Example: GP1538 CCW. The CCW indicates a counter-clockwise rotation.

To verify the direction of rotation of your Gear Pump, perform the following steps:

- 1.) Locate the Part Number on the Gear Pump. The Part Number, Serial Number, and date code are located on the rear of the Gear Pump.
- 2.) Part Numbers ending in an even number are clockwise rotation (CW). Part Numbers ending in an odd number are counter-clockwise rotation (CCW).

Example: 1830201. The last number is 1 (an odd number). This indicates a counter-clockwise rotation (CCW).

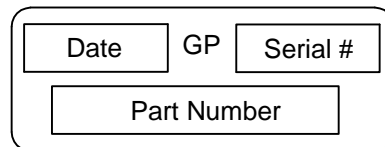

The following chart specifies torque requirements for the SAE O' ring plugs installed into the side or rear ports of the Gear Pump. Any combination of inlet and outlet ports may be used, ie., inlet large rear port. outlet small side port; inlet large side and outlet small rear ports; or both side ports or both rear ports. One inlet and one outlet part must be plugged for proper Gear Pump operation.

PORT SIZE (SAE)	TORQUE (FT. LBS)
3/4 - 16	15 - 20
7/8 - 14	20 - 25
1 - 1/16 - 12	30 - 35
1 - 5/16 - 12	45 - 50
1 - 5/8 - 12	65 - 70



VENCO VENTURO INDUSTRIES LLC
CINCINNATI, OHIO

TITLE

WILLIAMS PTO WARNING

DATE

11-05-15D

SECTION

H200

SUPERSEDES

03-17-14C

416287

HPU GROUNDING CABLE INSTALLATION

HYDRAULIC POWER UNIT (HPU) GROUNDING CABLE INSTALLATION

STEP 1

Locate the 5/16-18 tapped hole in the aluminum pump housing and attach one end of the black #4 Gage battery cable with the 5/16" hex head cap screw and Lock Washer.



C A U T I O N

- Prior to drilling the 9/32" hole in step 2, inspect the area on both sides of the chassis rail to ensure that you will NOT drill into other components - i.e. brake lines, etc. Then, drill hole as close to the center of the chassis rail as possible.

STEP 2

Drill a 9/32" hole in the truck frame.

STEP 3

Remove any undercoating around the drilled hole for best connection to the truck frame - clean surface to bare metal.

STEP 4

Attach the other end of the black #4 Gage battery cable with the 5/16" hex washer-head self-tapping fastener to the truck frame.

NOTE: To prevent corrosion, both fasteners should be coated with dielectric grease (NOT provided in kit).

NOTE: Using the Ground Strap Kit (P/N 6474) and following the mounting instructions on page 6368 in your Hoist Owner's Manual will provide a solid ground.



VENCO VENTURO INDUSTRIES LLC
CINCINNATI, OHIO

TITLE

GROUND CABLE INSTLLTN

DATE

10-09-15A

SECTION

-

HOIST HYD. POWER UNITS

SUPERSEDES

09-25-09

416640

ELECTRICAL CONNECTIONS - HYDRAULIC POWER UNITS

+12 Volt Power Connection:

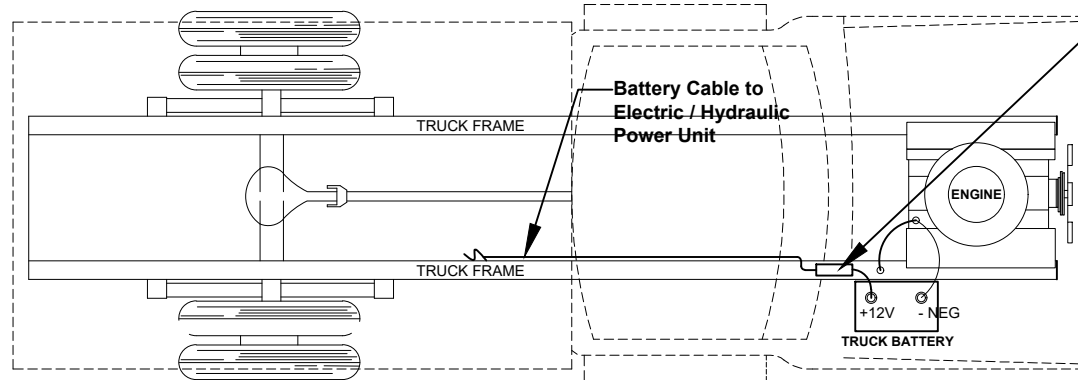

****IMPORTANT****

Locate the circuit breaker as close as practical to the battery for best protection of the battery cable servicing the electric / hydraulic power unit.

****NOTE****

Amp-draw of the electric / hydraulic power unit can be as high as **230amps** under normal conditions. The amp rating of the circuit breaker should be sized appropriately.

Grounding: Hydraulic power units WILL run with a poor ground connection, BUT the service life of the motor and control valve coils WILL be greatly reduced unless a proper ground connection is made - see illustrations below.

Non Sub-frame Grounding

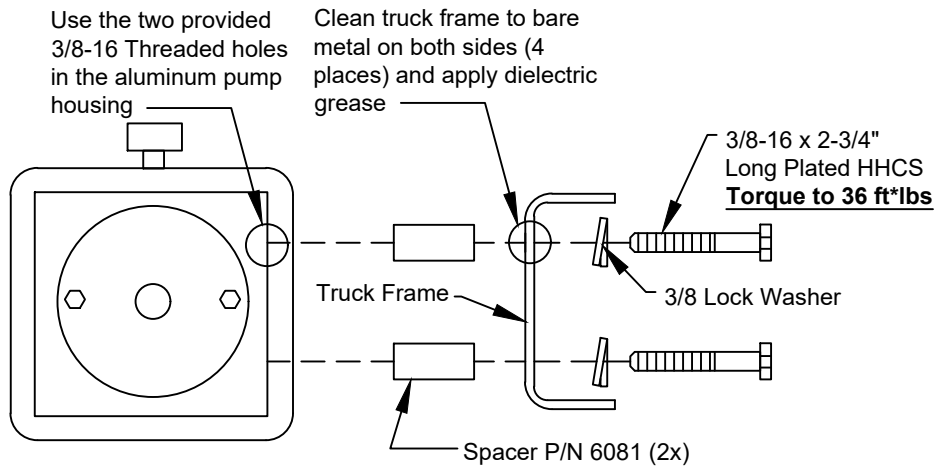

DO NOT APPLY THREAD LOCK LIQUIDS TO BOLT THREADS, AS THEY WILL INSULATE THE BOLTS FROM THE ALUMINUM PUMP HOUSING.

Sub-frame Grounding

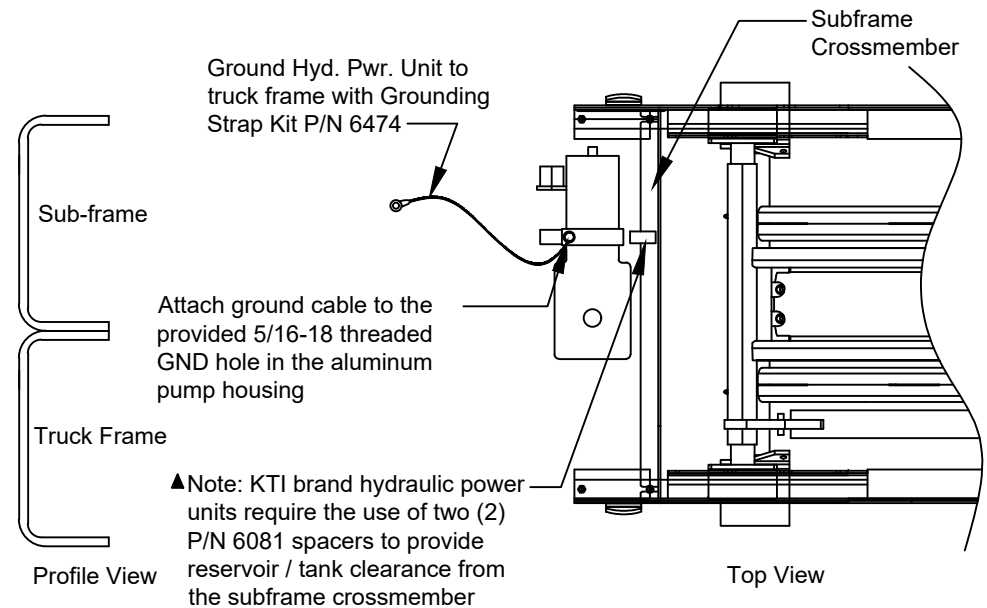

VENCO VENTURO INDUSTRIES LLC
CINCINNATI, OHIO

TITLE

ELECTRICAL CONNECTIONS - HYD PWR UNITS

DATE

01-30-24E

SECTION

-

ALL ELECTRIC HOIST APPLICATIONS

SUPERSEDES

09-23-20D

6368

40058M / MHD WITH MONARCH PUSH BUTTON CONTROL

GROUNDING STRAP ASSY P/N 6474.

TRUCK FRAME

3/8-16 HEX BOLT

SPACER P/N 6081

NOTE: BE SURE TO FOLLOW THE "PROPER GROUNDING OF HYDRAULIC POWER UNITS", DRAWING # 6368, IN THIS MANUAL.

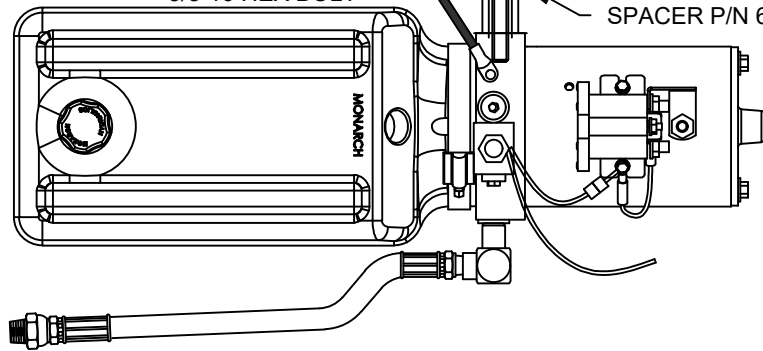

TOP VIEW

▲ **SUBFRAME MOUNTING**

Note that KTI brand hydraulic power units require the use of two (2) P/N 6081 spacers to provide reservoir / tank clearance from the subframe crossmember

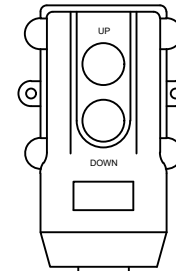

BLACK - HOT LEAD
WHITE - RAISE HOIST

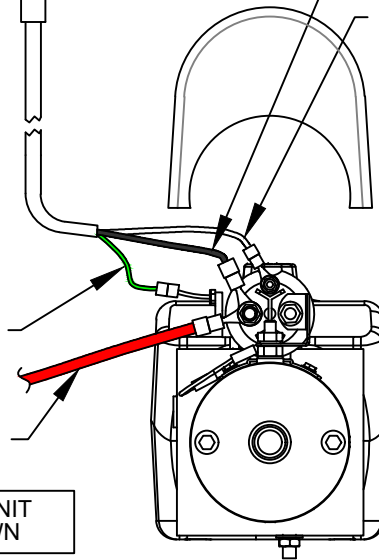

GREEN - LOWER HOIST
CONNECT TO
VALVE SOLENOID

+ BATTERY CABLE

SINGLE ACTING POWER UNIT
-POWER UP/GRAVITY DOWN

NOTE: BE SURE POWER UNIT HAS GROUND TO TRUCK FRAME.

SEE DRAWING 416308
FOR PARTS

BREATHER/FILL - REF

PRESSURE HOSE - CONNECT
TO BASE END OF HYDRAULIC
CYLINDER

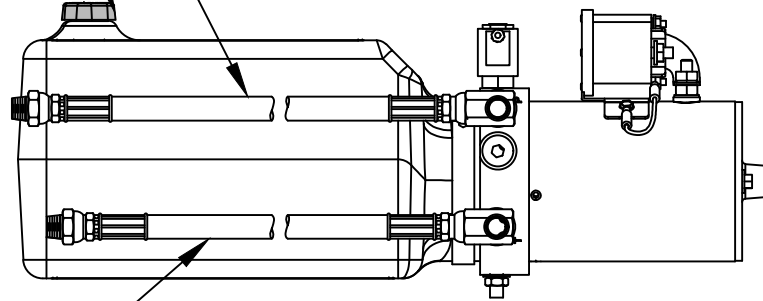

RETURN HOSE
- CONNECT TO ROD END
OF HYDRAULIC CYLINDER

SIDE VIEW



VENCO VENTURO INDUSTRIES LLC
CINCINNATI, OHIO

TITLE

40058M / 40058MHD POWER UNIT

VC416-628

DATE

01-30-24H

SUPERSEDES

12-09-15G

SECTION

H200

416809

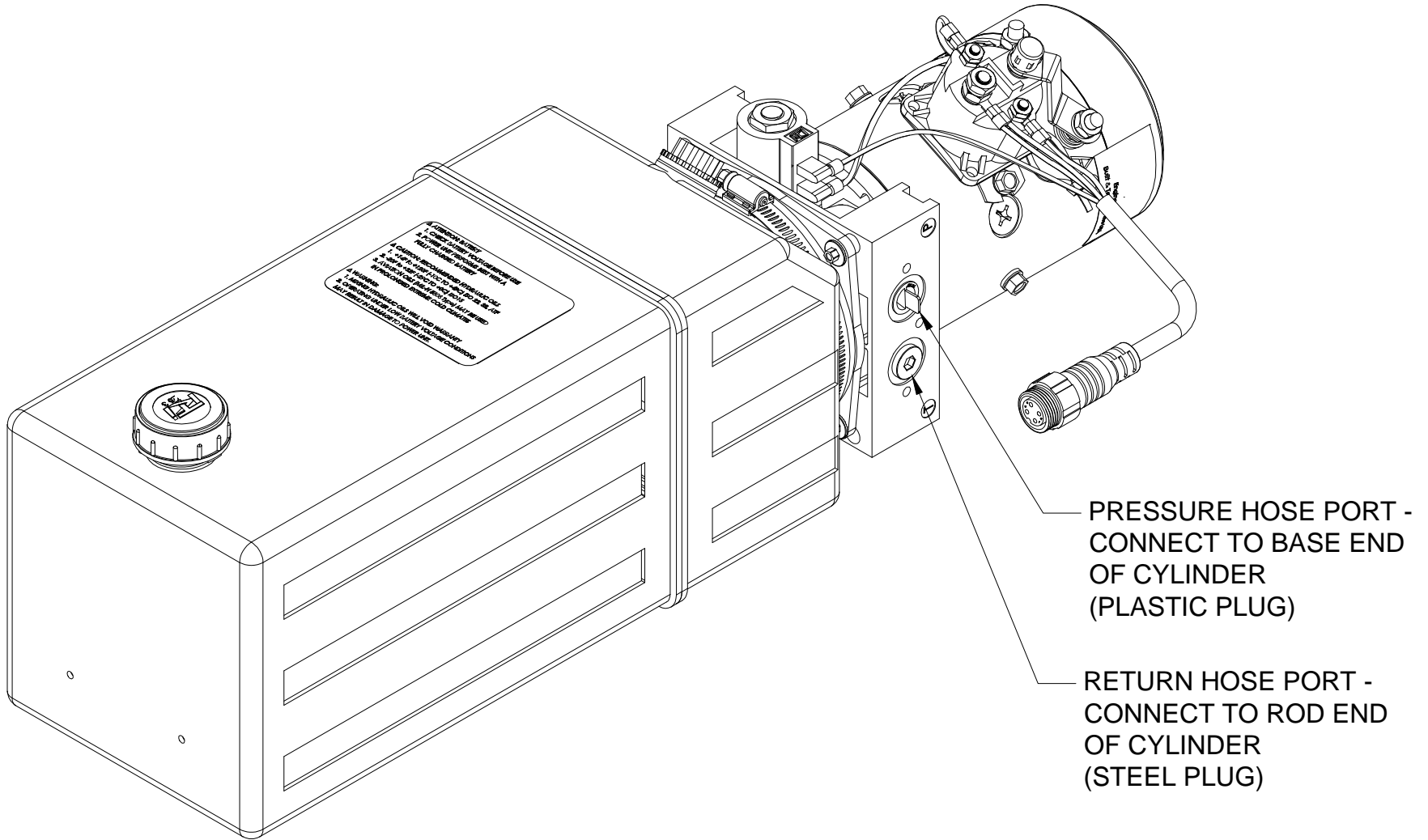

VENCO VENTURO INDUSTRIES LLC
CINCINNATI, OHIO

TITLE
HYD PORT LOCATIONS - KTI 40058
VC ES HOISTS

DATE
01-20-25
SUPERSEDES
-

SECTION
H200
416869

416081M WITH MONARCH PUSH BUTTON CONTROL

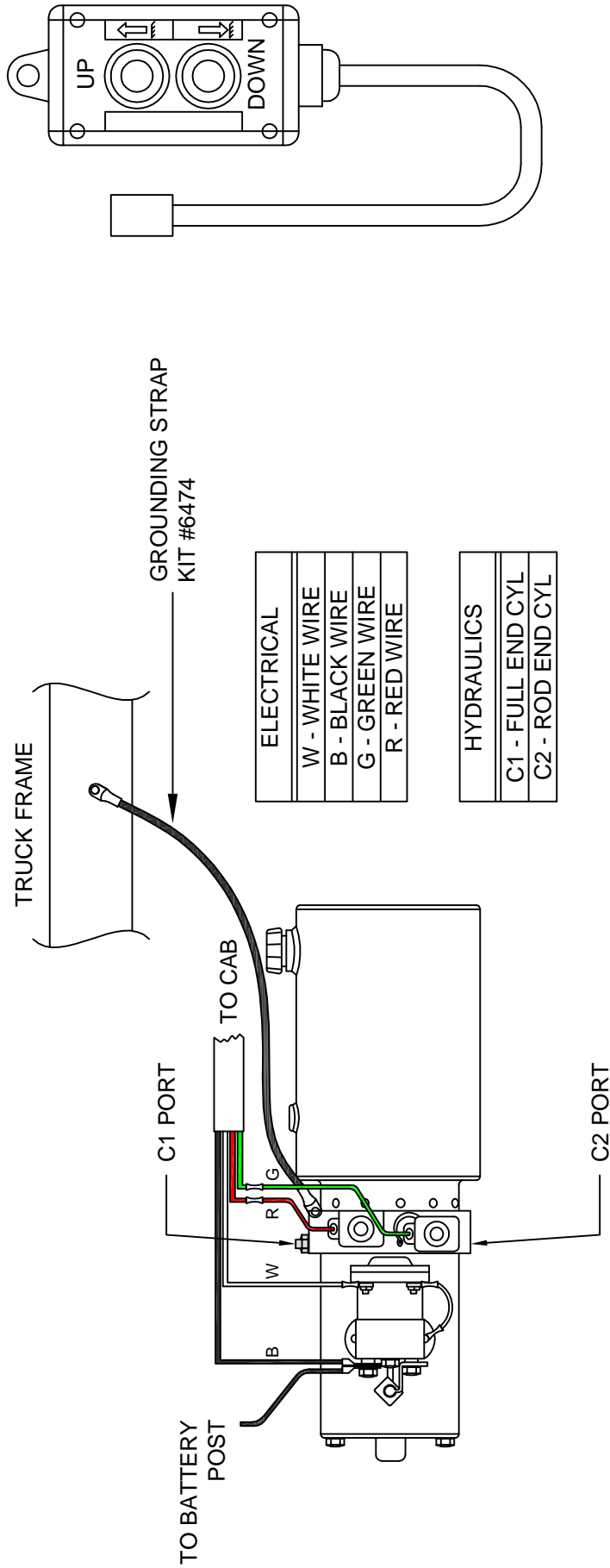

NOTE: ENERGIZING 'G' COIL SENDS FLOW TO 'C1' PORT (HOIST UP)
ENERGIZING 'R' COIL SENDS FLOW TO 'C2' PORT (HOIST DOWN)

 <p>VENCO VENTURO INDUSTRIES LLC CINCINNATI, OHIO</p>	TITLE	416081M ED POWER UNIT	DATE	12-08-15J	SECTION	-
		VC416-628 ▲	SUPERSEDES	10-09-15H		416307

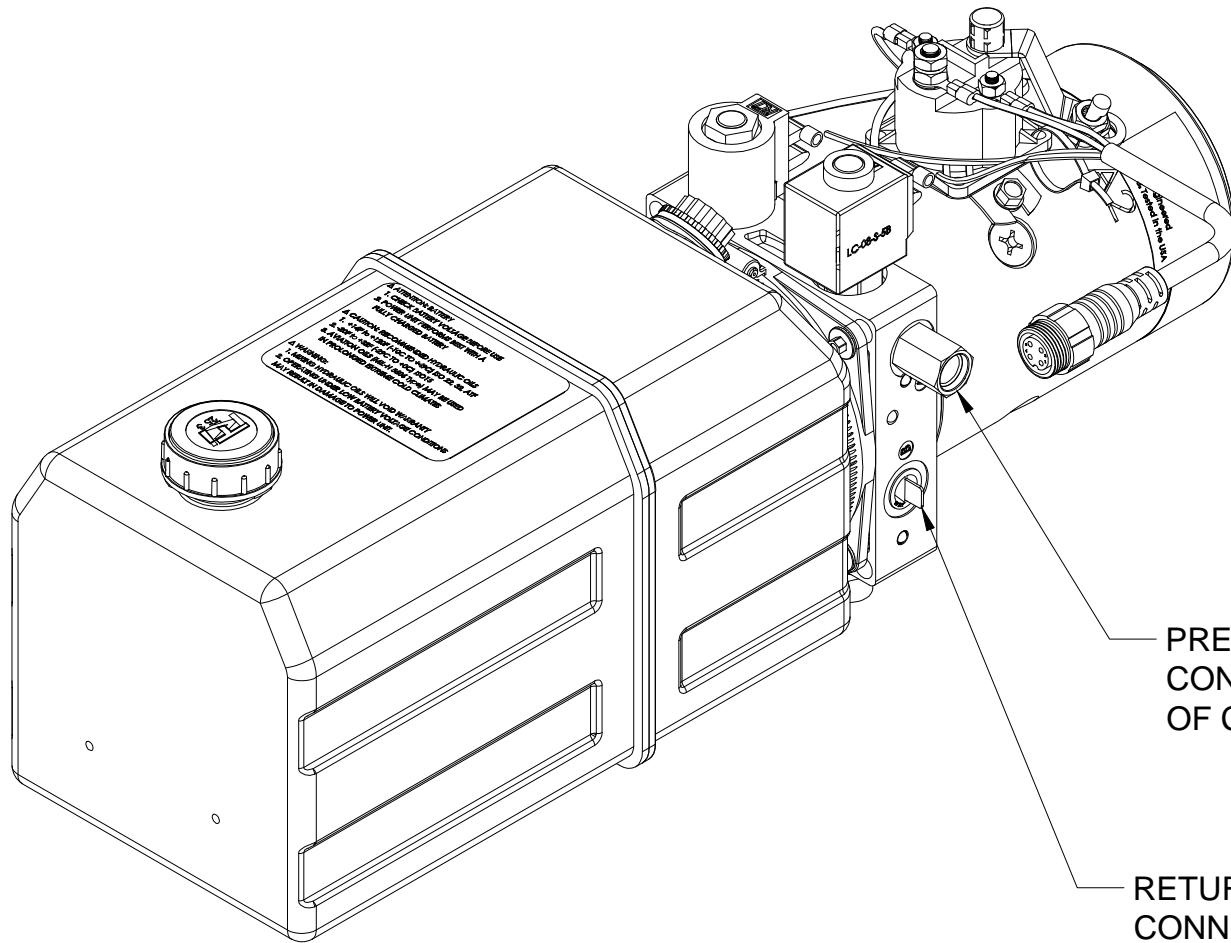

PRESSURE HOSE PORT (A) -
CONNECT TO BASE END
OF CYLINDER

RETURN HOSE PORT (B) -
CONNECT TO ROD END
OF CYLINDER



VENCO VENTURO INDUSTRIES LLC
CINCINNATI, OHIO

TITLE
HYD PORT LOCATIONS - KTI 416081M
VC ED HOISTS

DATE
01-20-25
SUPERSEDES
-

SECTION
H200
416870

HOIST MODELS	ES/ED HYD PWR UNIT PART NUMBER	VP/VC6	TRLR313	VC/TRLR 416	VC/TRLR 516	VC/TRLR 520	VC/TRLR 620	VC/TRLR 628
	RESERVOIR CAPACITY (QUARTS)	3.4 / 3.4	4.6 / 3.4	4.6 / 3.4	4.6 / 3.4	4.6 / 3.4	5.4 / 3.4	5.4 / 3.4
	TOTAL HYDRAULIC FLUID REQUIRED (QUARTS)	4	4	6	8	9	12	15
STEP 1	Attach base-end hose to cylinder. Do NOT attach the Rod-end hose at this time.	YES	YES	YES	YES	YES	YES	YES
STEP 2	Fill the hydraulic reservoir as recommended below. (see fluid note below)							
2a	With the hoist in the down position, add the indicated amount (quarts) of hydraulic fluid.	2	2	3.5	3.5	3.5	3.5	3.5
2b	Raise hoist one-quarter of the way (approximately 12° dumonig angle) and add the indicated amount (quarts) of hydraulic fluid.	-	-	-	1	1.5	2	3
2c	Raise hoist one-half of the way (approximately 22-25° dumping angle) and add the indicated amount (quarts) of hydraulic fluid.	2	2	1.5	1	1.5	2	3
2d	Raise hoist three-quarters of the way (approximately 36° dumping angle) and add the indicated amount (quarts) of hydraulic fluid.	-	-	-	1	1.5	2	3
2e	Raise hoist completely (45-50° dumping angle) and add the indicated amount (quarts) of hydraulic fluid. DO NOT "TOP OFF", or you will likely have overflow when the hoist is lowered.	0	0	1	1.5	1	2.5	2.5
STEP 3	Attach the remaining hose to the rod-end of the cylinder (not req'd on VP/VC6 & TRLR313 hoists w/ ES hyd. Power unit).	ED ONLY	ED ONLY	YES	YES	YES	YES	YES

Hydraulic fluid:

Electric power units - ISO AW46 or Dextron III (type 3) ATF

PTO power units - ISO AW46 (cold climates), ISO AW68 (warm climates)



VENCO VENTURO INDUSTRIES LLC
CINCINNATI, OHIO

TITLE

FILLING HYDRAULIC RESERVOIR

VP/VC6-628, TRLR 313-628

DATE

11-04-15F

SUPERSEDES

08-21-15E

SECTION

-

416140

Included with your Venco hoist are various danger, warning, and caution decals. These decals must be placed in prominent locations so they are easily seen and readily identifiable. This illustration provides the recommended decal locations.

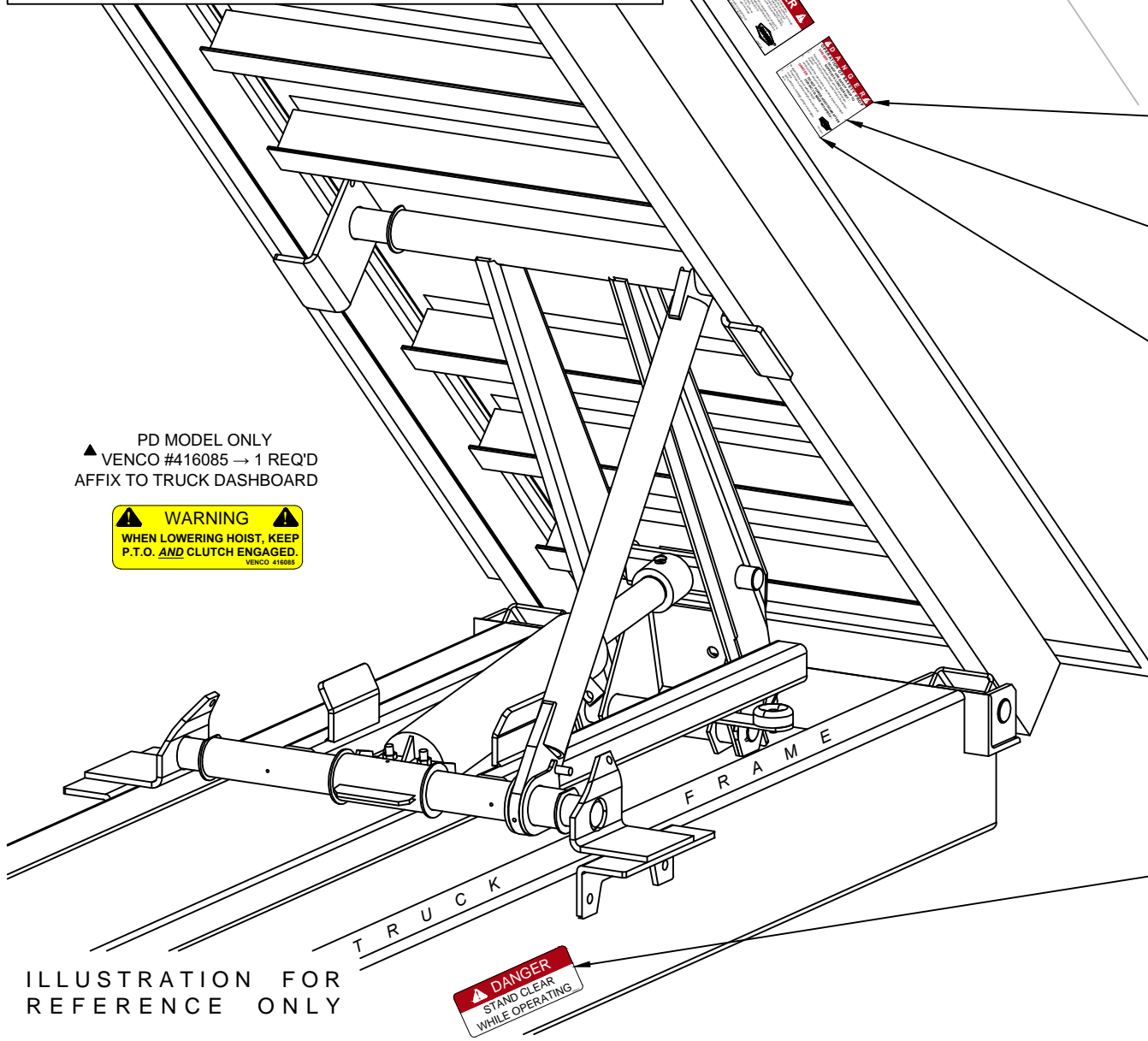

PD MODEL ONLY
 ▲ VENCO #416085 → 1 REQ'D
 AFFIX TO TRUCK DASHBOARD

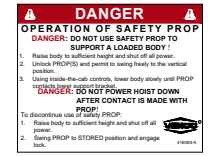

ILLUSTRATION FOR
 REFERENCE ONLY

VENCO #416052
 2 REQ'D (1 EACH SIDE)



VENCO #416084
 1 REQ'D FOR EACH SIDE
 SAFETY PROP
 (SWING-DOWN)



VENCO #416626
 1 REQ'D FOR EACH SIDE
 SAFETY PROP
 (INDEXING)

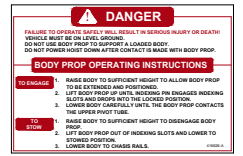

VENCO #416624
 1 REQ'D FOR EACH SIDE
 SAFETY PROP
 (LINKAGE)

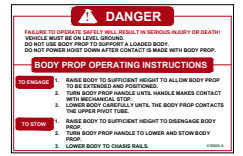

VENCO #15254
 2 REQ'D (1 EACH SIDE)



VENCO VENTURO INDUSTRIES LLC
 CINCINNATI, OHIO

TITLE
 DECAL LOCATIONS

VC416-6628, TRLR416-6628

DATE
 01-29-24G

SUPERSEDES
 10-27-15F

SECTION
 H200

416128

SECTION 250

OPERATION



VENCO VENTURO INDUSTRIES LLC
CINCINNATI, OHIO

HOIST MAINTENANCE AND OPERATION INSTRUCTIONS

- A. Hoist unit lubrication
1. Lubricate all grease fittings on the hoist unit.
 2. Lubricate the rear hinge assembly.
 3. The hoist system should be serviced at the same time the truck is serviced, and sooner if the hoist unit is performing heavy duty service.
 4. Pump Reservoir → Shall be filled with the recommended oil per the manufacturer's instructions. Periodically check the hydraulic fluid and change when the truck engine oil is changed.
- B. PTO Pump Operation
- With the hoist and body completely installed, cycle the hoist several times to purge the hydraulic system of air. Operate the hoist system per the instructions in this manual and per the PTO manufacturer's instructions.



C A U T I O N



- Do not operate the pump at more than 1000 RPM. Severe hoist system damage could result. The PTO speed to engine speed is governed by the gear ratio of the PTO drive installed in the truck transmission.
- For long service and safety from VC hoists, it is important that the following procedure be followed each time the hoist is operated:

1. Engage the PTO from the truck cab and adjust the engine speed to obtain the correct PTO and lift speed desired.
2. Pull the pump stick out. This will cause the hoist to raise.
3. When the pump has reached its maximum capacity, the pump will bypass through the relief valve. To prevent the pump from bypassing, push the pump knob to the center / middle position. Whenever the pump knob is centered, the hoist will stop moving and hold its position.



C A U T I O N



- Do not allow the pump to bypass for long periods of time, as this will put stress on the hydraulic and electrical systems of the hoist.

4. To lower the hoist, push the pump stick in.
NOTE: The Venco hoist powered by PTO drive pumps must be 'powered down'. Failure to 'power down' will cause the reservoir to overflow.
5. To lock the hoist against the truck frame when it is in the down position, push the pump knob in. When the pump bypasses, place the knob in the center 'hold' position.
6. Disengage PTO from transmission per the manufacturer's instructions.



C A U T I O N



- Do not drive the truck without first disengaging the PTO. Failure to disengage the PTO may result in severe damage to the pump and pump drive unit.



VENCO VENTURO INDUSTRIES LLC
CINCINNATI, OHIO

TITLE

MAINT. & OPER. INSTRC.

DATE

11-05-15D

SECTION

H250 ▲

VC 520-6628

SUPERSEDES

08-12-15C

520079

BODY PROP OPERATION GUIDE - GENERAL INFORMATION

D. Body prop(s): Federal Regulation 1926.601, Paragraph 10, requires the use of a body prop. Accordingly, all Venco hoist units will have included as a standard item a body prop (safety strut). See Paragraphs D.1. & D.2. below.

1. The body prop is designed for use only when the truck body is **empty**. The purpose of the body prop is to provide a safety strut for use when maintenance or inspections are performed on an **unloaded** truck body in the raised position.
2. One [1] body prop shall be furnished for truck bodies up to and including 15 feet. For bodies longer than 15 feet in length, two [2] body props should be used.
3. Venco hoists are equipped with one of three types of body props: **Indexing**, **Swing-down** or **Linkage**. The chart below shows the hoist model number and the corresponding body prop types available.



HOIST BODY PROP CONFIGURATION CHART				
HOIST MODEL	STD. BODY PROP TYPE	OPTIONAL LINKAGE BODY PROP	DUAL BODY PROP	OPERATIONAL DECAL PART NUMBER
VC416/516	INDEXING	OPTIONAL	NOT AVAILABLE	INDEX= 416626, LINKAGE= 416624
VC520	INDEXING	OPTIONAL	NOT AVAILABLE	INDEX= 416626, LINKAGE= 416624
VC620	SWING-DOWN	OPTIONAL	NOT AVAILABLE	SWING-DOWN=416084, LINKAGE=416624
VC628	SWING-DOWN	NOT AVAILABLE	OPTIONAL	SWING-DOWN=416084
VC6620	SWING-DOWN	NOT AVAILABLE	OPTIONAL	SWING-DOWN=416084
VC6628	SWING-DOWN	NOT AVAILABLE	STANDARD	SWING-DOWN=416084

NOTE: For an illustration and operating instructions for each body prop type, see page 416645 in this manual.

4. Special Precautions for Swing-down Body Props -

- Make sure the truck is parked on a **flat level surface**.
- Use a suitable tool to pull out the Spring-loaded release pin (stowage device) to release the body prop from the hoist frame. This will release the body prop allowing it to swing downward to a vertical position.
- Make sure that the body prop is aligned with the body prop foot rest (the body prop will be in a vertical position), then allow the truck body to move downward until the body prop is seated in the foot rest.
NOTE: DO NOT POWER DOWN AFTER MAKING CONTACT WITH BODY PROP FOOT REST
- To disengage the body prop, raise the truck body until the body prop swings freely away from the foot pad. Using a suitable tool, place the tool in a leverage position on the body prop and propel sharply to the left and upward (or to the right and upward) so that the locking pin can be compressed and seated in the locking pin hole. Make certain the body prop is latched securely before the hoist is operated.

WARNING

- Do not place arms, hands, or any part of the body between the truck longitudinals (long beams) or moving parts to pull the body prop release / locking pin.

WARNING

- Do not use the body prop(s) to support a loaded truck body.
- Body prop(s) should be free swinging to a vertical position after the locking pin is released

WARNING

- Read operation of safety strut and caution labels **before** operating the hoist.

WARNING

- Use care when reseating the body prop(s) in the locked position.



VENCO VENTURO INDUSTRIES LLC
CINCINNATI, OHIO

TITLE
BODY PROP OP. GUIDE
VC416 - VC6628 HOISTS

DATE
11-05-15A
SUPERSEDES
5-28-14

SECTION
H250 ▲
416644



BODY PROP OPERATION GUIDE - ILLUSTRATIONS & INSTRUCTIONS

VC416 / VC516 / VC520 (STANDARD) INDEXING BODY PROP

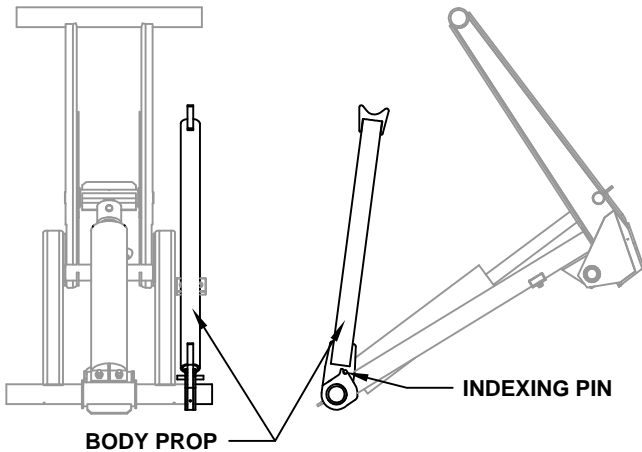

⚠ DANGER

FAILURE TO OPERATE SAFELY WILL RESULT IN SERIOUS INJURY OR DEATH!
VEHICLE MUST BE ON LEVEL GROUND.
DO NOT USE BODY PROP TO SUPPORT A LOADED BODY.
DO NOT POWER HOIST DOWN AFTER CONTACT IS MADE WITH BODY PROP.

BODY PROP OPERATING INSTRUCTIONS

- TO ENGAGE**
1. RAISE BODY TO SUFFICIENT HEIGHT TO ALLOW BODY PROP TO BE EXTENDED AND POSITIONED.
 2. **LIFT BODY PROP UP UNTIL INDEXING PIN ENGAGES INDEXING SLOTS AND DROPS INTO THE LOCKED POSITION.**
 3. LOWER BODY CAREFULLY UNTIL THE BODY PROP CONTACTS THE UPPER PIVOT TUBE.
- TO STOW**
1. RAISE BODY TO SUFFICIENT HEIGHT TO DISENGAGE BODY PROP.
 2. LIFT BODY PROP OUT OF INDEXING SLOTS AND LOWER TO STOWED POSITION.
 3. LOWER BODY TO CHASIS RAILS.

416626-A

▲ VC620 (STANDARD) SWING-DOWN BODY PROP

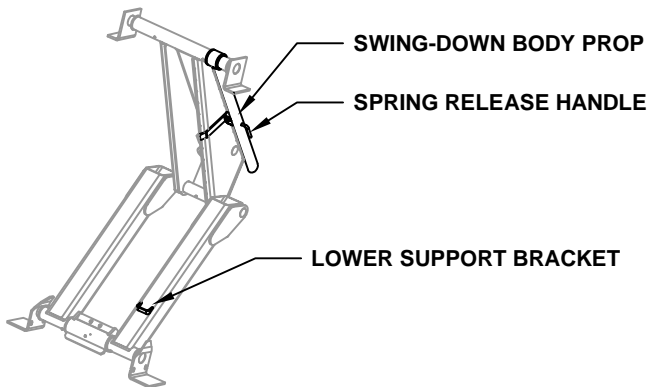

⚠ D A N G E R ⚠

OPERATION OF SAFETY PROP

DANGER: DO NOT USE SAFETY PROP TO SUPPORT A LOADED BODY!

1. Raise body to sufficient height and shut off all power.
2. Unlock PROP(S) and permit to swing freely to the vertical position.
3. Using inside-the-cab controls, lower body slowly until PROP contacts lower support bracket.

DANGER: DO NOT POWER HOIST DOWN AFTER CONTACT IS MADE WITH PROP!

To discontinue use of safety PROP:

1. Raise body to sufficient height and shut off all power.
2. Swing PROP to STORED position and engage lock.



416084-A

NOTE: DUAL BODY PROPS ARE STANDARD ON HOIST MODEL VC6628. REFER TO THE HOIST BODY PROP CONFIGURATION CHART ON DRAWING 416644 TO DETERMINE THE AVAILABILITY OF DUAL BODY PROPS FOR OTHER HOIST MODELS.

VC516 / VC520 / VC620 (OPTIONAL) LINKAGE BODY PROP

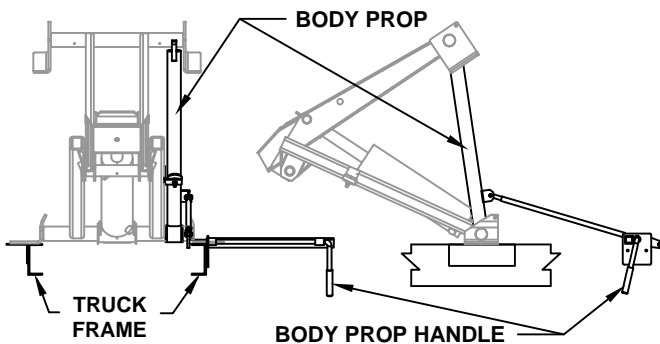

NOTE: THE LINKAGE BODY PROP OPTION ALLOWS THE OPERATOR TO POSITION THE BODY PROP FROM OUTSIDE OF THE BODY FOR ADDED SAFETY. ASK YOUR SALES REPRESENTATIVE FOR MORE INFORMATION.

⚠ DANGER

FAILURE TO OPERATE SAFELY WILL RESULT IN SERIOUS INJURY OR DEATH!
VEHICLE MUST BE ON LEVEL GROUND.
DO NOT USE BODY PROP TO SUPPORT A LOADED BODY.
DO NOT POWER HOIST DOWN AFTER CONTACT IS MADE WITH BODY PROP.

BODY PROP OPERATING INSTRUCTIONS

- TO ENGAGE**
1. RAISE BODY TO SUFFICIENT HEIGHT TO ALLOW BODY PROP TO BE EXTENDED AND POSITIONED.
 2. **TURN BODY PROP HANDLE UNTIL HANDLE MAKES CONTACT WITH MECHANICAL STOP.**
 3. LOWER BODY CAREFULLY UNTIL THE BODY PROP CONTACTS THE UPPER PIVOT TUBE.
- TO STOW**
1. RAISE BODY TO SUFFICIENT HEIGHT TO DISENGAGE BODY PROP.
 2. TURN BODY PROP HANDLE TO LOWER AND STOW BODY PROP.
 3. LOWER BODY TO CHASIS RAILS.

416624-A



VENCO VENTURO INDUSTRIES LLC
CINCINNATI, OHIO

TITLE	DATE	SECTION
BODY PROP OPERATIONS	12-18-15B	H250
VC416 - VC620 HOISTS ▲	SUPERSEDES 11-05-15A	416645

SECTION 300

MAINTENANCE

&

SERVICE



VENCO VENTURO INDUSTRIES LLC
CINCINNATI, OHIO

HOIST GREASE POINTS

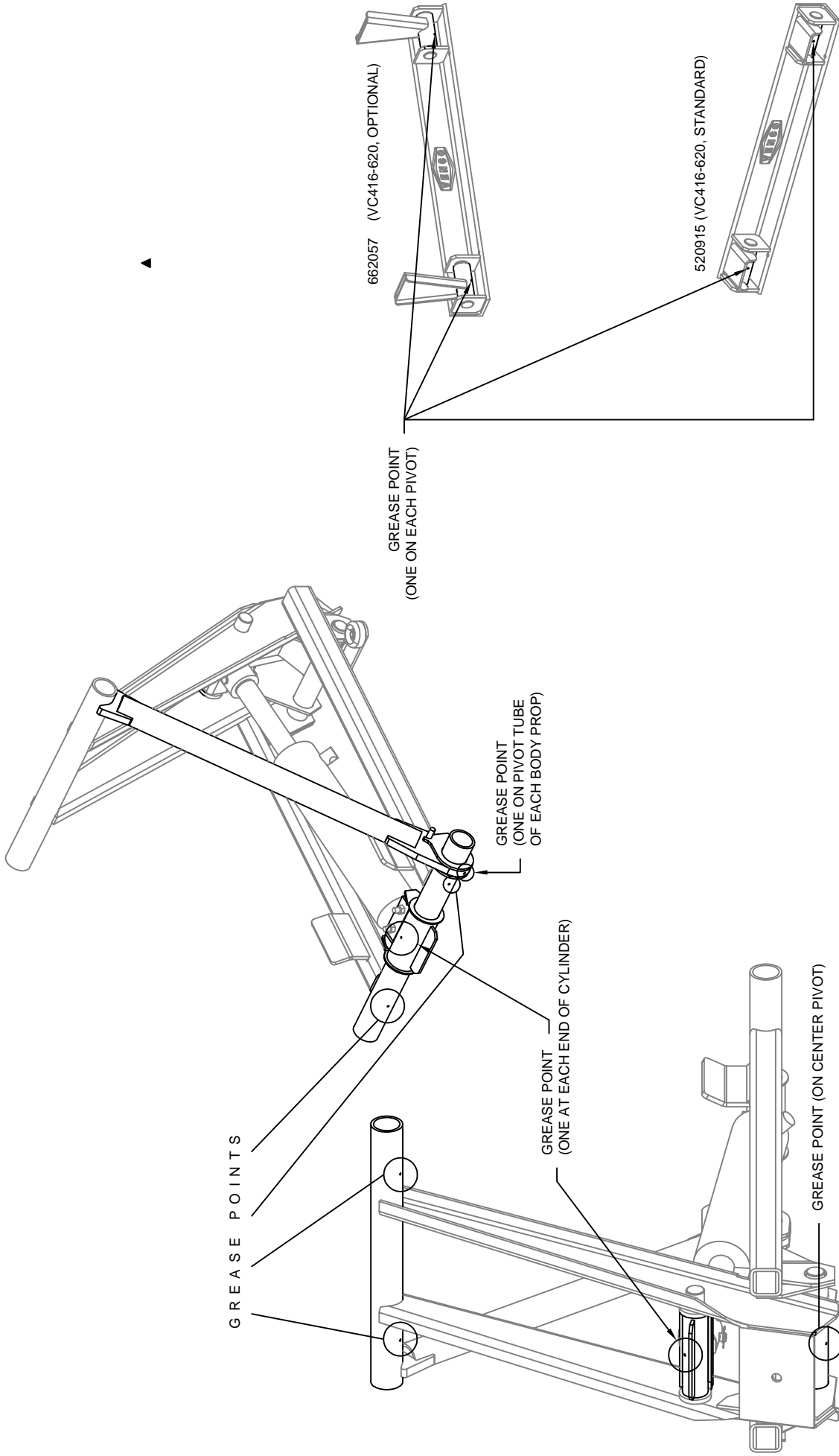

TO ENSURE THE RELIABLE PERFORMANCE OF YOUR VENCO HOIST, IT IS NECESSARY THAT YOU GREASE THE HOIST AT THE TIME OF TRUCK SERVICE WITH CHASSIS GREASE. THE GREASE POINTS FOR THE HOIST SCISSORS AND REAR HINGES ARE SHOWN ABOVE. ADDITIONAL FITTINGS FOR TWIN CYLINDER HOISTS AND ADDITIONAL BODY PROPS ARE ALSO NOTED.



VENCO VENTURO INDUSTRIES LLC
CINCINNATI, OHIO

TITLE
GREASE POINTS FOR HOISTS

VC416-620 ▲

DATE
12-18-15F

SUPERSEDES
10-27-15E

SECTION

-

520054

SECTION 400

REPLACEMENT PARTS



VENCO VENTURO INDUSTRIES LLC
CINCINNATI, OHIO

PART NO.: 416052
 DECAL: DANGER STAY CLEAR
 FUNCTION: To provide operator with a summary of key hoist operating procedures.
 QUANTITY: 2
 PLACEMENT: One on each side of body.

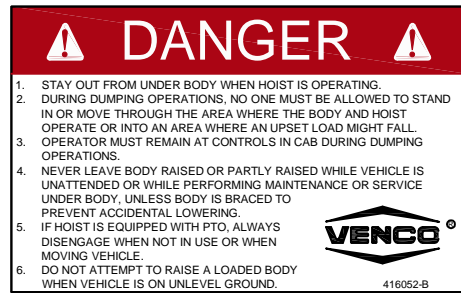

▲
 PART NO.: 416084 (VC620-VC6628 MODELS ONLY)
 DECAL: SAFETY PROP OPERATION
 FUNCTION: To inform the operator of proper operation of safety prop.
 QUANTITY: 1 For each safety prop.
 PLACEMENT: On side of body closest to safety prop(s).

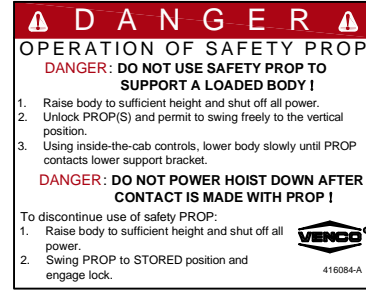

▲
 PART NO.: 416626 (VC416,516 & 520 MODELS ONLY)
 DECAL: SAFETY PROP OPERATION, 'INDEXING' ONLY
 FUNCTION: To inform the operator of proper operation of safety prop.
 QUANTITY: 1 For each safety prop.
 PLACEMENT: On side of body closest to safety prop(s).

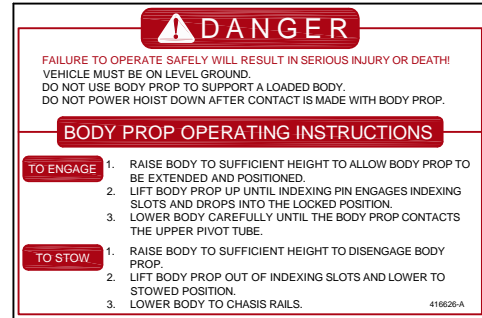

PART NO.: 15254
 DECAL: CAUTION STAND CLEAR
 FUNCTION: To inform the operator to stay clear of body / hoist.
 QUANTITY: 2
 PLACEMENT: One on each side of truck frame.



PART NO.: 416085
 DECAL: WARNING WHEN LOWERING
 FUNCTION: To inform the operator to keep P.T.O. and clutch engaged when lowering the hoist.
 QUANTITY: 1
 PLACEMENT: Affixed to truck dashboard.



	Venco VENTURO INDUSTRIES LLC CINCINNATI, OHIO	TITLE	DATE	SECTION
		DECAL LIST	11-05-15E	-
		VC/TRLR 416-6628	SUPERSEDES 03-26-14D	628820

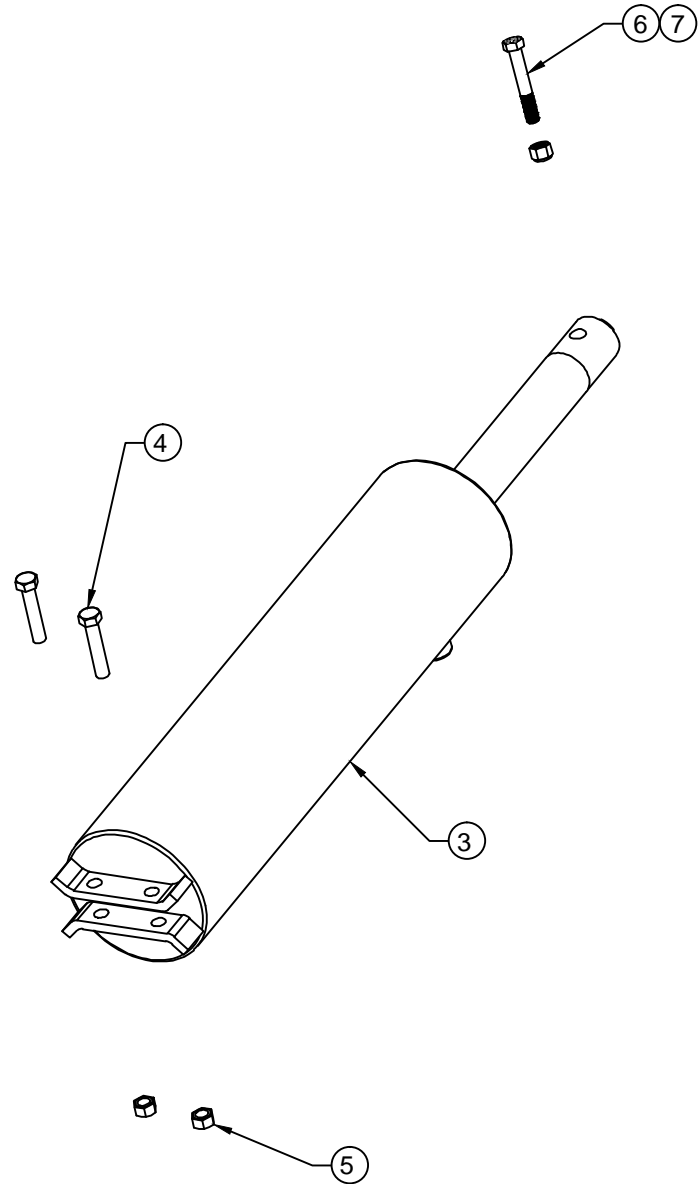

**NON-SUBFRAME
(MOUNTING ANGLES)**

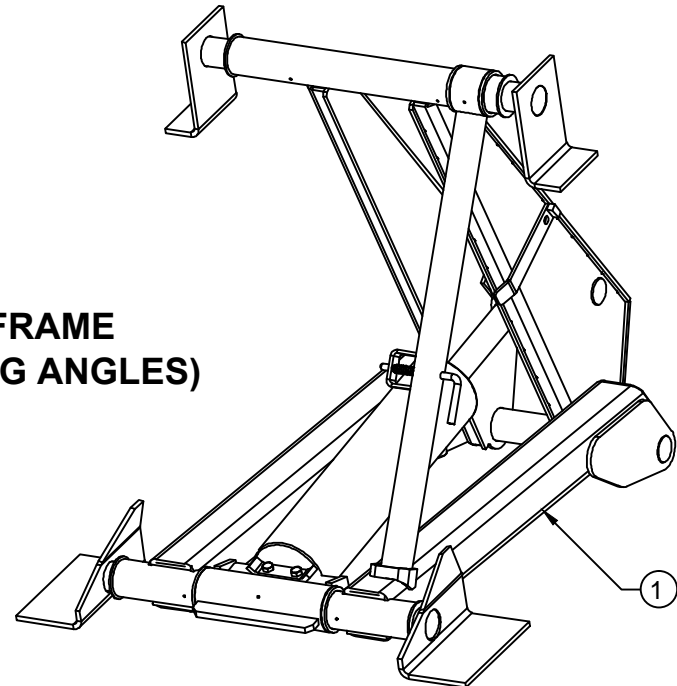

**SUBFRAME
(MOUNTING ANGLES)**

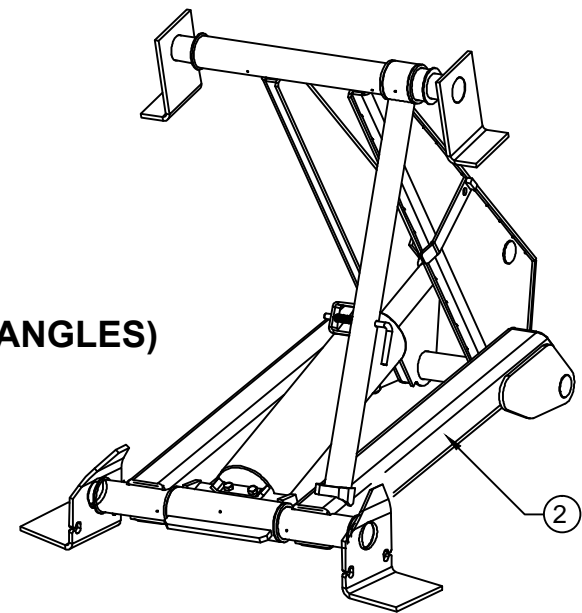

REPLACEMENT PARTS LIST REFERENCE 620120



VENCO VENTURO INDUSTRIES LLC
CINCINNATI, OHIO

TITLE	DATE	SECTION
RELACEMENT PARTS DRAWING	11-15-23D	H400
VC620 HOIST- (Subframe & Non-subframe)	SUPERSEDES 06-30-21C	620119

620119 REPLACEMENT PARTS LIST

ITEM	PART NUMBER	QTY.	DESCRIPTION
1	620203	1	SCISSORS ASSEMBLY (NON-SUBFRAME)
2	620203-SF	1	SCISSORS ASSEMBLY (SUB-FRAME)
3	620907	1	HYDRAULIC CYLINDER
4	!HHCS05013275-8	2	HEX HEAD CAP SCREW; 1/2-13 X 2-3/4" LG. GR. 8
5	!LNUT-05013	2	LOCK NUT; 1/2-13, NYLON
▲ 6	!HHCS06311400-8	1	HHCS; 5/8-11 X 4 GR. 8
▲ 7	!LNUT-06311-8	1	LOCK NUT; 5/8-11, GR. 8, ZNC/YLW, NYL-INSERT
8	-	-	-
9	-	-	-
10	-	-	-
11	-	-	-
12	-	-	-
13	-	-	-
14	-	-	-
15	-	-	-
16	-	-	-
17	-	-	-
18	-	-	-
19	-	-	-
20	-	-	-
21	-	-	-
22	-	-	-
23	-	-	-
24	-	-	-
25	-	-	-
26	-	-	-
27	-	-	-
28	-	-	-
29	-	-	-
30	-	-	-
31	-	-	-
32	-	-	-
33	-	-	-
34	-	-	-
35	-	-	-

REPLACEMENT PARTS DWG REF 620119



VENCO VENTURO INDUSTRIES LLC
CINCINNATI, OHIO

TITLE
RPLCMNT PARTS LIST

DATE
11-15-23E

SECTION
H400

VC620

SUPERSEDES
06-30-21D

620120

VC620 W/ OPTIONAL LINKAGE BODY PROP

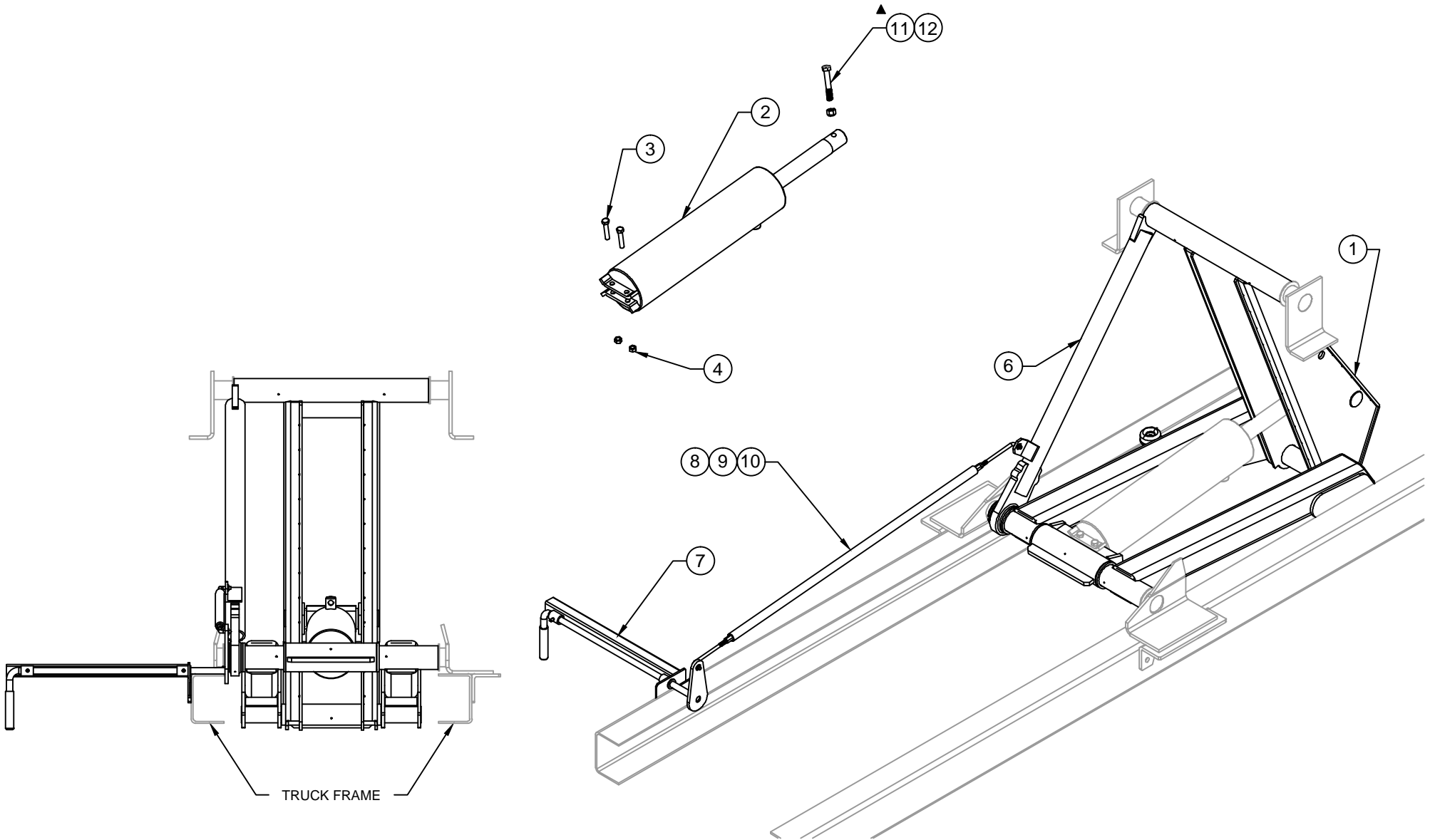

NOTE: THE LINKAGE BODY PROP OPTION ALLOWS OPERATOR TO POSITION THE BODY PROP FROM OUTSIDE OF THE BODY FOR ADDED SAFETY. ASK YOUR SALES REPRESENTATIVE FOR MORE INFORMATION.

REPLACEMENT PARTS LIST REFERENCE 620134



VENCO VENTURO INDUSTRIES LLC
CINCINNATI, OHIO

TITLE	DATE	SECTION
REPLACEMENT PARTS DRAWING	11-15-23D	H400
VC620 W/ OPTIONAL LINKAGE BODY PROP	SUPERSEDES 11-18-15C	620133

620133 REPLACEMENT PARTS LIST

ITEM	PART NUMBER	QTY.	DESCRIPTION
1	620203	1	SCISSORS ASSEMBLY
2	620907	1	HYDRAULIC CYLINDER
3	!HHCS05013275-8	2	HEX HEAD CAP SCREW; 1/2-13 X 2-3/4" LG. GR. 8
4	!LNUT-05013	2	LOCK NUT; 1/2-13, NYLON
5	-	-	-
6	620025	1	BODY PROP, WELDED ASSY.
7	520638-ALT01	1	HANDLE, WELDED ASSY.
8	520638-1	1	LINKAGE ROD ASSY., 31" LONG
9	520633-2	1	LINKAGE ROD ASSY., 15" LONG
10	520633-3	1	LINKAGE ROD ASSY., 55 1/4" LONG
▲ ▲	11 !HHCS06311400-8	1	HHCS; 5/8-11 X 4 GR. 8
12	!LNUT-06311-8	1	LOCK NUT; 5/8-11, GR. 8, ZNC/YLW, NYL-INSERT
13	-	-	-
14	-	-	-
15	-	-	-
16	-	-	-
17	-	-	-
18	-	-	-
19	-	-	-
20	-	-	-
21	-	-	-
22	-	-	-
23	-	-	-
24	-	-	-
25	-	-	-
26	-	-	-
27	-	-	-
28	-	-	-
29	-	-	-
30	-	-	-
31	-	-	-
32	-	-	-
33	-	-	-
34	-	-	-
35	-	-	-

REPLACEMENT PARTS DWG REF 620133



VENCO VENTURO INDUSTRIES LLC
CINCINNATI, OHIO

TITLE
RPLCMNT PARTS LIST

DATE
11-15-23F

SECTION
H400

SUPERSEDES
VC620 - OPT. LNKG PROP

11-10-15E

620134

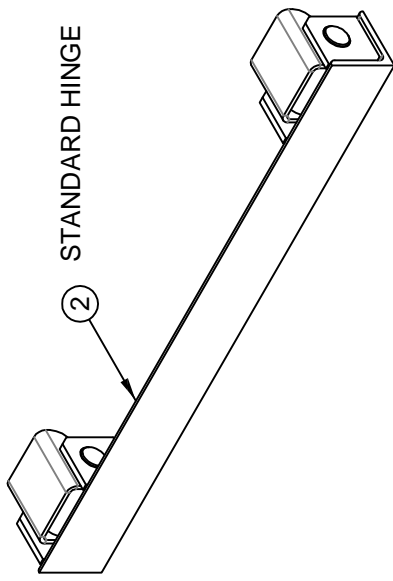

STANDARD HINGE

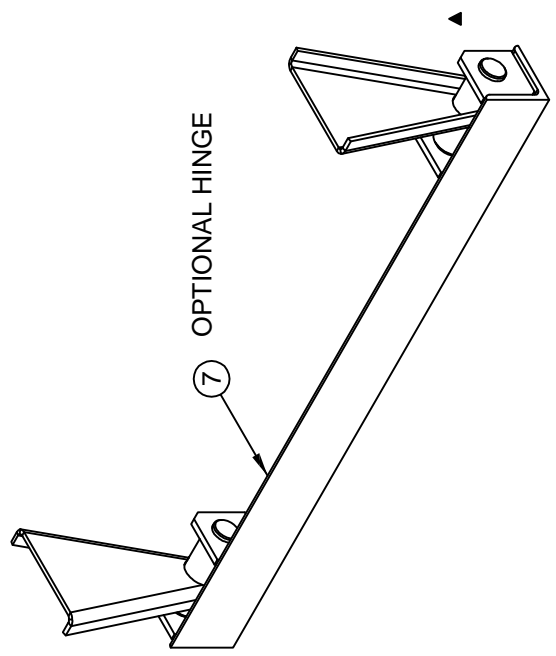

OPTIONAL HINGE

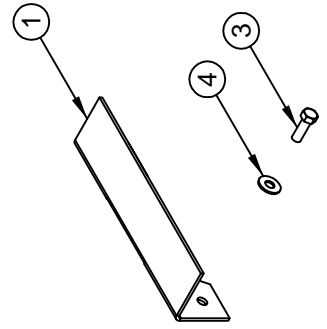
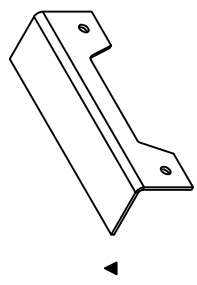

REPLACEMENT PARTS LIST REF 620118

 <p>VENCO® VENCO VENTURO INDUSTRIES LLC CINCINNATI, OHIO</p>	TITLE	SECTION
	<p>REPLACEMENT PARTS DRAWING</p> <p>VC620 (NON-SUBFRAME)</p>	<p>H400</p>
	DATE	
	<p>11-10-15B</p> <p>SUPERSEDES</p> <p>06-17-03</p>	
		<p>620117</p>

620117 REPLACEMENT PARTS LIST

ITEM	PART NUMBER	QTY.	DESCRIPTION
▲ 1	520920	2	FRAME MOUNTING ANGLE
▲ 2	520915	1	REAR HINGE ASSEMBLY (STANDARD)
3	!HHCS05012150	4	HEX HEAD CAP SCREW; 1/2-13 x 1-1/2" L
4	!FWSH-050	8	FLAT WASHER; 1/2"
5	!LWSH-050	4	LOCK WASHER; 1/2"
▲ 6	!HNUT-05013	4	HEX NUT; 1/2-13
7	662057	1	REAR HINGE ASSEMBLY (OPTIONAL)
8	-	-	-
9	-	-	-
10	-	-	-
11	-	-	-
12	-	-	-
13	-	-	-
14	-	-	-
15	-	-	-
16	-	-	-
17	-	-	-
18	-	-	-
19	-	-	-
20	-	-	-
21	-	-	-
22	-	-	-
23	-	-	-
24	-	-	-
25	-	-	-
26	-	-	-
27	-	-	-
28	-	-	-
29	-	-	-
30	-	-	-
31	-	-	-
32	-	-	-
33	-	-	-
34	-	-	-
35	-	-	-

REPLACEMENT PARTS DWG REF 620117



VENCO VENTURO INDUSTRIES LLC
CINCINNATI, OHIO

TITLE
RPLCMENT PARTS LIST

DATE
11-10-15C

SECTION
H400 ▲

VC620 (NON SUB-FRAME)

SUPERSEDES
05-22-06A

620118

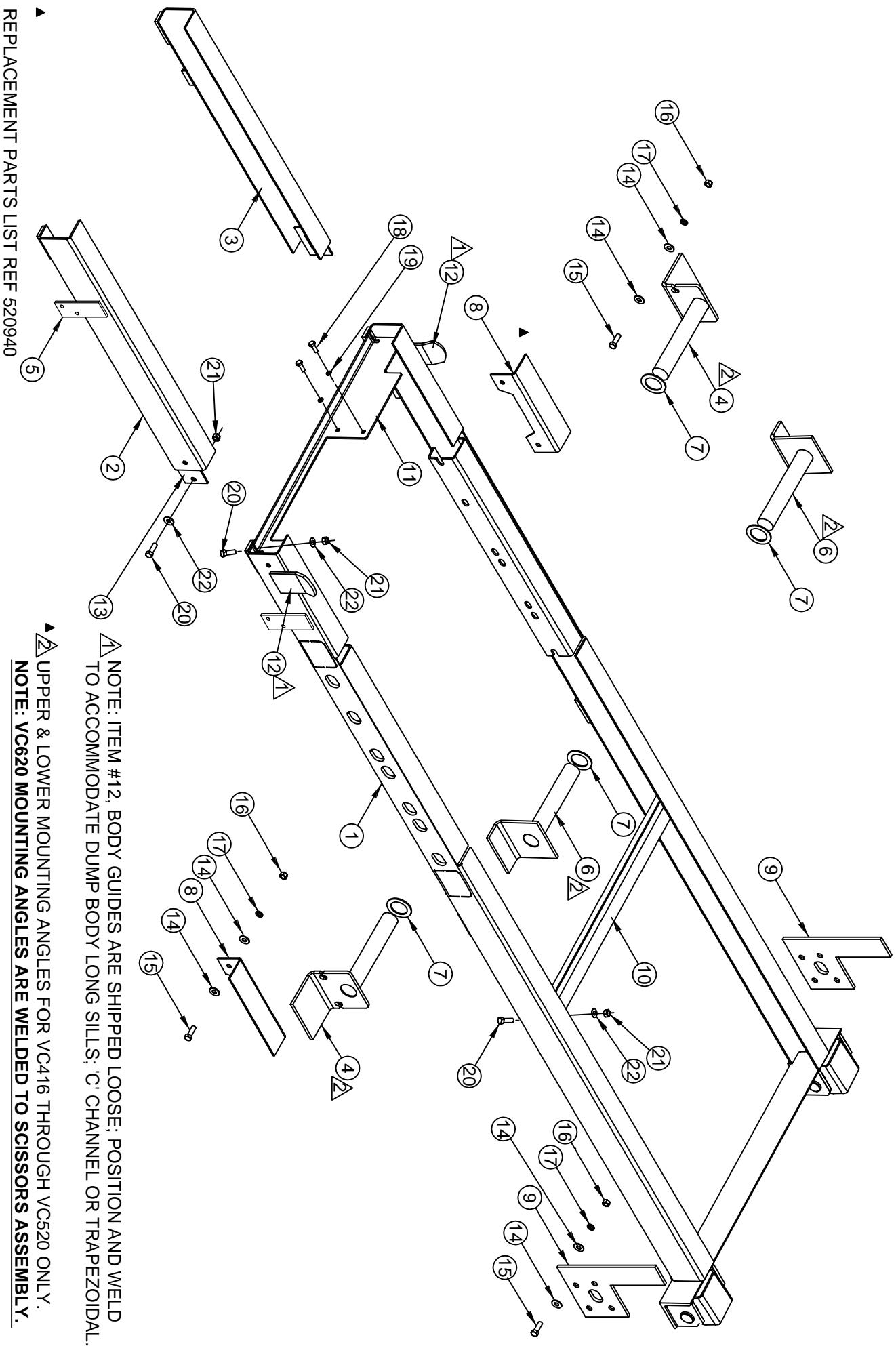

REPLACEMENT PARTS LIST REF 520940

▲ NOTE: ITEM #12, BODY GUIDES ARE SHIPPED LOOSE; POSITION AND WELD TO ACCOMMODATE DUMP BODY LONG SILLS; 'C' CHANNEL OR TRAPEZOIDAL.
 ▲ UPPER & LOWER MOUNTING ANGLES FOR VC416 THROUGH VC520 ONLY.
 NOTE: VC620 MOUNTING ANGLES ARE WELDED TO SCISSORS ASSEMBLY.



 VENCO VENTURO INDUSTRIES LLC
 CINCINNATI, OHIO

TITLE	DATE	SECTION
REPLACEMENT PARTS DRAWING	08-16-19E	H400
VC416-620 UNIVERSAL SUB-FRAME	SUPERSIDES 11-05-15D	520939

22	8	IFWSH-038	FLAT WASHER; 3/8"
21	8	ILNUT-03816	LOCK NUT; 3/8-16, NYLON
20	8	IHHCS03816125	HEX HEAD CAP SCREW (HHCS); 3/8-16 X 1-1/4" LG, GR. 5
19	2	ILWSH-038	LOCK WASHER; 3/8"
18	2	IHHCS03816075	HHCS; 3/8-16 X 3/4" LG, GR. 5
17	12	ILWSH-050	LOCK WASHER; 1/2"
16	12	IHNUT-05013-8	HEX NUT; 1/2-13, GR. 8
15	12	IHHCS05013150-8	HHCS; 1/2-13 X 1-1/2" LG, GR. 8
14	24	IFWSH-050	FLAT WASHER; 1/2"
13	2	520925	JOINER PLATES
12	2	520929	BODY GUIDES; C-CHANNEL & TRAPEZOIDAL
11	1	520918	CROSSMEMBER; HYD. POWER UNIT MNTNG BRACKET
10	1	520919	CROSSMEMBER; SCISSORS SUPPORT
9	2	520932	SHEAR PLATE; FORD S/D
8	2	520920	MOUNTING ANGLE; TRUCK CHASSIS
7	4	416220	COLLAR (ALL PIVOT ASSEMBLIES)
6	2	520923	UPPER PIVOT ASSEMBLY; LEFT & RIGHT (VC416 - VC520)
5	4	520532	FRAME TIE DOWN BRACKET
4	2	520930	LOWER PIVOT ASSEMBLY; LEFT & RIGHT (VC416 - VC520)
3	1	520926-2	EXTENSION; 84" SUB-FRAME, RIGHT
2	1	520926-1	EXTENSION; 84" SUB-FRAME, LEFT
1	1	520912	WELDED ASSEMBLY; UNIVERSAL SUB-FRAME
ITEM	QTY	PART NO.	DESCRIPTION

REPLACEMENT PARTS DWG REF. 520939



VENCO VENTURO INDUSTRIES LLC
CINCINNATI, OHIO

TITLE
REPLACEMENT PARTS LIST
VC416-620 UNIVERSAL SUB-FRAME

DATE
08-16-19E
SUPERSEDES
12-14-18D

SECTION
H400
520940

REPLACEMENT PARTS; 40058M (BUCHER)

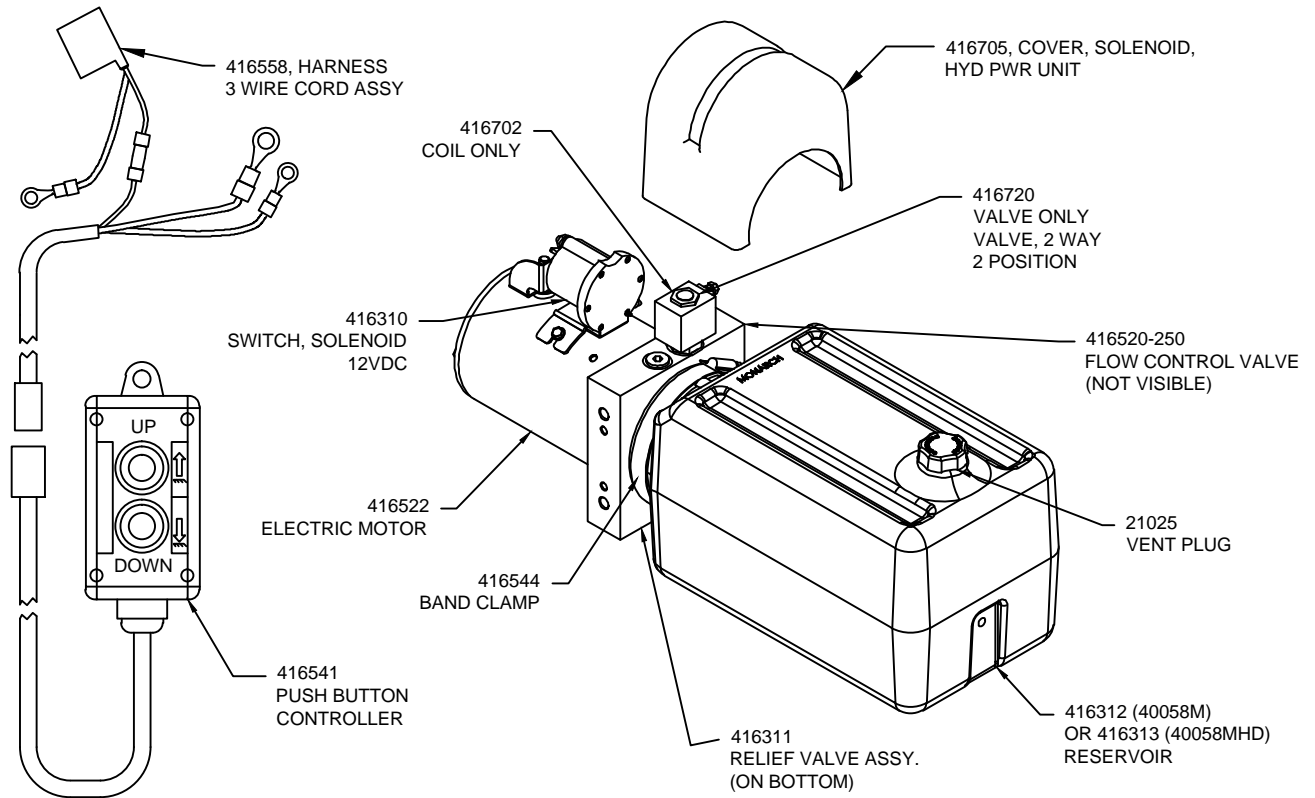

REPLACEMENT PARTS; 40058M (KTI)

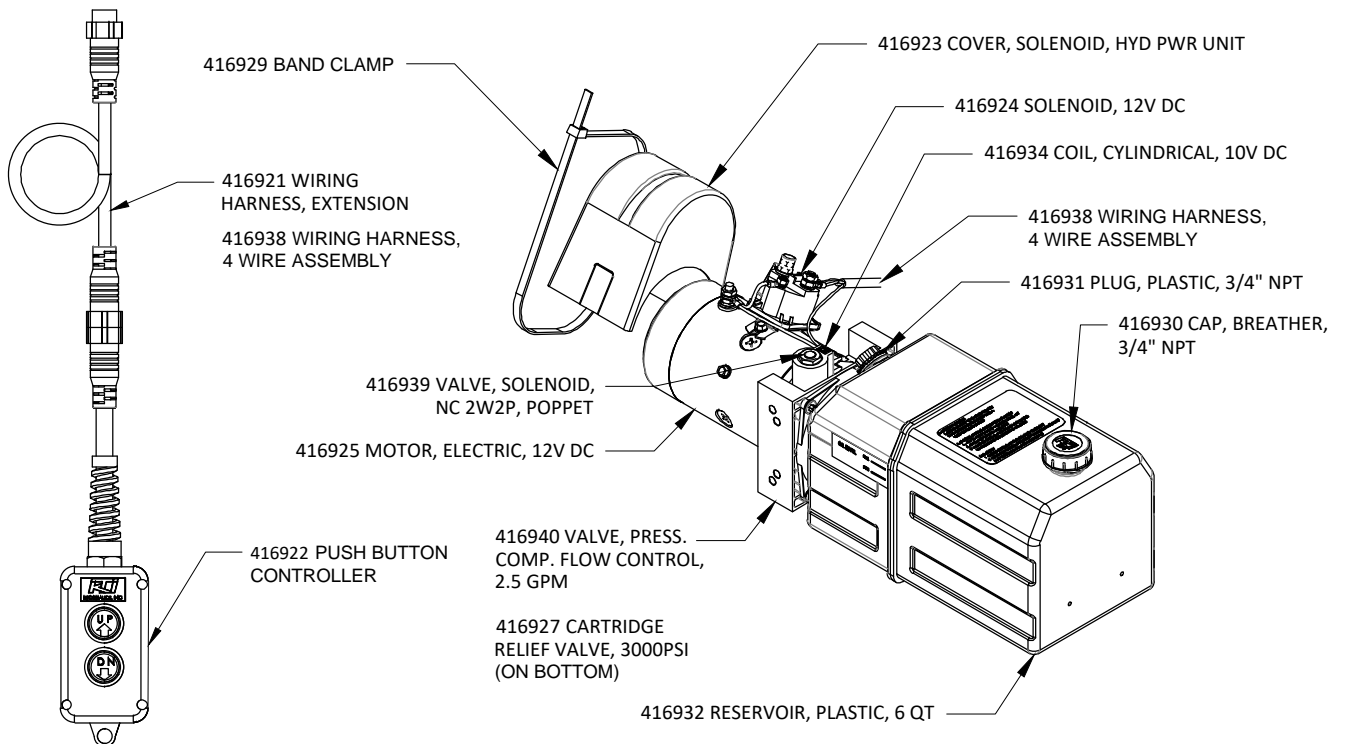

NOT SHOWN: 416937, O-RING, INDUSTRIAL, 113MM ID, C/S 4MM



VENCO VENTURO INDUSTRIES LLC
CINCINNATI, OHIO

TITLE
REPLACEMENT PARTS

DATE
04-09-21H

SECTION
C999

40058M HYD. POWER UNIT

SUPERSEDES
08-21-15G

416308

REPLACEMENT PARTS; 416081M (BUCHER)

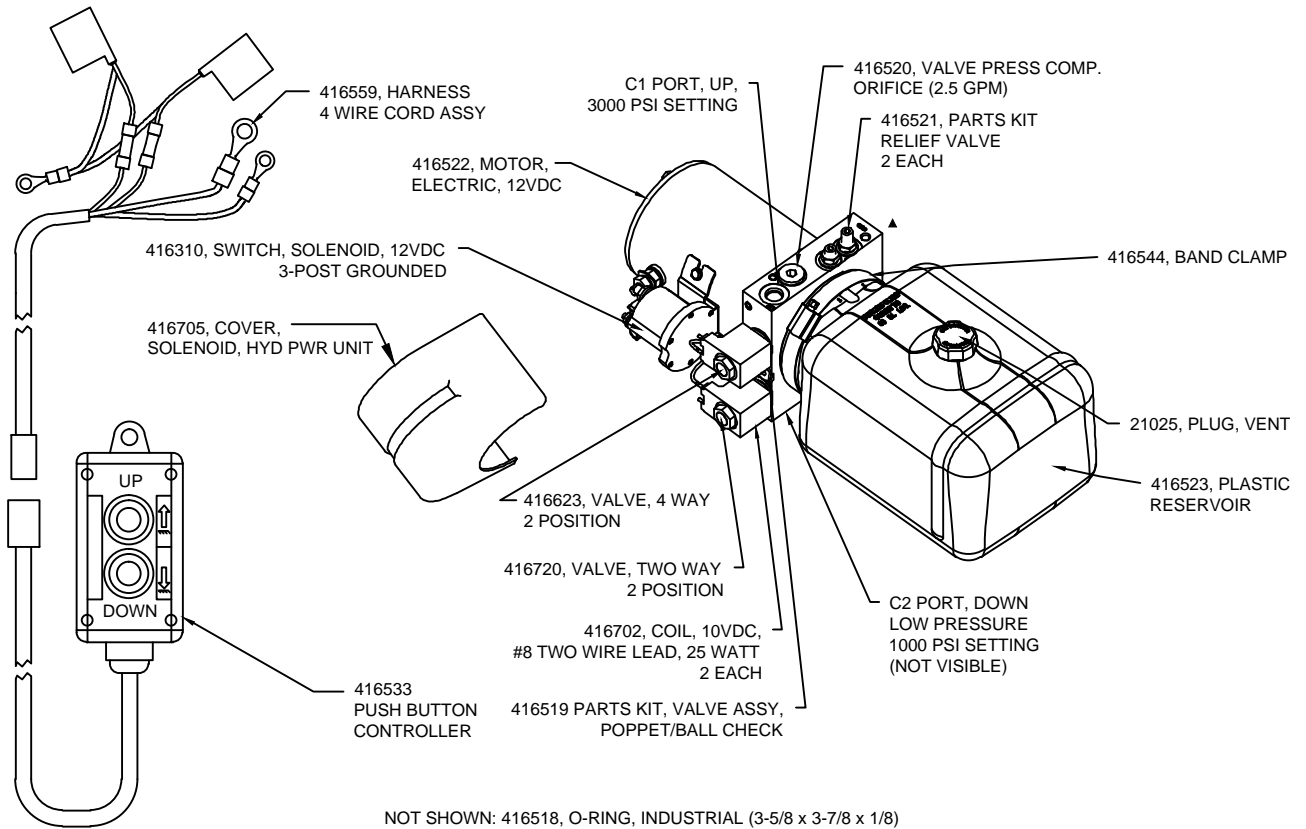

REPLACEMENT PARTS; 416081M (KTI)

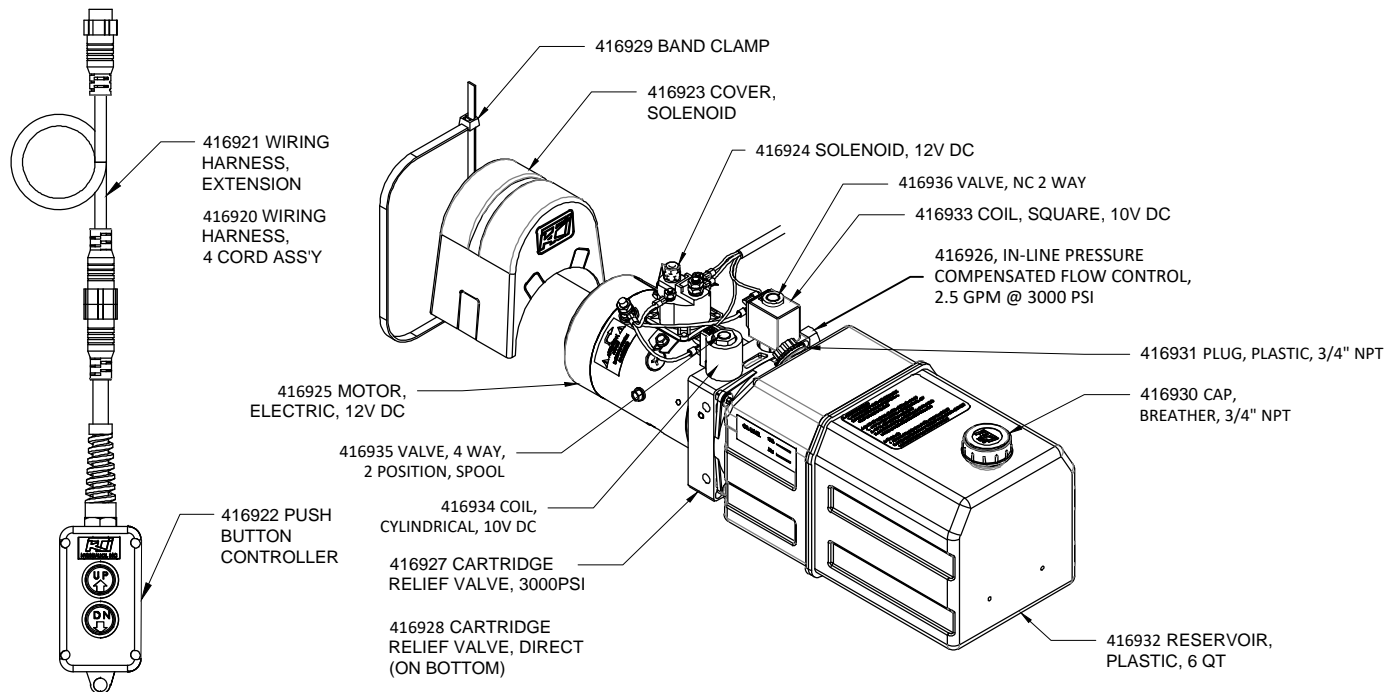

VENCO VENTURO INDUSTRIES LLC
CINCINNATI, OHIO

TITLE
REPLACEMENT PARTS

DATE
04-09-21K

SECTION
H400

416081M HYD. POWER UNIT

SUPERSEDES
05-07-20J

416508

CABLE & CONSOLE KITS; 620125 (CURVED) & 620124 (STRAIGHT)

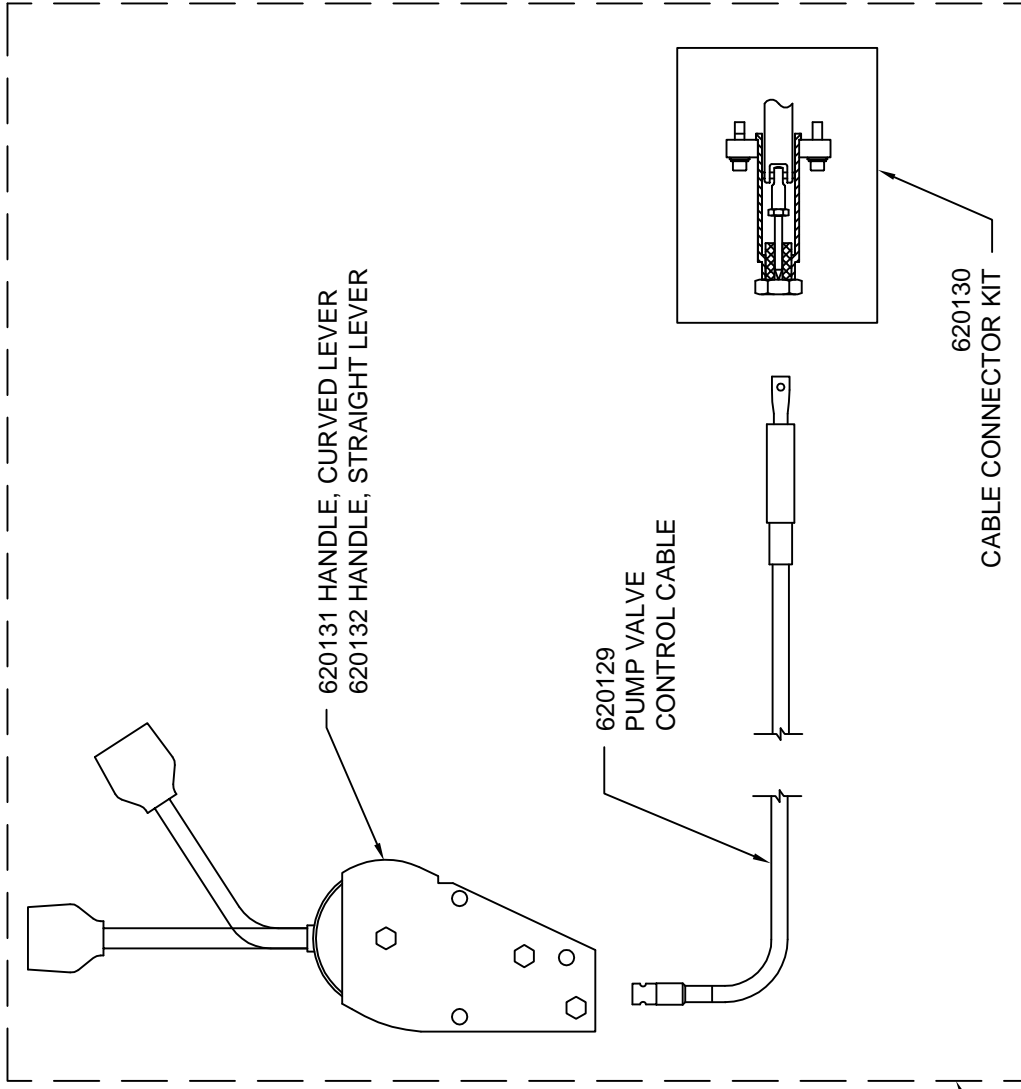
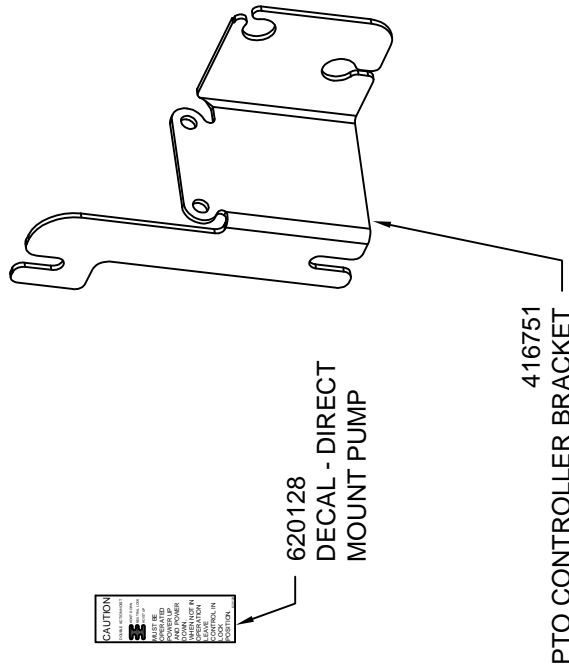
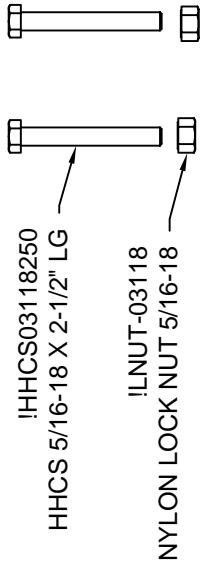

620126 CURVED HANDLE CABLE ASSEMBLY
620127 STRAIGHT HANDLE CABLE ASSEMBLY



VENCO VENTURO INDUSTRIES LLC
CINCINNATI, OHIO

TITLE
REPLACEMENT PARTS DWG & LIST

DATE
10-29-15B

SUPERSEDES
03-17-14A

SECTION
H400

620245



VENCO HOISTS LIMITED WARRANTY POLICY

Venco products are built to last...we guarantee them.

As a purchaser of any new Venco product covered by warranty, you will receive 3 years of the most complete coverage available...and, at no added cost to you.

3-Year Limited Warranty Policy

This limited policy warrants new products of Venco to be free from defects in material and workmanship for a period of three (3) years from date of original installation. OEM products or accessories purchased by Venco as part of or offered with our product will carry the OEM manufacturer's respective warranty. Our warranty covers:

- ***Repair or replacement of product***
- ***Labor to repair or replace product***
- ***Freight to return and/or replace product***

We shall not be liable for any contingent liabilities arising out of the improper function of any products. Warranty shall become void if the product is improperly installed, modified, damaged, abused or used for application other than intended use. Venco hoists are designed for and intended to be used on stationary trucks dumping on firm and level ground. Spreading applications and/or shock unloading are strictly prohibited and will void this warranty. There is no warranty of merchantability, fitness for a particular purpose, warranty arising from course of dealing or usage of trade, or any other implied or expressed warranty, except as made specifically herein. This warranty supersedes all previous warranties, written or implied.

Warranty Claims

Venco Venturo Industries LLC will make a good faith effort for prompt correction or other adjustment with respect to any product, which proves to be defective after our inspection and within the warranty period. Before any repairs are attempted or before returning any product, your Venco Distributor is required to obtain a warranty claim number. This number is necessary for any claim to be considered. To obtain a warranty claim number, Venco requires the model and serial number. Only authorized Venco Distributors can perform warranty. For the name and address of your local Venco Distributor call the **Warranty Claim Department - 513-772-8448**.

WARNING - It is the responsibility of the installer to ensure the installation is completed according to the manufacturer's recommendations, ensure the ultimate user understands how to operate product in a safe manner, and understands the need for regular service and maintenance by an authorized Venco Distributor. No modifications or alterations may be made to any Venco product without the expressed written consent of Venco Venturo Industries LLC. Installation of any Venco product must be done by an authorized Venco Distributor, to the standards of the industry; including maintenance, service and affixing of all instruction, safety and warning decals. Users should be instructed as to the safe operation at time of delivery. Maintenance, service, operation and safety warning decals are available on request from Venco Venturo Industries LLC.

VENCO VENTURO INDUSTRIES LLC
12110 BEST PLACE | CINCINNATI, OHIO 45241
P: 800-226-2238 | F: 513-326-5427
www.venturo.com