

PARTS & INSTALLATION MANUAL

27000 SERIES

Included in this manual:

27634-PHX, 27789-PHX, 27695-PHX

- Stabilizer with Hydraulic Pullout and Hydraulic Legs
- Available in “Less Crosstube” (-LC) configuration

VENCO VENTURO INDUSTRIES LLC
12110 BEST PLACE | CINCINNATI, OHIO 45241
800-226-2238



This manual also available online at www.venturo.com.

27000 SERIES

INST-28200 - 1/17/2025 (Rev: A1)

7607200A	SECTION 200: INSTALLATION
25480	INSTALLATION GUIDELINES
25447-1	SELECTOR VALVE OVERVIEW
25485	DEPARTURE ANGLE, REAR-MOUNTED STABILIZERS
28201	LEG MOUNTING
28202	RECOMMENDED MOUNTING - 27634 & 27789
28203	ISOMETRIC VIEW - 27634
28204	OVERALL DIMENSIONS - 27634 LONG LEG
28205	OVERALL DIMENSIONS - 27634 SHORT LEG
28206	HYDRAULIC MAPPING - 27634
28207	LESS-CROSSTUBE ASSY - 27634
28208	ISOMETRIC VIEW - 27789
28209	OVERALL DIMENSIONS - 27789 LONG LEG
28210	OVERALL DIMENSIONS - 27789 SHORT LEG
28211	HYDRAULIC MAPPING - 27789
28212	HYDRAULIC MAPPING - 27634 & 27789
28222	ISOMETRIC VIEW - 27695
28223	RECOMMENDED MOUNTING - 27695
28224	OVERALL DIMENSIONS - 27695 LONG LEG
28225	OVERALL DIMENSIONS - 27695 SHORT LEG
28226	HYDRAULIC MAPPING - 27695
28227	HYDRAULIC MAPPING - 27695

7607400A	SECTION 400: REPLACEMENT PARTS
28213	27634 & 27789 ISO BREAKDOWN
28214	27634 & 27789 CROSSTUBE REPL PARTS LIST
28215	27634 & 27789 CROSSTUBE REPL PARTS DWG
28216	6' PULLOUT REPLACEMENT PARTS LIST
28217	6' PULLOUT REPLACEMENT PARTS DWG
28218	4' PULLOUT REPLACEMENT PARTS LIST
28219	4' PULLOUT REPLACEMENT PARTS DWG
28220	LEG REPLACEMENT PARTS LIST
28221	LEG REPLACEMENT PARTS DRAWING
28228	27695 ISO BREAKDOWN
28229	27695 CROSSTUBE REPL PARTS LIST
28230	27695 CROSSTUBE REPL PARTS DWG
28231	5' PULLOUT REPLACEMENT PARTS LIST
28232	5' PULLOUT REPLACEMENT PARTS DWG
28233	LONG LEG REPLACEMENT PARTS LIST
28234	LONG LEG REPLACEMENT PARTS DRAWING
28235	SHORT LEG REPLACEMENT PARTS LIST
28236	SHORT LEG REPLACEMENT PARTS DRAWING

12-00073_VNT1	WARRANTY PAGE
---------------	---------------

SECTION 200

INSTALLATION



VENCO VENTURO INDUSTRIES LLC
CINCINNATI, OHIO

STABILIZER INSTALLATION GUIDELINES

Read instructions completely prior to starting installation. If this unit is to be installed on a Venturo crane body, continue to the stabilizer assembly section of this manual.

Prior to mounting the stabilizer crosstube, orient the stabilizer so the longer pullout is on the crane side of the truck.

REAR MOUNTED

Crosstube should be centered at the rear of the truck and tied into the truck frame, body longills, and crane support. Installer is responsible for proper mounting brackets and hardware that will be needed during this process. If unit is to be mounted on a service body, do not attach crosstube to body sheet metal unless otherwise specified. Allow clearance between crosstube and body for the stabilizer legs to be fully retracted. Consult chassis up-fitter guide prior to installation for proper welding and bolting procedures to chassis.

See the 'RECOMMENDED MOUNTING TO TRUCK FRAME' page

Leg installation (refer to assembly section of manual) legs are adjustable to maintain proper ground penetration of 4" to 6". The stabilizer is designed to level the truck and not lift the chassis off of the ground. They are designed to work in conjunction with the chassis suspension to stabilize the unit with the bulk of the load being supported by the chassis suspension and tires. Tires must be set at the proper pressure according to the chassis manufacture, stabilizers fully extended, and legs deployed on firm, level ground prior to crane use.

IMPORTANT - When legs are fully retracted in the stowed position, a 15° degree departure angle between the bottom of the rear tire and the lowest point of the stabilizer is recommended.

See the 'DEPARTURE ANGLE' page

For hydraulic stabilizers, the control valve and selector valve are supplied in kit. It is the installer's responsibility to supply necessary hoses and fittings between these valves and stabilizer. Refer to proper hydraulic schematic for your particular stabilizer model.

IMPORTANT - The selector valve is designed to separate the crane and stabilizer hydraulic circuits. This will not allow stabilizer use while in crane mode.

FRONT MOUNTED

Front mounted crosstube will be located on top of the chassis frame and welded to body longills. Additional shear plates (installer supplied) to be welded to crosstube and bolted to chassis frame. Crosstube to be spaced away from body for leg clearance when fully retracted. See assembly section of manual for pullout and leg installation detail.



VENCO VENTURO INDUSTRIES LLC
CINCINNATI, OHIO

INSTALLATION GUIDELINES

DATE

12-08-23A

SECTION

C200

STABILIZERS

SUPERSEDES

01-17-17

25480

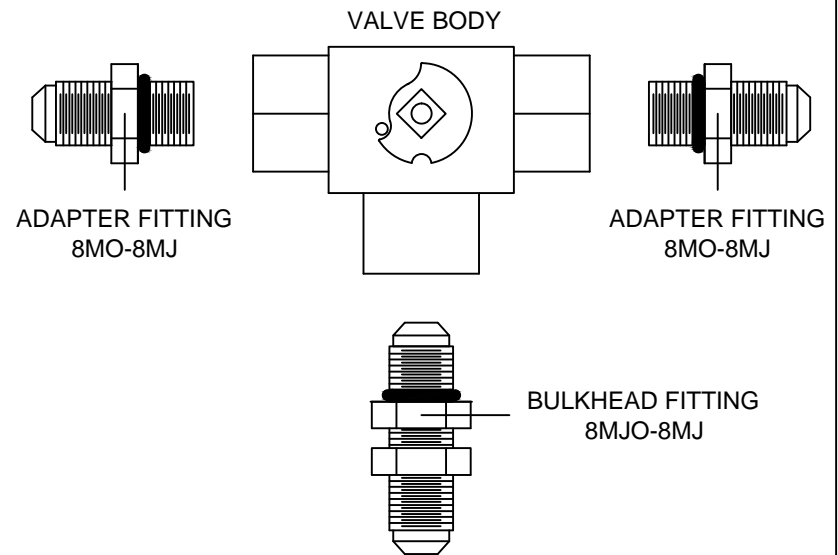
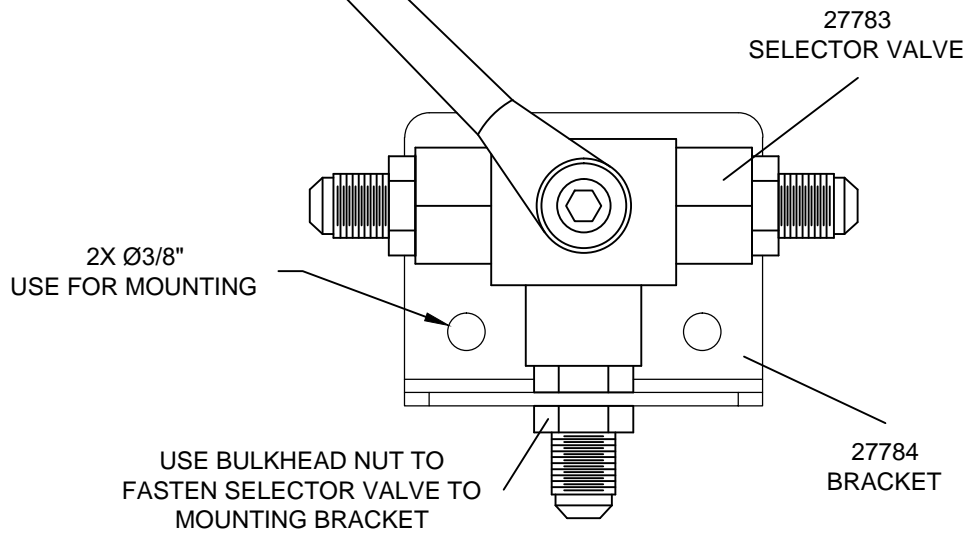
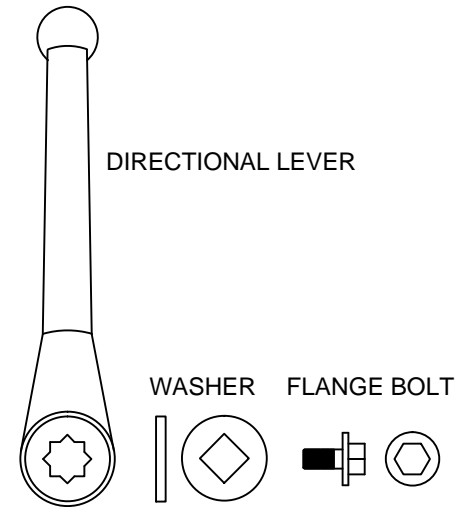
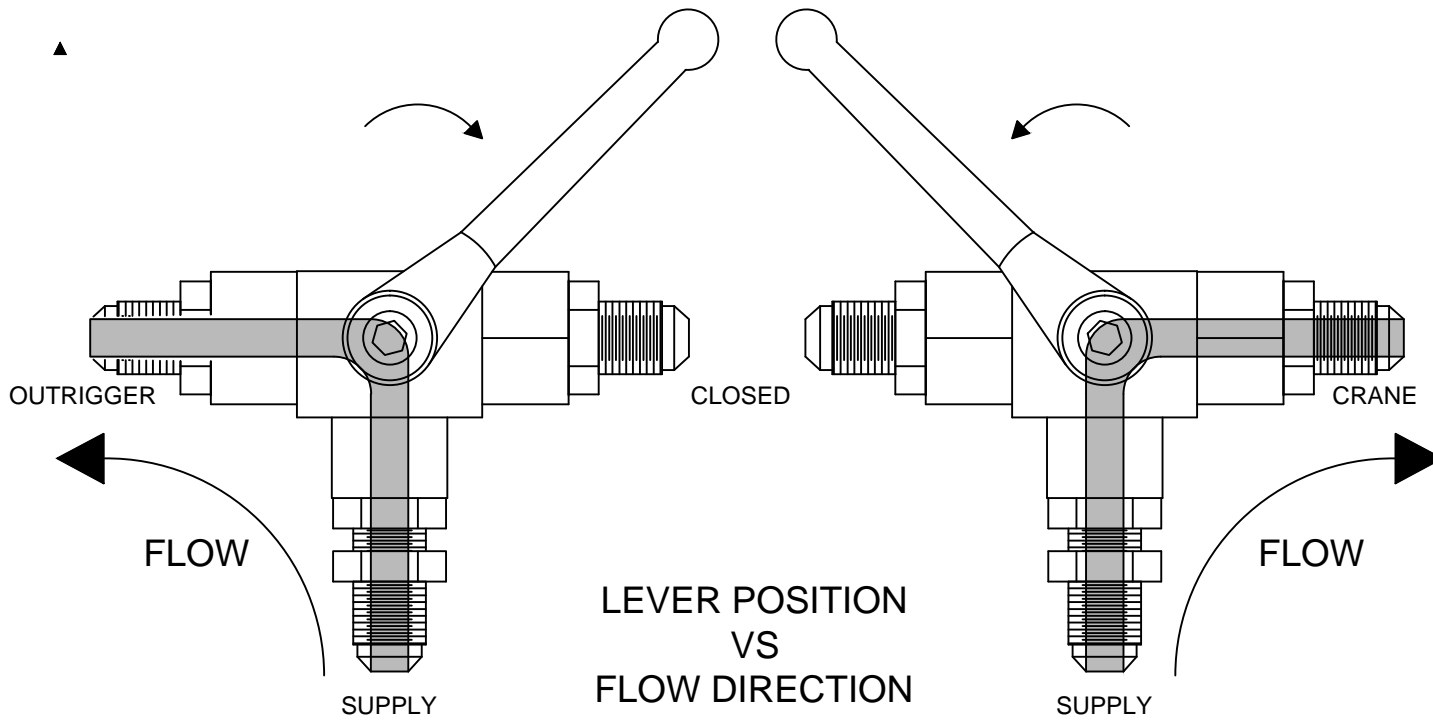

VENCO VENTURO INDUSTRIES LLC
CINCINNATI, OHIO

SELECTOR VALVE OVERVIEW

HYDRAULIC CRANES & STABILIZERS

DATE
12-07-23B

SUPERSEDES
01-20-17A

SECTION
C200

25447-1

RECOMMENDED DEPARTURE ANGLE



VENCO VENTURO INDUSTRIES LLC
CINCINNATI, OHIO

RECOMMENDED DEPARTURE ANGLE

REAR MOUNTED OUTRIGGERS

DATE
08-25-22A

SUPERSEDES
01-18-17

PAGE

-

25485

MOUNTING THE OUTRIGGER LEGS, 27000 SERIES OUTRIGGERS

FOLLOW INSTRUCTIONS FOR MOUNTING 27000 SERIES OUTRIGGER LEGS.

1. DETERMINE PLACEMENT OF OUTRIGGER LEGS. REFER TO MODEL SPECIFIC 'OVERALL DIMENSIONS' PAGE.
2. USE HARDWARE & FASTENERS PROVIDED:
 - [8] HEX HEAD CAP SCREW;
5/8-11 X 1-1/2", GR. 8, ZINC
 - [8] LOCK NUT;
5/8-11, GR. 8, ZINC, NYLON-INSERT
3. INSERT BOLTS POINTING AWAY FROM OUTRIGGER.
4. TORQUE OUTRIGGER LEG BOLTS & NUTS TO 190 FT-LBS EACH.
5. PLACE 24964 DANGER DECALS, [1] ON EACH LEG

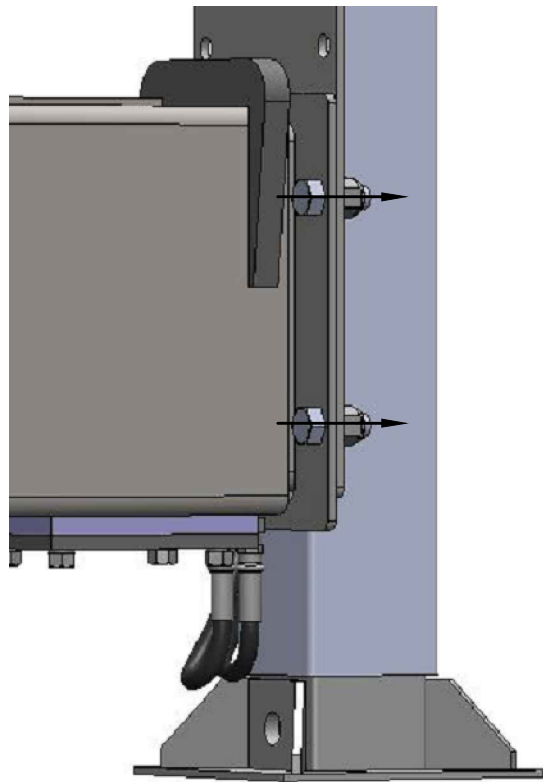

4 MOUNTING POSITIONS

6" MOUNTING RANGE

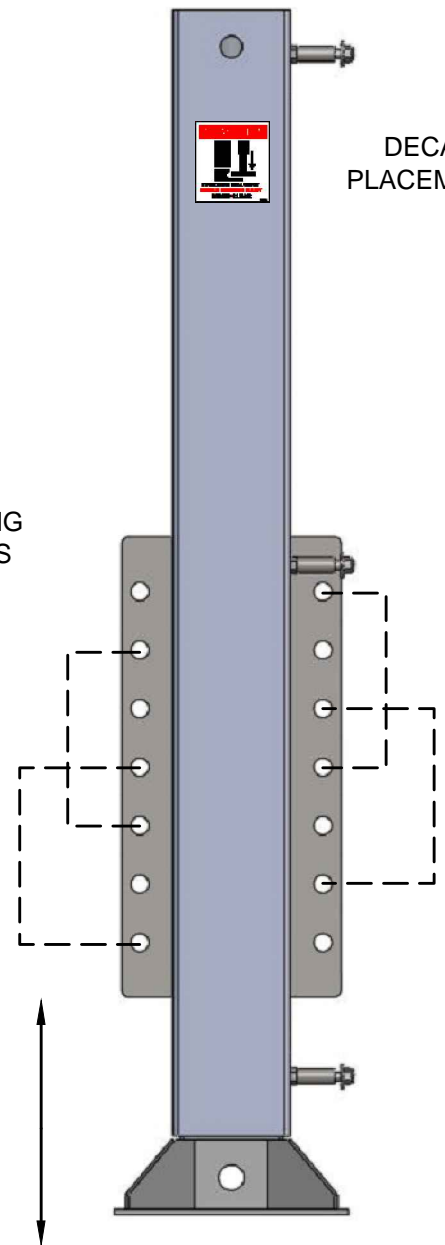

VENCO VENTURO INDUSTRIES LLC
CINCINNATI, OHIO

MOUNTING THE LEGS

27000 SERIES OUTRIGGERS

DATE
02-23-17

SUPERSEDES
-

PAGE

04

28201

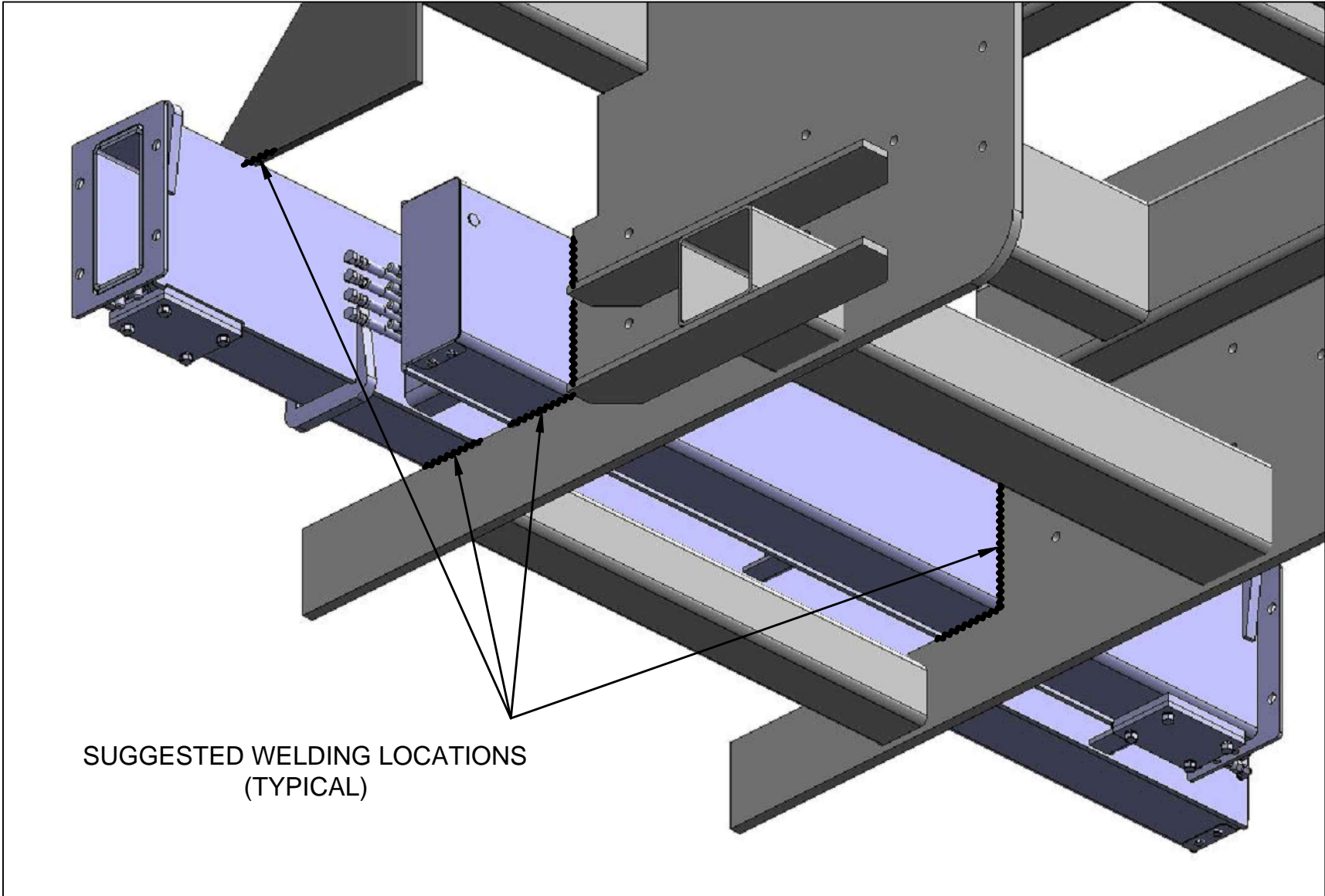

VENCO VENTURO INDUSTRIES LLC
CINCINNATI, OHIO

RECOMMENDED MOUNTING TO TRUCK FRAME

27634 & 27789 OUTRIGGERS

DATE
02-23-17

SUPERSEDES
-

PAGE

05

28202

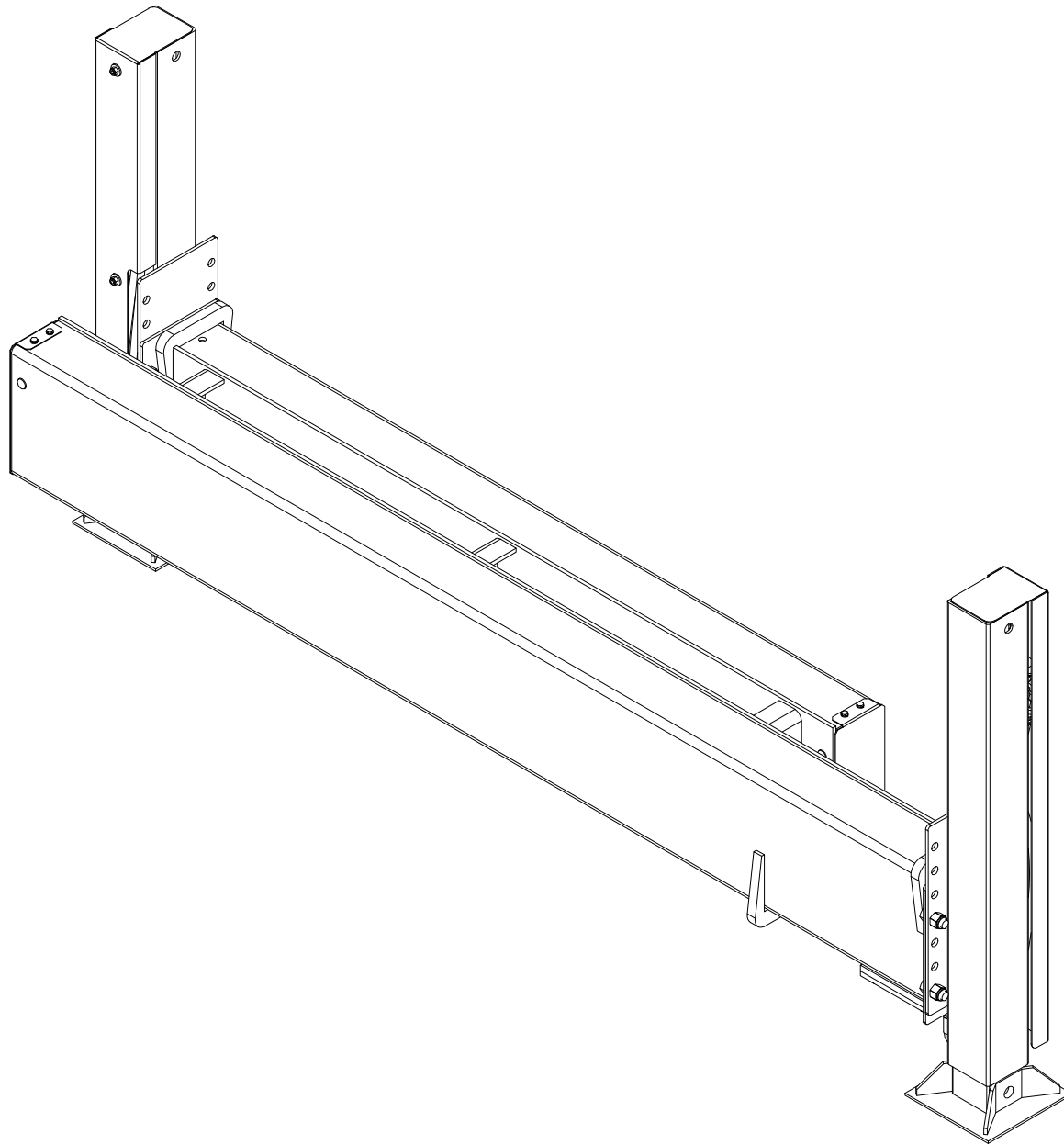

VENCO VENTURO INDUSTRIES LLC
CINCINNATI, OHIO

ISOMETRIC VIEW

27634 OUTRIGGER (WITH LONG LEGS)

DATE
02-23-17

SUPERSEDES
-

PAGE

06

28203

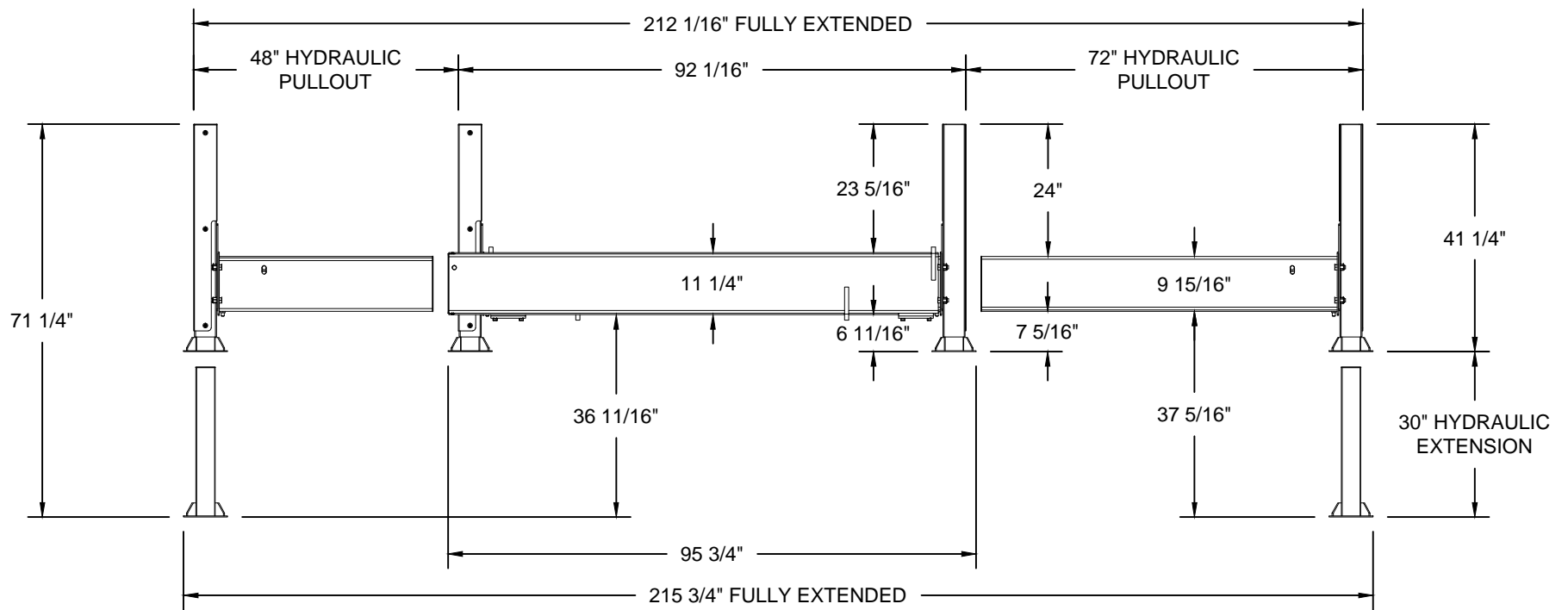
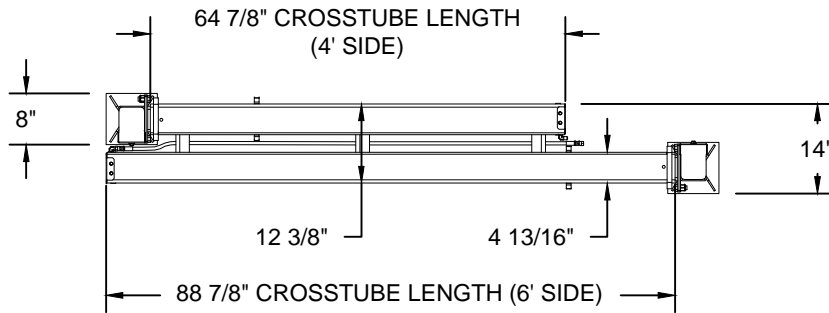

HIGHEST LEG MOUNT SHOWN

6" RANGE ADJUSTABLE
FOR LEG MOUNTING
AT 2" INCREMENTS



VENCO VENTURO INDUSTRIES LLC
CINCINNATI, OHIO

OVERALL DIMENSIONS

27634 OUTRIGGER WITH LONG LEGS

DATE
02-23-17

SUPERSEDES
-

PAGE

07

28204

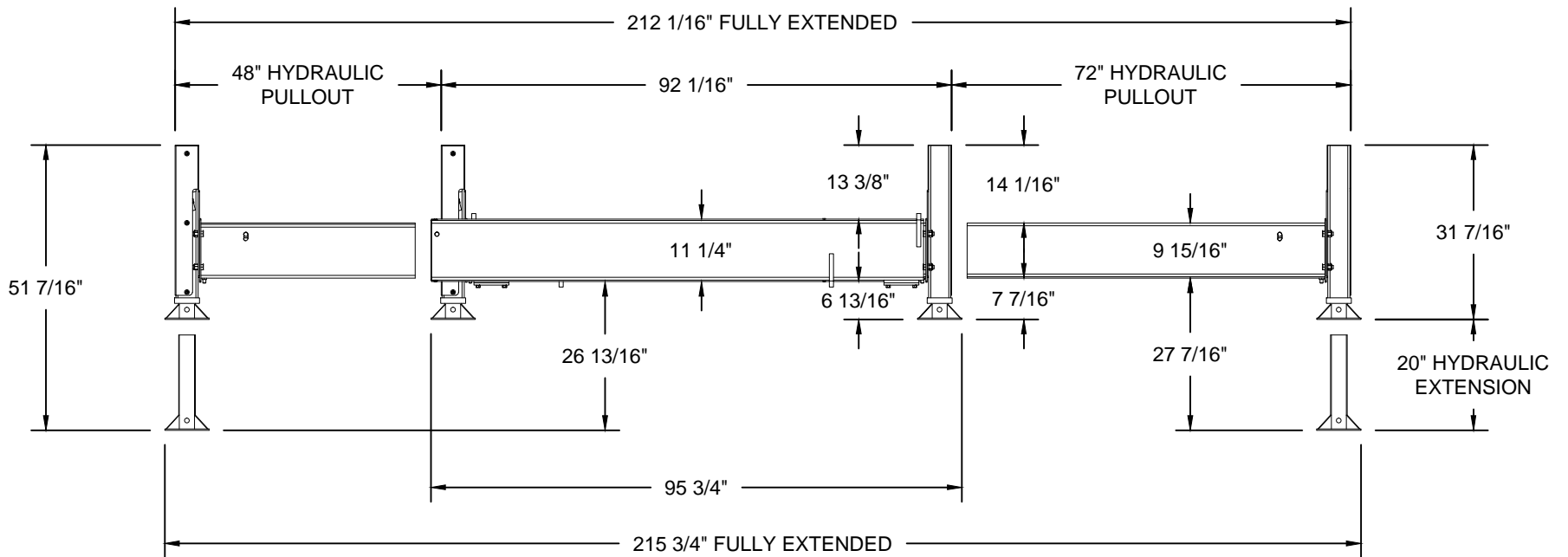
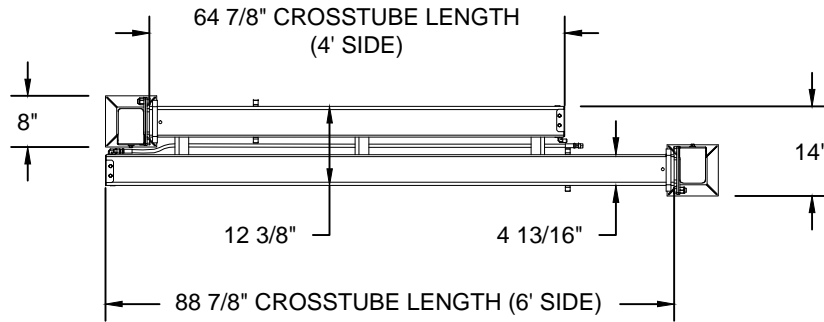

HIGHEST LEG MOUNT SHOWN

6" RANGE ADJUSTABLE
FOR LEG MOUNTING
AT 2" INCREMENTS



VENCO VENTURO INDUSTRIES LLC
CINCINNATI, OHIO

OVERALL DIMENSIONS

27634 OUTRIGGER WITH SHORT LEGS

DATE
02-23-17

SUPERSEDES
-

PAGE

08

28205

APPLICATION	6' SIDE	LEG FUNCTION	4' SIDE
LEG	A	DOWN	E
LEG	B	UP	F
PULLOUT	C	IN	G
PULLOUT	D	OUT	H

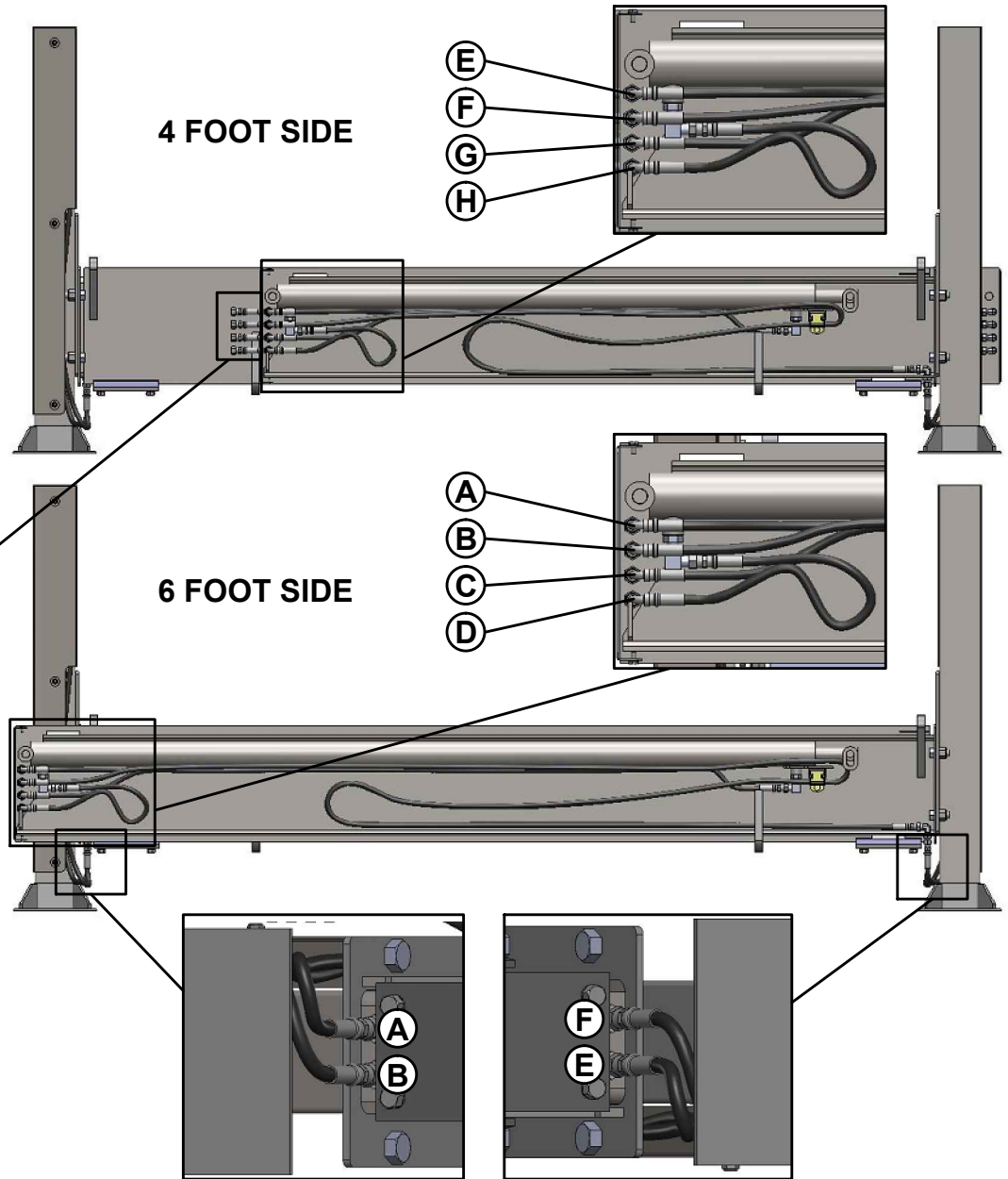
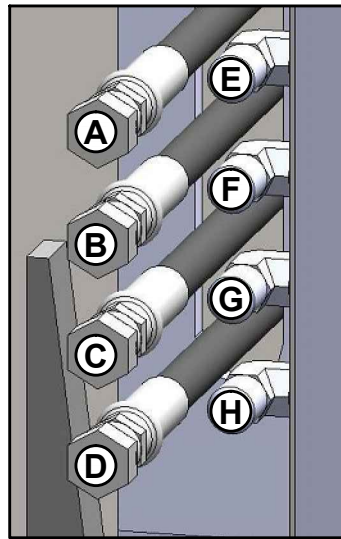
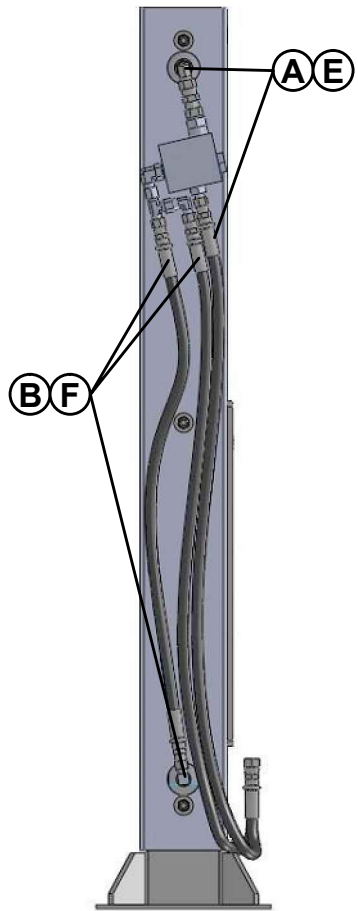

VENCO VENTURO INDUSTRIES LLC
CINCINNATI, OHIO

HYDRAULIC MAPPING, OUTRIGGER SIDE

27634 OUTRIGGER

DATE
02-23-17

SUPERSEDES
-

PAGE

09

28206

ASSEMBLY OF 27634 OUTRIGGER WITH LESS-CROSSTUBE CONFIGURATION

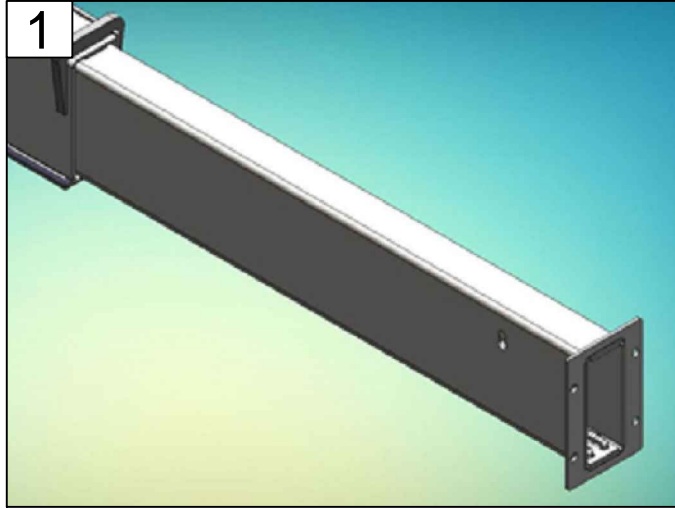

1
INSERT 4' & 6' PULLOUT ASSEMBLIES INTO CROSSTUBE
SEE STEP 2 BEFORE SLIDING TOGETHER



2
FASTEN BEARING PADS, SPACERS, & RETAINERS
PAGE 17 - ITEMS 2, 3, 4, 10, 11



3
FASTEN BULKHEAD FITTINGS, POINTING CURB-SIDE
PAGE 17 - ITEM 9

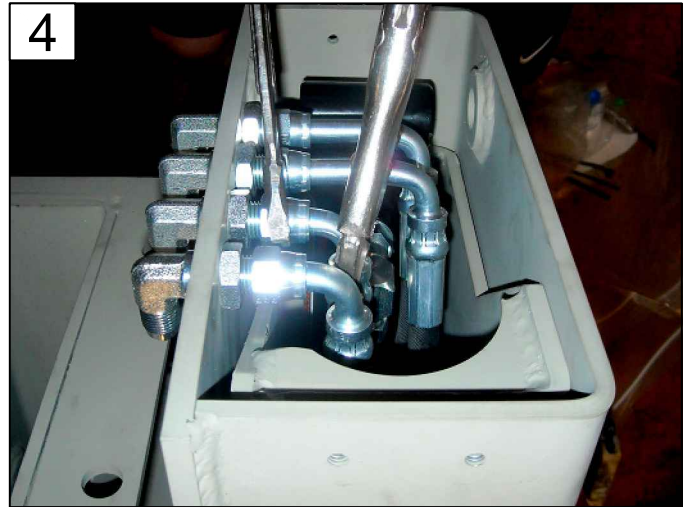

4
SEE HYDRAULIC MAPPING SECTION OF MANUAL
REFER TO 'LETTER' TAGS ATTACHED TO PULLOUT HOSES



5
FASTEN END CAP COVERS FLUSH AGAINST CROSSTUBES
PAGE 17 - ITEMS 5, 12, 13



6
PLUG WELD SHIMS PROVIDED TO REDUCE VERTICAL GAP
PAGE 17 - ITEM 6 OR 7



VENCO VENTURO INDUSTRIES LLC
CINCINNATI, OHIO

LESS-CROSSTUBE ASSY

27634 OUTRIGGER

DATE
02-23-17

SUPERSEDES
-

PAGE
10

28207

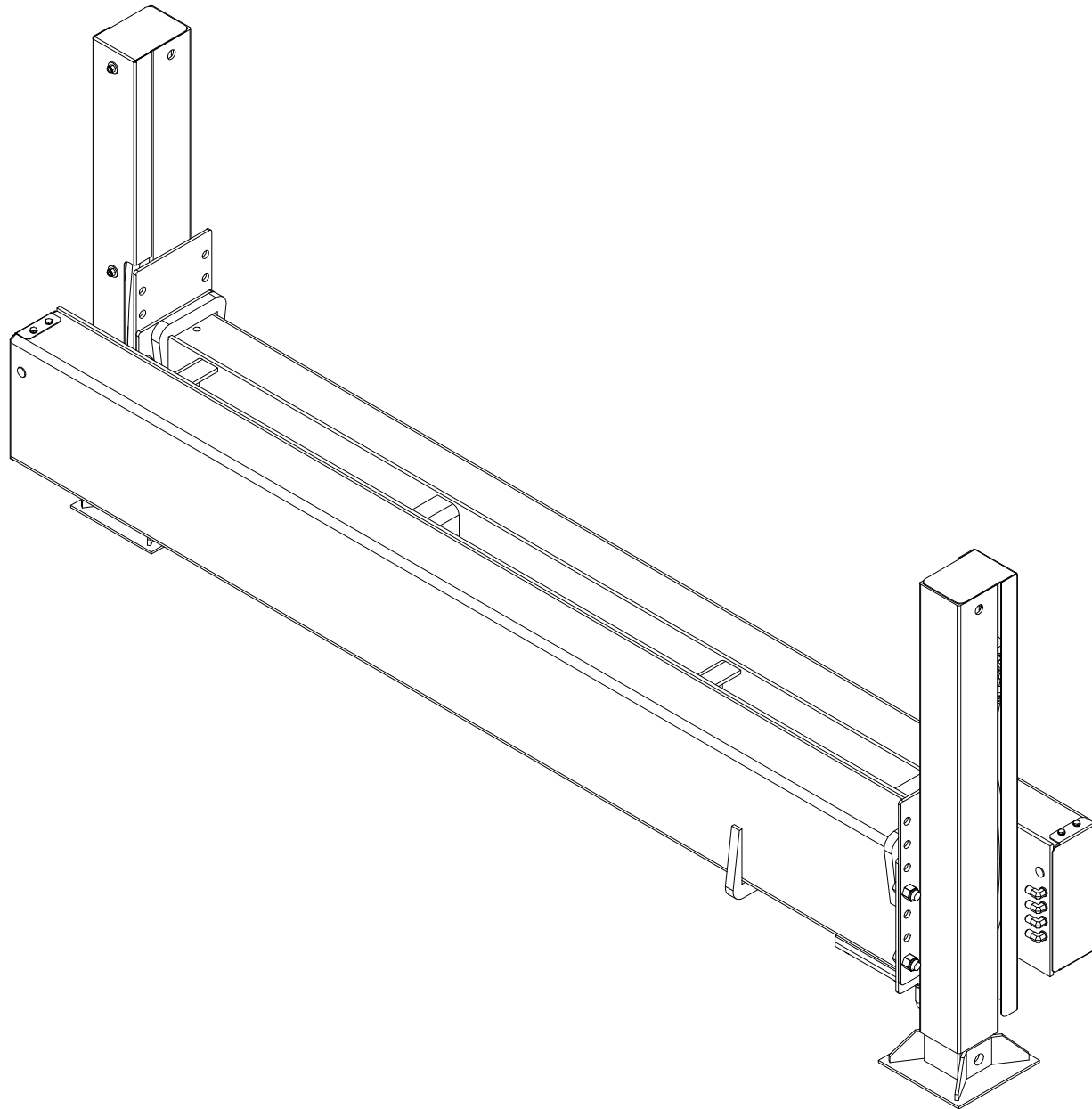

VENCO VENTURO INDUSTRIES LLC
CINCINNATI, OHIO

ISOMETRIC VIEW

27789 OUTRIGGER (WITH LONG LEGS)

DATE
02-23-17

SUPERSEDES
-

PAGE

11

28208

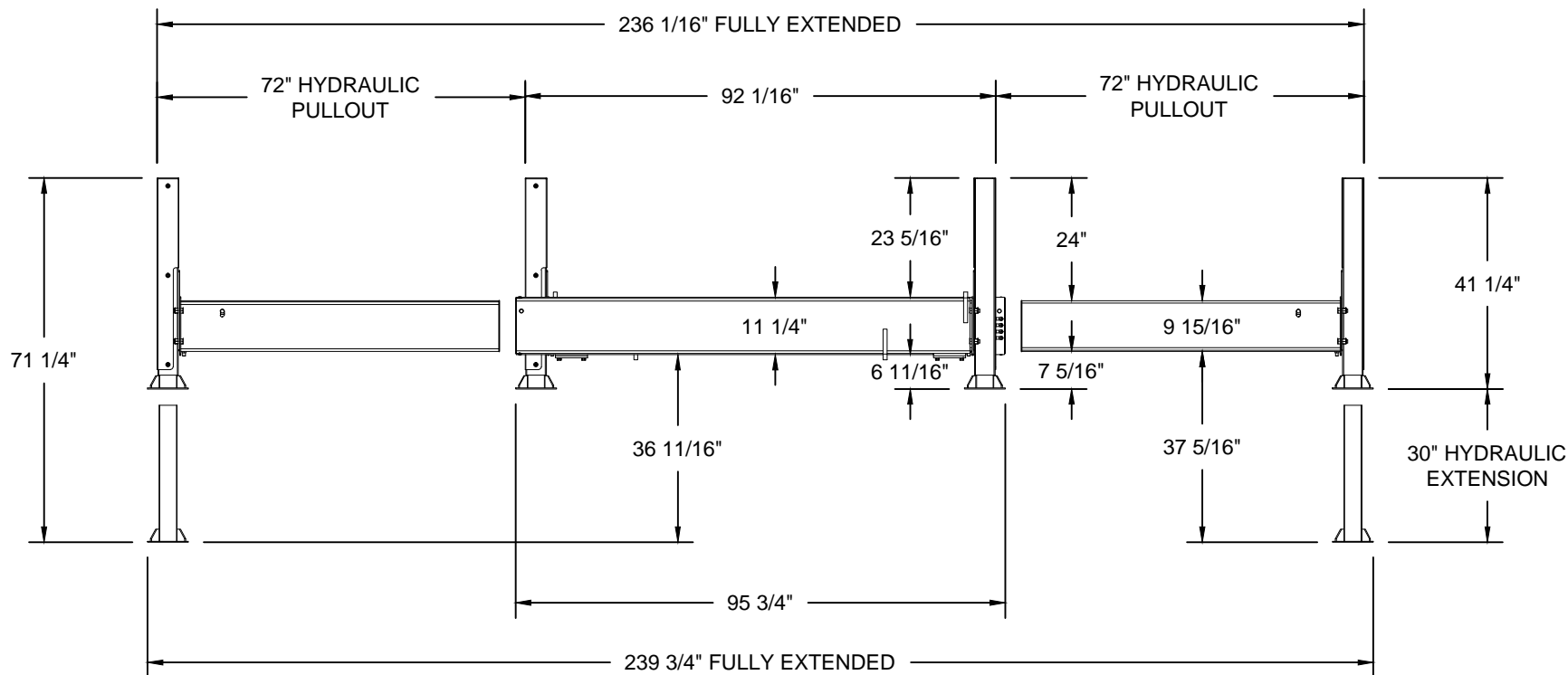
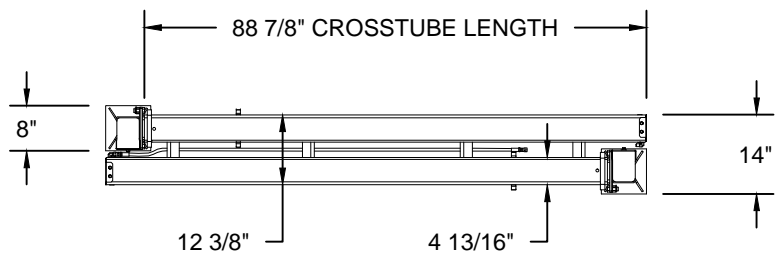

HIGHEST LEG MOUNT SHOWN

6" RANGE ADJUSTABLE FOR LEG MOUNTING AT 2" INCREMENTS



VENCO VENTURO INDUSTRIES LLC
CINCINNATI, OHIO

OVERALL DIMENSIONS

27789 OUTRIGGER WITH LONG LEGS

DATE
02-23-17

SUPERSEDES
-

PAGE

12

28209

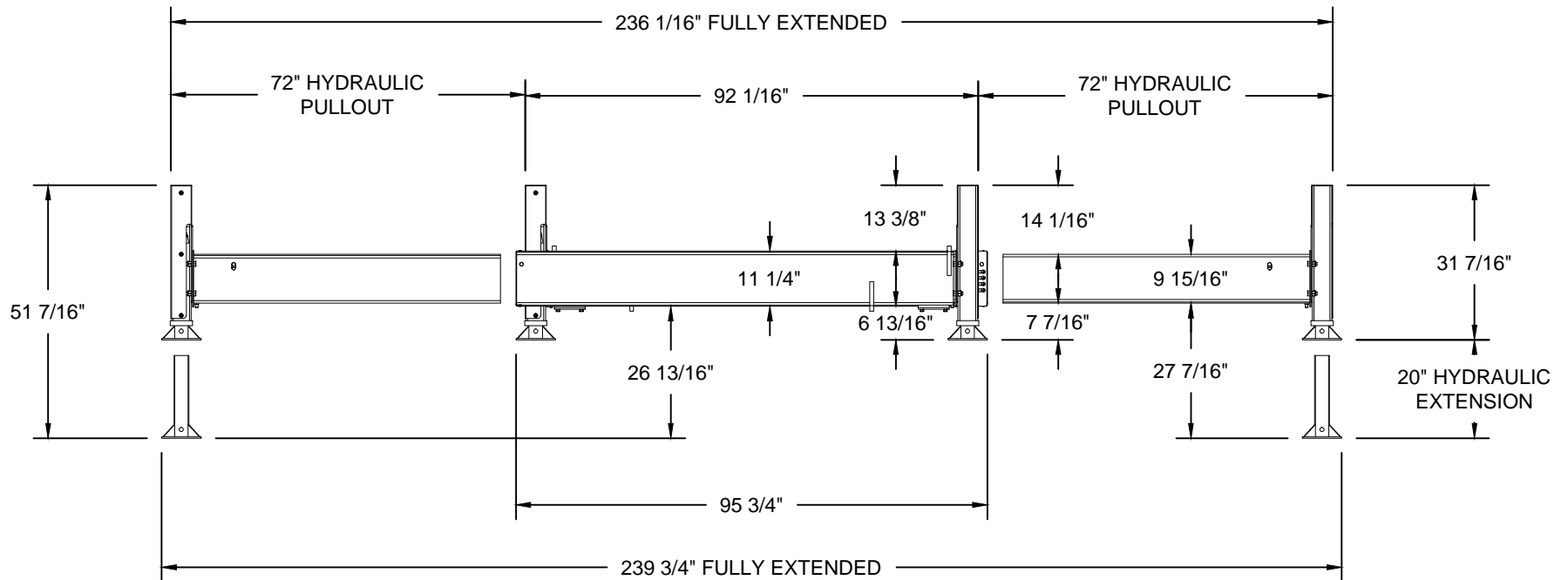
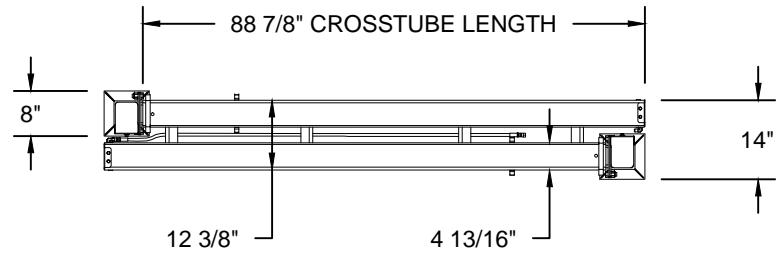

HIGHEST LEG MOUNT SHOWN

6" RANGE ADJUSTABLE
FOR LEG MOUNTING
AT 2" INCREMENTS



VENCO VENTURO INDUSTRIES LLC
CINCINNATI, OHIO

OVERALL DIMENSIONS

27789 OUTRIGGER WITH SHORT LEGS

DATE
02-23-17

SUPERSEDES
-

PAGE

13

28210

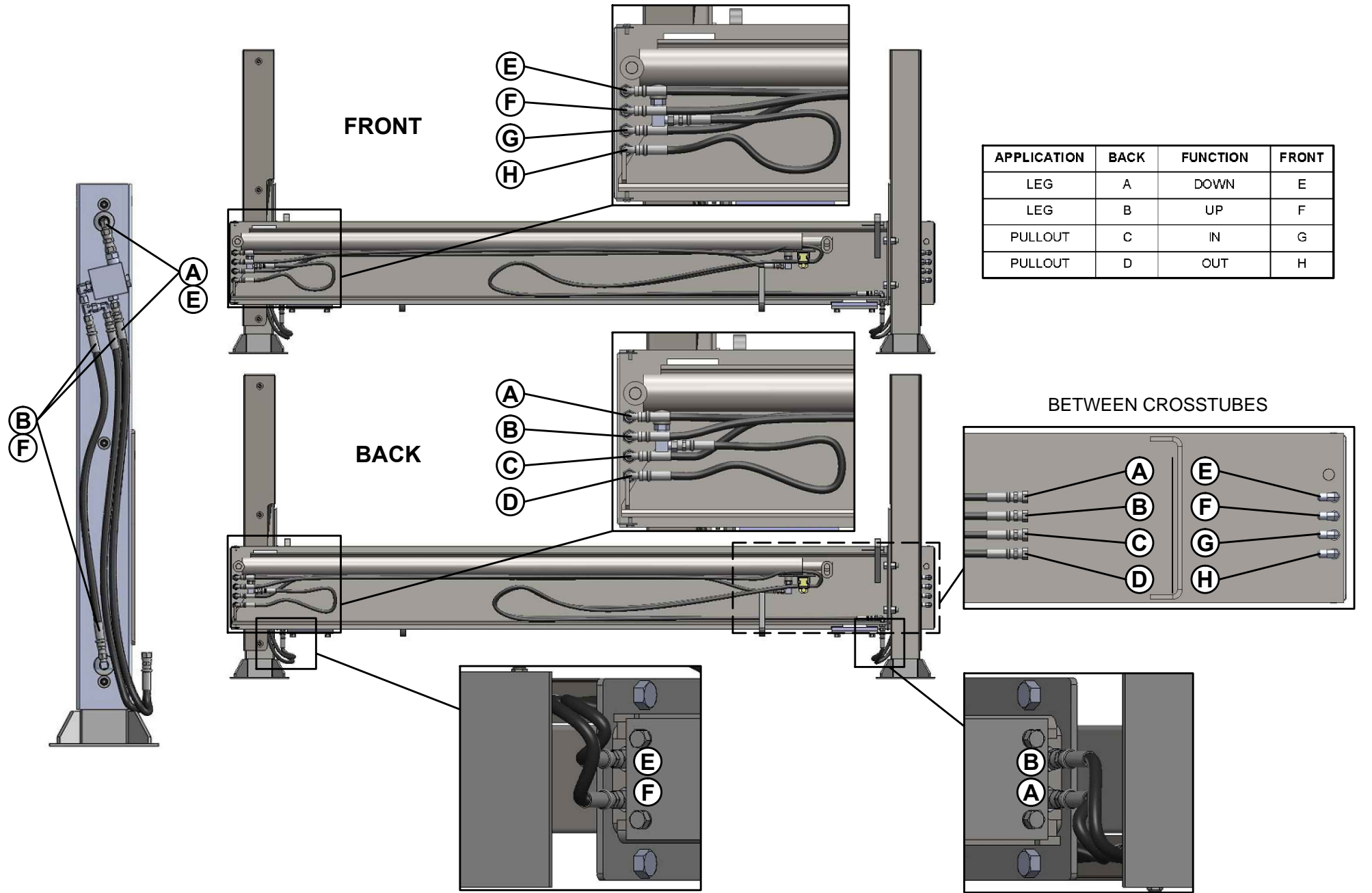

APPLICATION	BACK	FUNCTION	FRONT
LEG	A	DOWN	E
LEG	B	UP	F
PULLOUT	C	IN	G
PULLOUT	D	OUT	H

BETWEEN CROSSTUBS

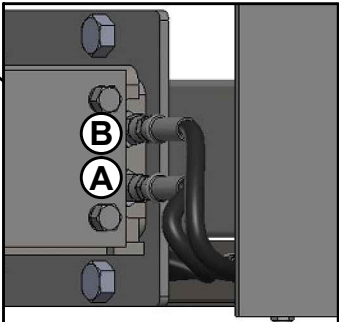
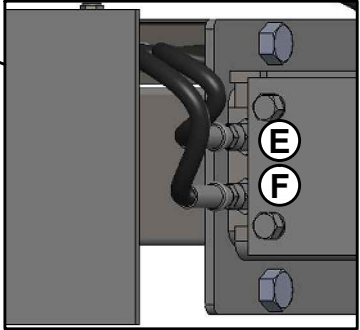
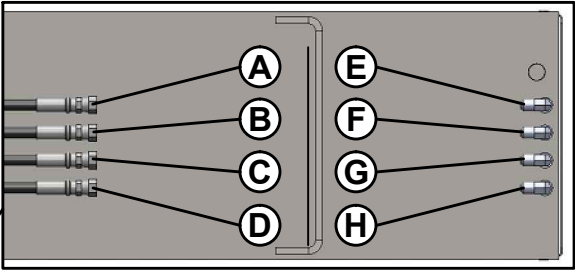

VENCO VENTURO INDUSTRIES LLC
CINCINNATI, OHIO

HYDRAULIC MAPPING, OUTRIGGER SIDE

27789 OUTRIGGER

DATE
02-23-17

SUPERSEDES
-

PAGE

14

28211

FUNCTIONS		
A	DOWN	RIGHT LEG
B	UP	
C	IN	RIGHT PULLOUT
D	OUT	
E	DOWN	LEFT LEG
F	UP	
G	IN	LEFT PULLOUT
H	OUT	
P	PRESSURE	TANK OR SUPPLY
T	RETURN	

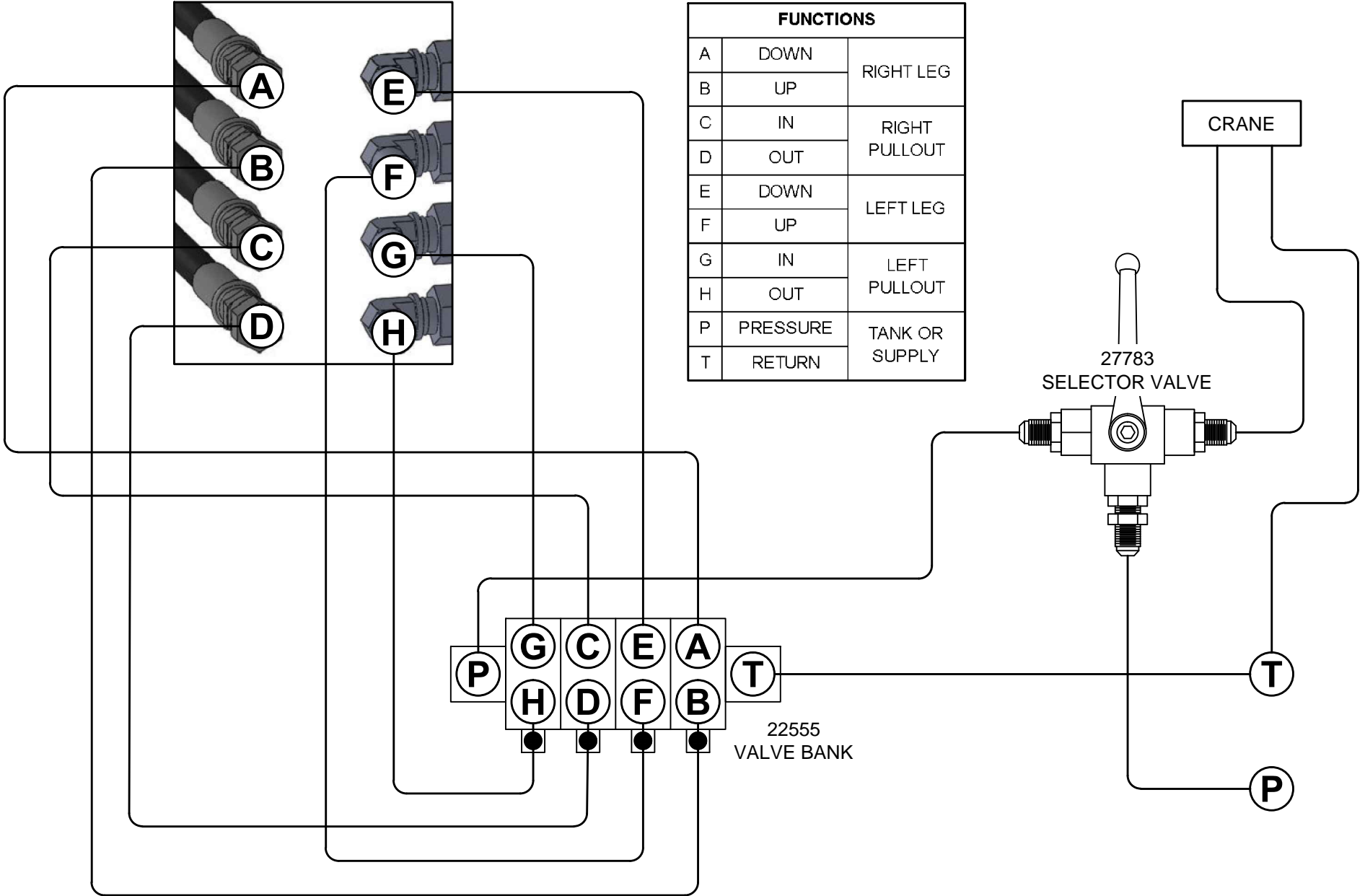

VENCO VENTURO INDUSTRIES LLC
CINCINNATI, OHIO

HYDRAULIC MAPPING, COMPARTMENT SIDE

27634 & 27789 PHX OUTRIGGERS

DATE
02-23-17

SUPERSEDES
-

PAGE
15

28212

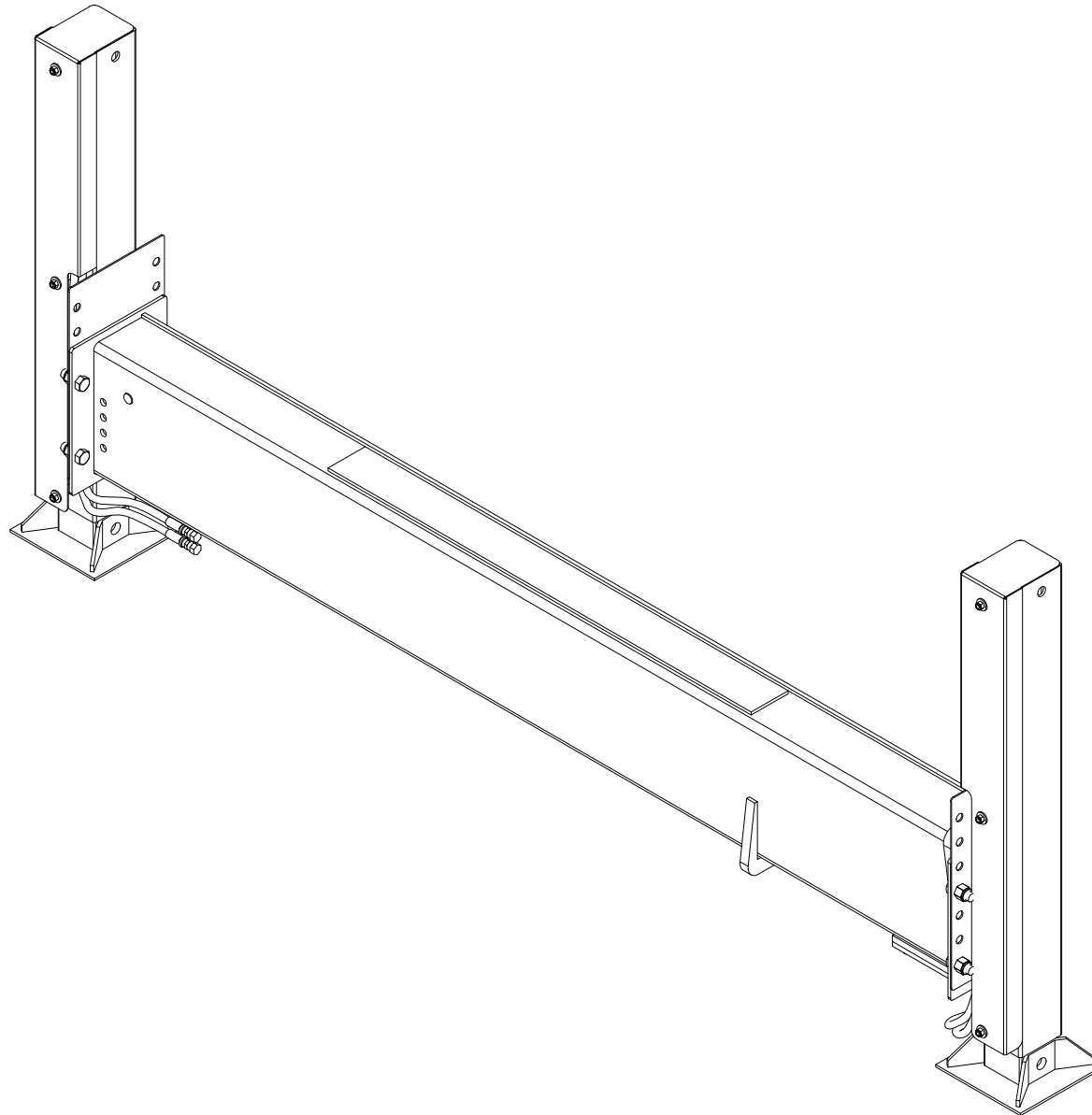

VENCO VENTURO INDUSTRIES LLC
CINCINNATI, OHIO

ISOMETRIC VIEW

27695 OUTRIGGER (WITH LONG LEGS)

DATE
02-23-17

SUPERSEDES
-

PAGE

25

28222

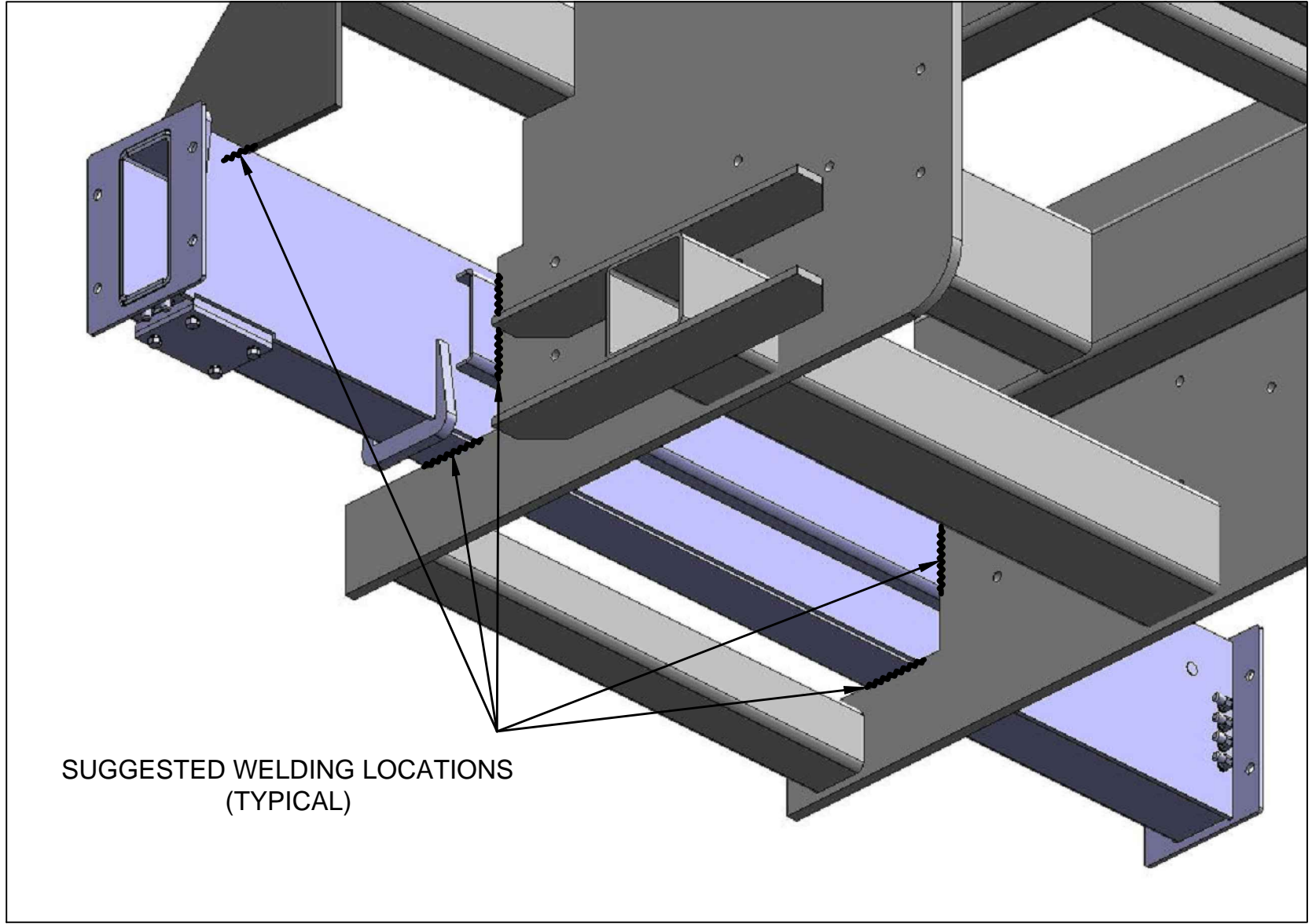

SUGGESTED WELDING LOCATIONS
(TYPICAL)



VENCO VENTURO INDUSTRIES LLC
CINCINNATI, OHIO

RECOMMENDED MOUNTING TO TRUCK FRAME

27695 OUTRIGGER

DATE
02-23-17

SUPERSEDES
-

PAGE

26

28223

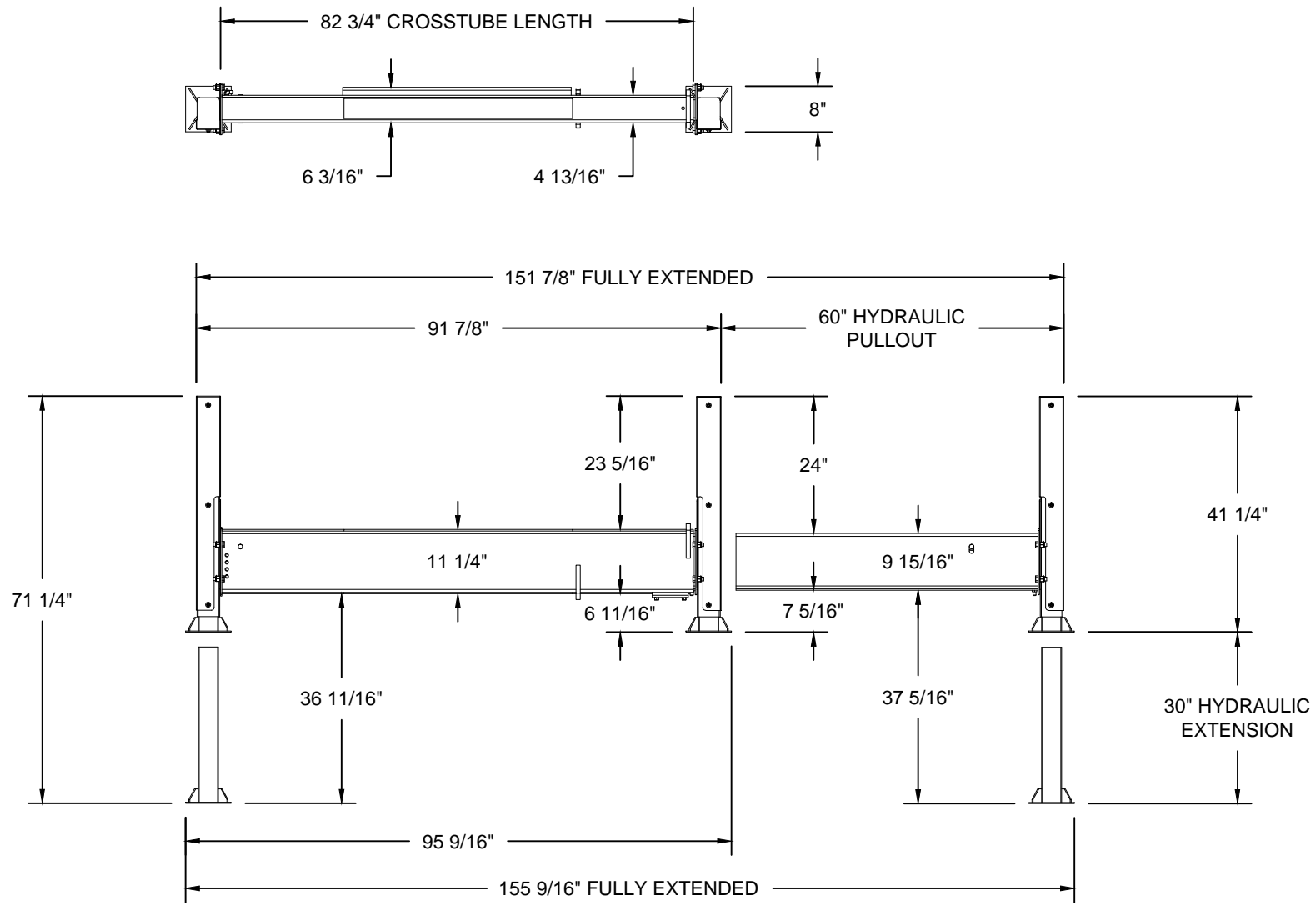

HIGHEST LEG MOUNT SHOWN

6" RANGE ADJUSTABLE
FOR LEG MOUNTING
AT 2" INCREMENTS



VENCO VENTURO INDUSTRIES LLC
CINCINNATI, OHIO

OVERALL DIMENSIONS

27695 OUTRIGGER WITH LONG LEGS

DATE
02-23-17

SUPERSEDES
-

PAGE

27

28224

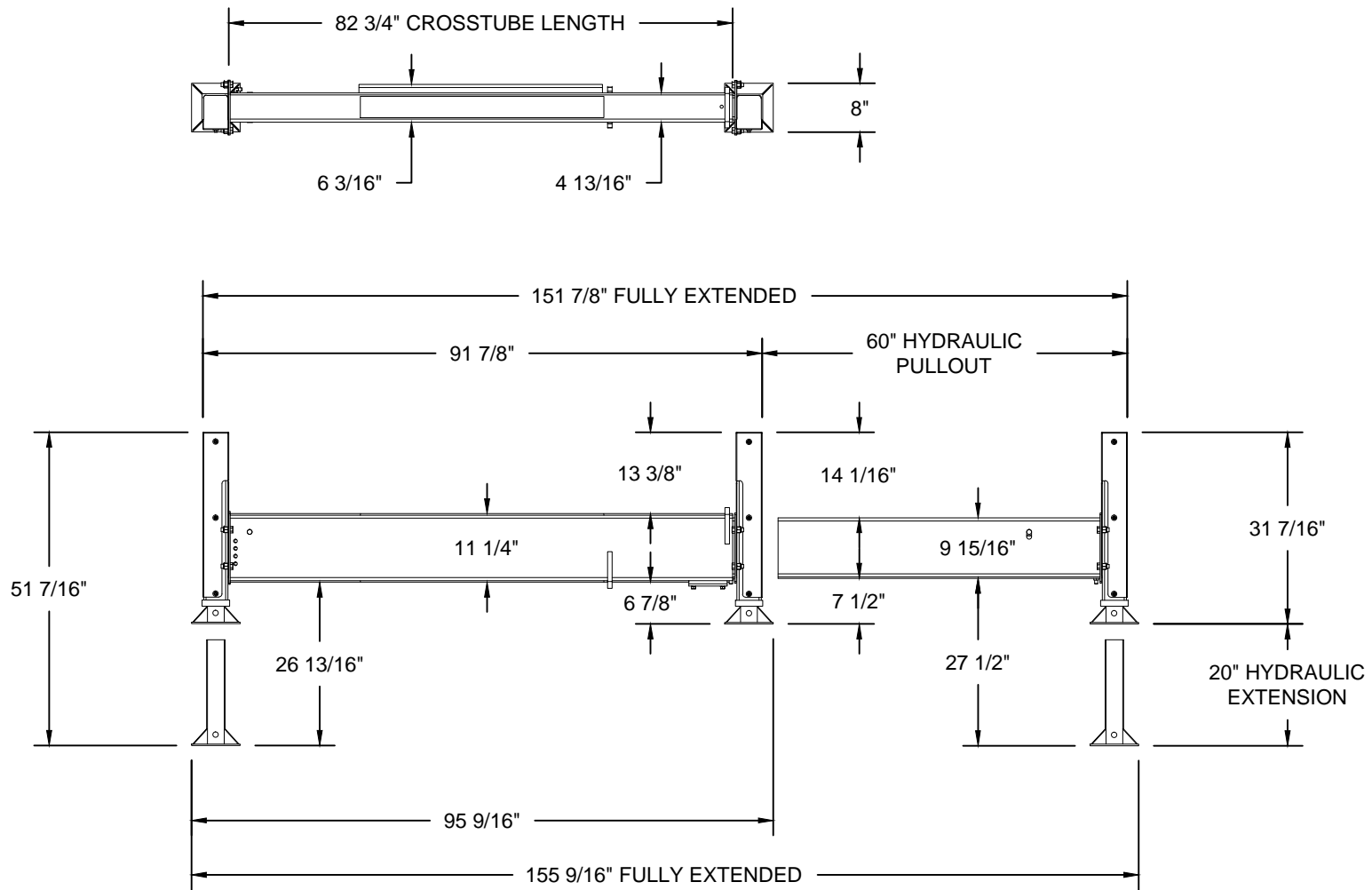

HIGHEST LEG MOUNT SHOWN

6" RANGE ADJUSTABLE
FOR LEG MOUNTING
AT 2" INCREMENTS



VENCO VENTURO INDUSTRIES LLC
CINCINNATI, OHIO

OVERALL DIMENSIONS

27695 OUTRIGGER WITH SHORT LEGS

DATE
02-23-17

SUPERSEDES
-

PAGE

28

28225

FUNCTIONS		
A	DOWN	RT LEG
B	UP	RT LEG
C	OUT	PULLOUT
D	IN	PULLOUT
E	DOWN	LT LEG
F	UP	LT LEG

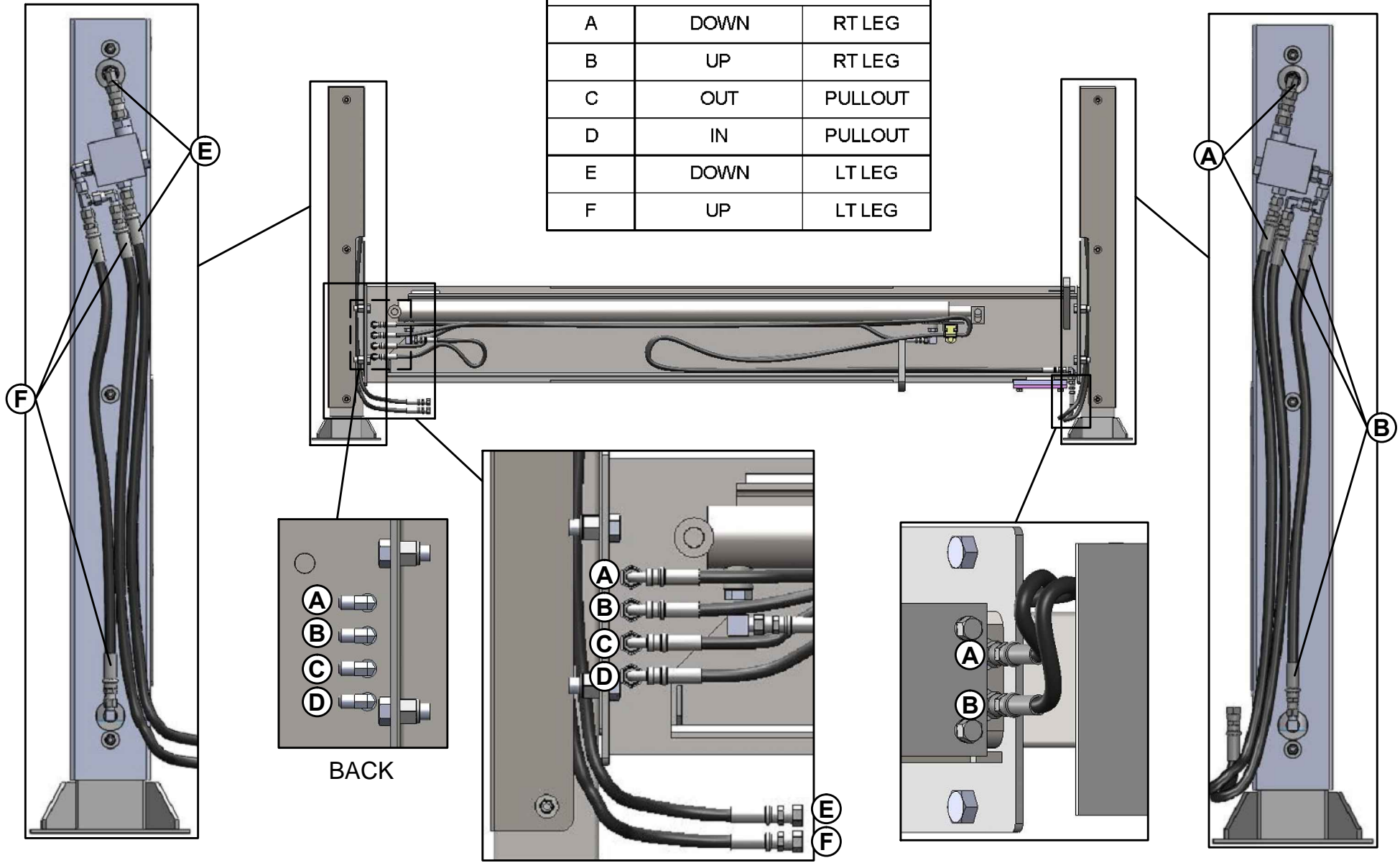

VENCO VENTURO INDUSTRIES LLC
CINCINNATI, OHIO

HYDRAULIC MAPPING, OUTRIGGER SIDE

27695 OUTRIGGER

DATE
02-23-17

SUPERSEDES
-

PAGE

29

28226

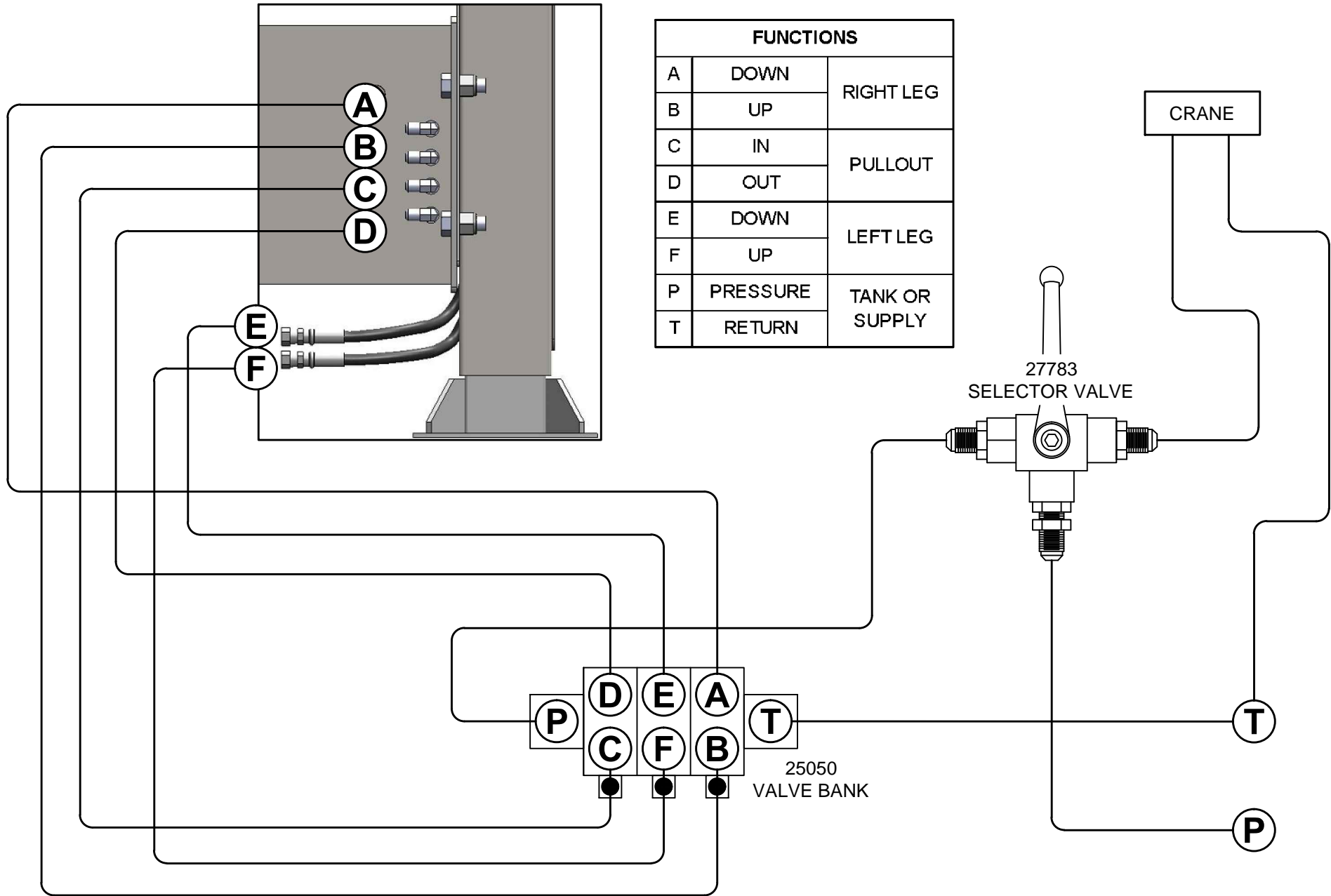

FUNCTIONS		
A	DOWN	RIGHT LEG
B	UP	
C	IN	PULLOUT
D	OUT	
E	DOWN	LEFT LEG
F	UP	
P	PRESSURE	TANK OR SUPPLY
T	RETURN	



VENCO VENTURO INDUSTRIES LLC
CINCINNATI, OHIO

HYDRAULIC MAPPING, COMPARTMENT SIDE

27695 OUTRIGGER

DATE
02-23-17

SUPERSEDES
-

PAGE

30

28227

SECTION 400

REPLACEMENT PARTS



VENCO VENTURO INDUSTRIES LLC
CINCINNATI, OHIO

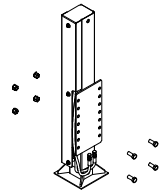

LEFT LEG
(LONG)

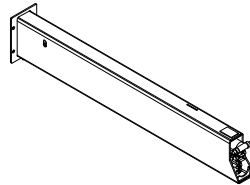

LEFT PULLOUT
(4 FOOT)

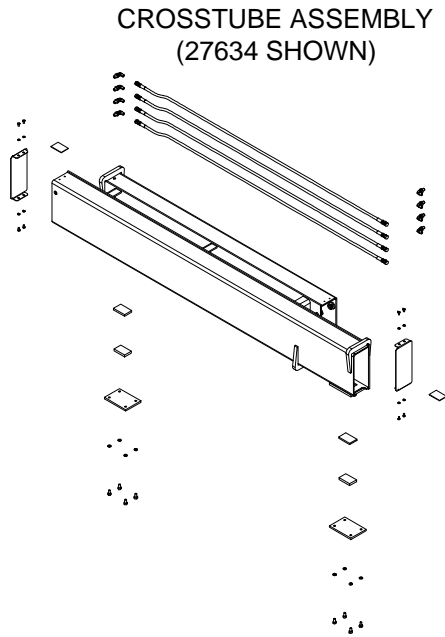

CROSTUBE ASSEMBLY
(27634 SHOWN)

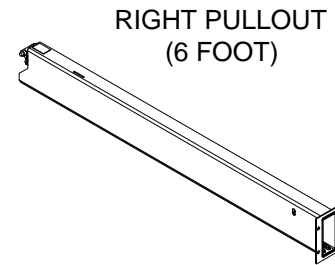

RIGHT PULLOUT
(6 FOOT)

RIGHT LEG
(LONG)

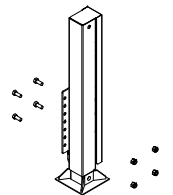

VENCO VENTURO INDUSTRIES LLC
CINCINNATI, OHIO

PARTS BREAKDOWN, SECTIONS

27634 & 27789 OUTRIGGERS

DATE
02-23-17

SUPERSEDES
-

PAGE

16

28213

PARTS BREAKDOWN, CROSSTUBE ASSEMBLY, 27634 & 27789 OUTRIGGERS

27634 & 27789 OUTRIGGERS CROSSTUBE ASSEMBLY			
#	DESCRIPTION	QTY	PART #
1	CROSSTUBE; DUAL-TUBE, 27000 SERIES	1	27631 / 27788
2	BEARING PAD; 3 1/8" X 3 1/2" X 3/8", UHMW	2	27718
3	BEARING SPACER; 3 1/8" X 2" X 1/2", CROSSTUBE	2	27719
4	PLATE; BEARING RETAINER, 27000 SERIES O.R.'S	2	27643
5	COVER; END CAP, DUAL CROSSTUBE, 27000 SERIES	2	27644
6	SHIM; VERTICAL GAP, 10 GA, 27000 SERIES O.R.'S	0-2	27631J
7	SHIM; VERTICAL GAP, 14 GA, 27000 SERIES O.R.'S	0-2	27631K
8	HOSE ASS'Y; 73" LONG, O.R. TO COMPARTMENT	4	27680
9	FITTING; BULKHEAD, ELBOW, 90°, 6MJ-6MJ	8	H2701LN-0606
10	HEX HEAD CAP SCREW; 3/8-16 X 3/4", GR. 5, ZINC	8	IHHCS03816075-5
11	LOCK WASHER; 3/8", GR. 5, ZINC	8	ILWSH-038
12	HEX HEAD CAP SCREW; 1/4-20 X 1/2", STAINLESS	8	IHHCS02520050S
13	LOCK WASHER; 1/4", STAINLESS	8	ILWSH-025S

REFERENCE PAGE 18



VENCO VENTURO INDUSTRIES LLC
CINCINNATI, OHIO

PARTS BREAKDOWN

DATE
02-23-17

PAGE
17

CROSSTUBE ASSEMBLY

SUPERSEDES
-

28214

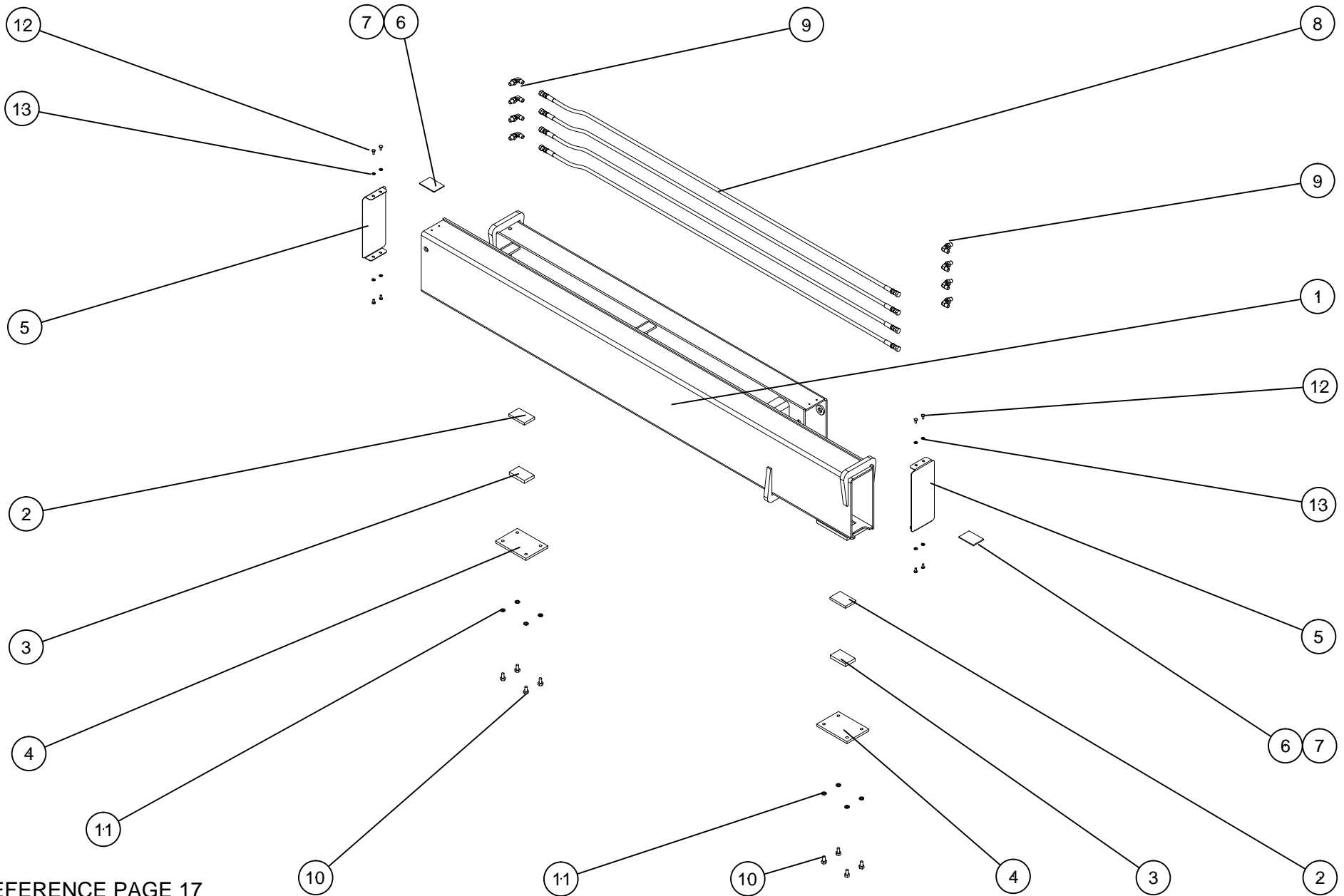

REFERENCE PAGE 17



VENCO VENTURO INDUSTRIES LLC
CINCINNATI, OHIO

PARTS BREAKDOWN, CROSSTUBE ASSEMBLY

27634 & 27789 OUTRIGGERS

DATE
02-23-17

SUPERSEDES
-

PAGE

18

28215

PARTS BREAKDOWN, 6' PULLOUT ASSEMBLY, 27634 & 27789 OUTRIGGERS

27634 & 27789 OUTRIGGERS 6' PULLOUT ASSEMBLY			
#	DESCRIPTION	QTY	PART #
1	PULLOUT TUBE; 6' SIDE, 27000 SERIES O.R.'S	1	27632
2	EXTENSION CYLINDER; 72" STROKE, 2" BORE	1	27635
3	BEARING PAD; 3 1/8" X 3 1/2" X 3/8", UHMW	1	27718
4	SHAFT; INBOARD, EXT. CYL., CROSSTUBE	1	27638
5	SHAFT; OUTBOARD, EXT. CYL., PULLOUT	1	27639
6	SET COLLAR; 3/4" I.D., 1 1/4" O.D.	4	00210
7	BUSHING; 14 GA, 3/4" I.D., 1 1/4" O.D., ZINC	2	12534-14
8	BUSHING; 10 GA, 3/4" I.D., 1 1/4" O.D., ZINC	4	12534-1
9	CLAMP SUPPORT; HOSE CLAMP, CYL. MOUNT	1	27689
10	HOSE CLAMP; ADJUSTABLE, GROMMET	2	27700
11	HOSE ASS'Y; CROSSOVER, UP & DOWN	2	27679
12	HOSE ASS'Y; RETRACTION, CYLINDER	1	27677
13	HOSE ASS'Y; EXTENSION, CYLINDER	1	27675
14	FITTING; ADAPTER, ELBOW, 90°, 6MJ-6MO	2	H6801L-0606
15	FITTING; BULKHEAD, ELBOW, 90°, 6MJ-6MJ	2	H2701LN-0606

REFERENCE PAGE 20



VENCO VENTURO INDUSTRIES LLC
CINCINNATI, OHIO

PARTS BREAKDOWN

6' PULLOUT ASSEMBLY

DATE
02-23-17

SUPERSEDES
-

PAGE
19

28216

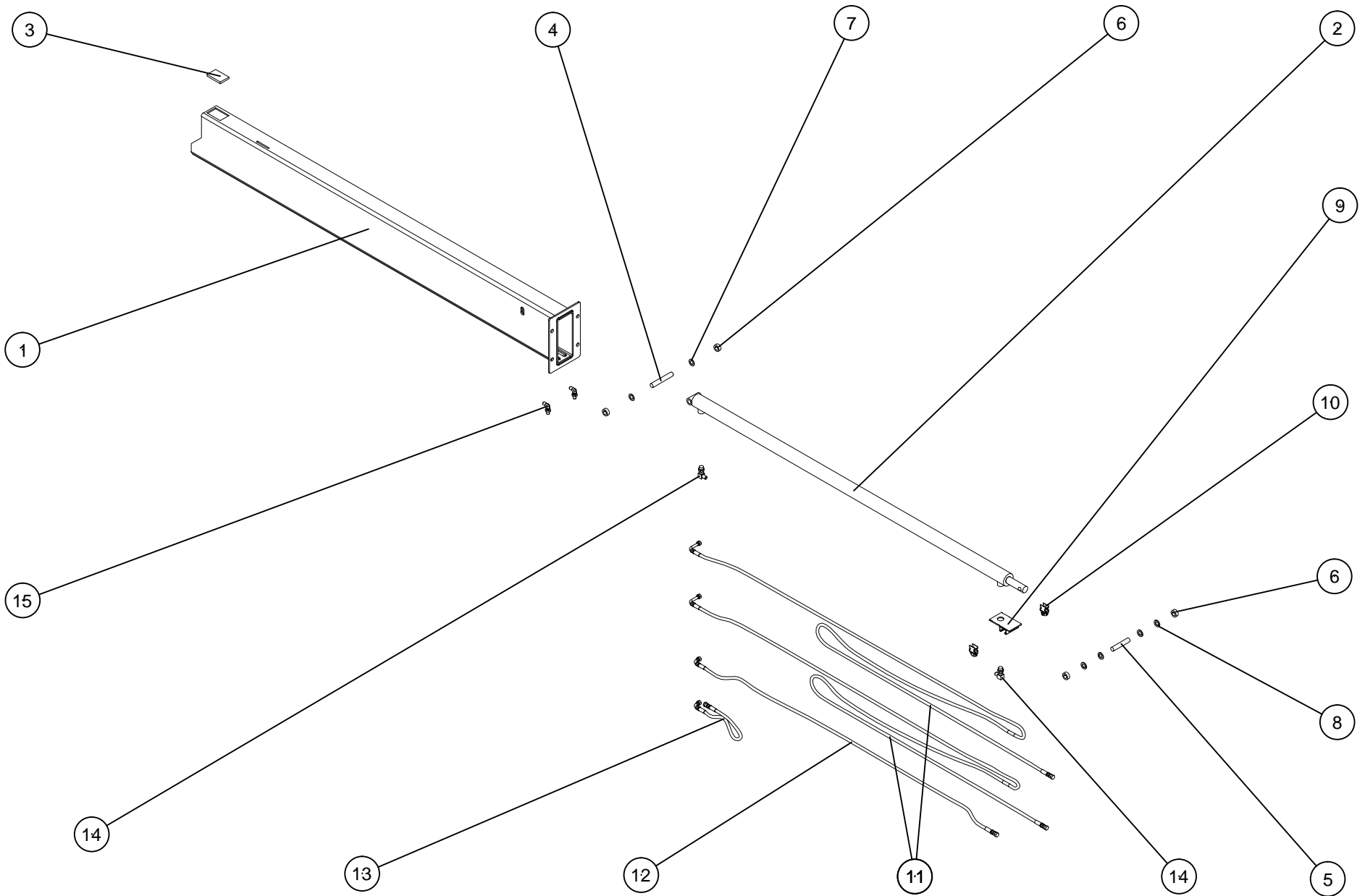

REFERENCE PAGE 19



VENCO VENTURO INDUSTRIES LLC
CINCINNATI, OHIO

PARTS BREAKDOWN, 6' PULLOUT ASSEMBLY

27634 & 27789 OUTRIGGERS

DATE
02-23-17

SUPERSEDES
-

PAGE

20

28217

PARTS BREAKDOWN, 4' PULLOUT ASSEMBLY, 27634 OUTRIGGERS

27634 OUTRIGGERS 4' PULLOUT ASSEMBLY			
#	DESCRIPTION	QTY	PART #
1	PULLOUT TUBE; 4' SIDE, 27000 SERIES O.R.'S	1	27633
2	EXTENSION CYLINDER; 48" STROKE, 2" BORE	1	25086
3	BEARING PAD; 3 1/8" X 3 1/2" X 3/8", UHMW	1	27718
4	SHAFT; INBOARD, EXT. CYL., CROSSTUBE	1	27638
5	SHAFT; OUTBOARD, EXT. CYL., PULLOUT	1	27639
6	SET COLLAR; 3/4" I.D., 1 1/4" O.D.	4	00210
7	BUSHING; 14 GA, 3/4" I.D., 1 1/4" O.D., ZINC	2	12534-14
8	BUSHING; 10 GA, 3/4" I.D., 1 1/4" O.D., ZINC	4	12534-1
9	CLAMP SUPPORT; HOSE CLAMP, CYL. MOUNT	1	27689
10	HOSE CLAMP; ADJUSTABLE, GROMMET	2	27700
11	HOSE ASS'Y; CROSSOVER, UP & DOWN	2	27678
12	HOSE ASS'Y; RETRACTION, CYLINDER	1	27676
13	HOSE ASS'Y; EXTENSION, CYLINDER	1	27675
14	FITTING; ADAPTER, ELBOW, 90°, 6MJ-6MO	2	H6801L-0606
15	FITTING; BULKHEAD, ELBOW, 90°, 6MJ-6MJ	2	H2701LN-0606

REFERENCE PAGE 22



VENCO VENTURO INDUSTRIES LLC
CINCINNATI, OHIO

PARTS BREAKDOWN

4' PULLOUT ASSEMBLY

DATE
01-15-25A

SUPERSEDES
02-23-17

PAGE

21

28218

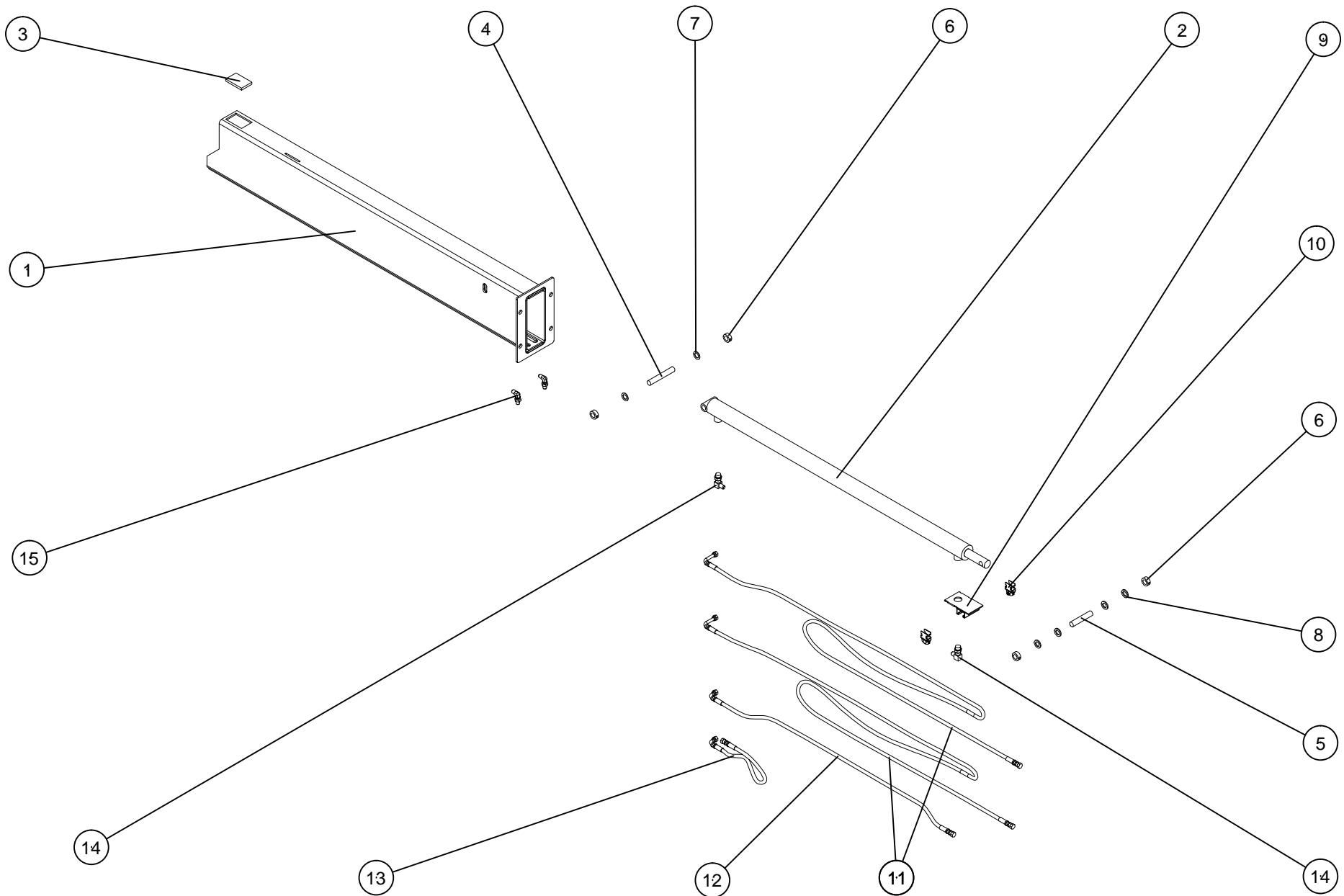

REFERENCE PAGE 21



VENCO VENTURO INDUSTRIES LLC
CINCINNATI, OHIO

PARTS BREAKDOWN, 4' PULLOUT ASSEMBLY

27634 OUTRIGGERS

DATE
02-23-17

SUPERSEDES
-

PAGE

22

28219

PARTS BREAKDOWN, HYDRAULIC LEGS, 27634 & 27789 OUTRIGGERS

27634 & 27789 OUTRIGGERS HYDRAULIC LEG ASSEMBLIES		LONG LEGS	SHORT LEGS	QTY EACH PER LEG
#	DESCRIPTION	QTY		PART #
1	LEG; HYDRAULIC, LONG, 30" STROKE (LEFT)	1	-	27637-LL
2	LEG; HYDRAULIC, SHORT, 20" STROKE (LEFT)	-	1	27637
3	COVER; LONG LEG, LEFT SIDE	1	-	25068-1 ▲
4	COVER; SHORT LEG, LEFT SIDE	-	1	25069-1 ▲
5	SPACER; COVER, MOUNTING, HYD. LEGS	3	3	25070
6	VALVE BLOCK; P.O. CHECK CARTRIDGE	1	1	22765-LF
7	HOSE ASS'Y; LEG RETURN, LONG LEG	1	-	25061
8	HOSE ASS'Y; LEG RETURN, SHORT LEG	-	1	27672
9	HOSE ASS'Y; LEG UP & DOWN, LONG LEG	2	-	25152
10	HOSE ASS'Y; LEG UP & DOWN, SHORT LEG	-	2	27673
11	FITTING; ELBOW, 90°, LONG, 6MJ-6MO	1	1	H6801L-0606
12	FITTING; COUPLING, STRAIGHT, 6FJX-6FJX	1	1	H6565-0606
13	FITTING; ADAPTER, STRAIGHT, 6MJ-8MP	1	1	H2404-0608
14	FITTING; ADAPTER, ELBOW, 90°, 4MJ-6MO	1	1	H6801-0406
15	FITTING; ADAPTER, T-SHAPE, 4FJX-4MJ-4MJ	1	1	H6602-040404
16	FITTING; ADAPTER, ELBOW, 90°, 4MJ-4FX	1	1	H6500-0404
17	FITTING; ADAPTER, STRAIGHT, 4MJ-6MO	1	1	H6400-0406
18	FITTING; ELBOW, 90° EXTRA LONG, 4MJ-4MO	1	1	H6801LL-0404
19	FLAT WASHER; 5/16", STAINLESS	3	3	FWSH-031S
20	LOCK NUT; 5/16-18, NYLON INSERT, STAINLESS	3	3	LNUT-031NS
21	HEX HEAD CAP SCREW; 5/8-11 X 1 1/2", GR. 8	4	4	HHCS06311150-8
22	LOCK NUT; 5/8-11, NYLON INSERT, GR.8, ZINC	4	4	LNUT-06311-8

REFERENCE PAGE 24



VENCO VENTURO INDUSTRIES LLC
CINCINNATI, OHIO

PARTS BREAKDOWN

27634 & 27789 HYD. LEGS

DATE
07-25-17A

SUPERSEDES
02-23-17

PAGE
23

28220

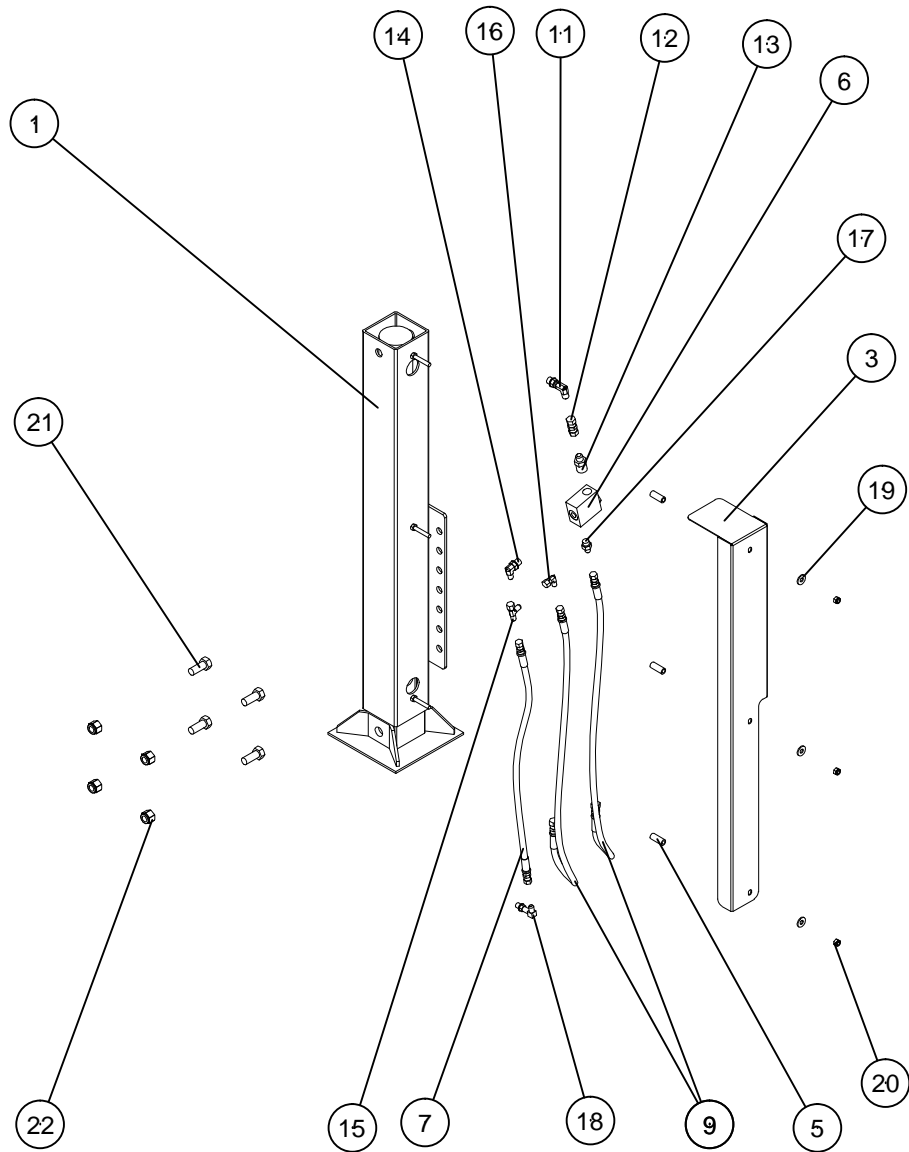

REFERENCE PAGE 23

LONG LEG

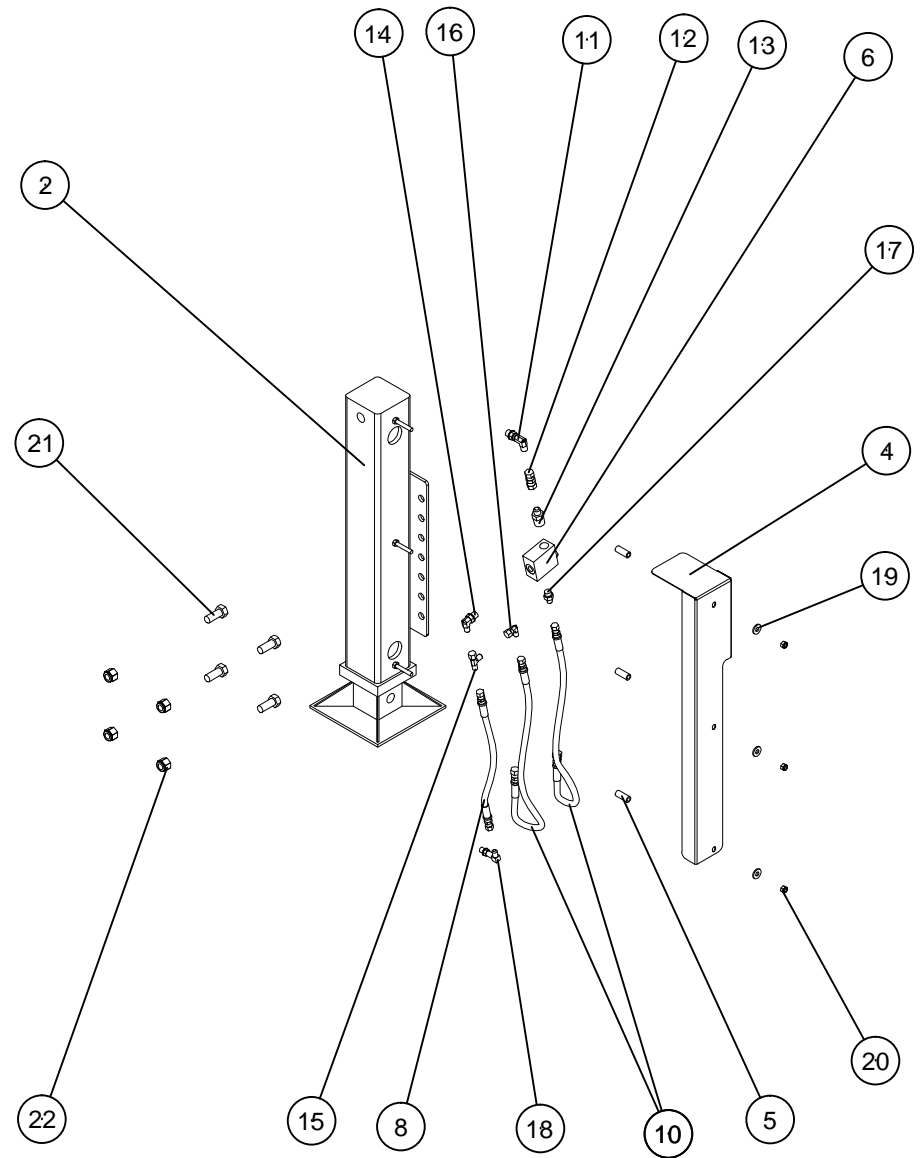

SHORT LEG



VENCO VENTURO INDUSTRIES LLC
CINCINNATI, OHIO

PARTS BREAKDOWN, HYDRAULIC LEGS

27634 & 27789 OUTRIGGERS

DATE
02-23-17

SUPERSEDES
-

PAGE

24

28221

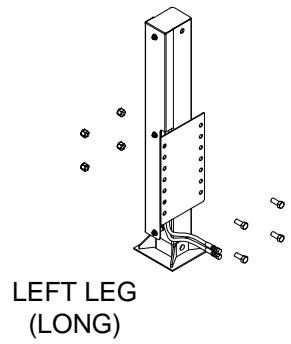

LEFT LEG
(LONG)

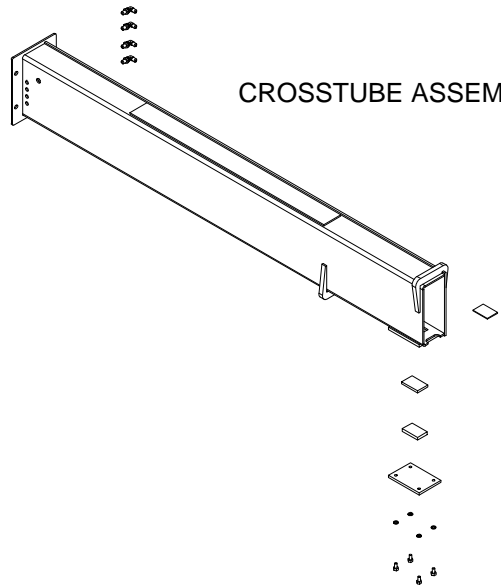

CROSSTUBE ASSEMBLY

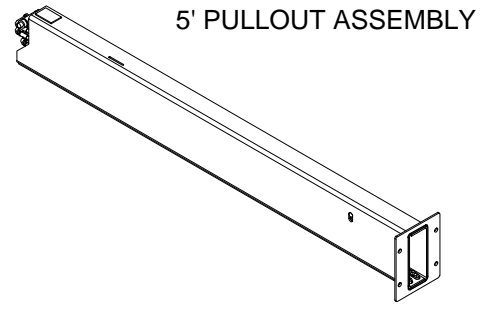

5' PULLOUT ASSEMBLY

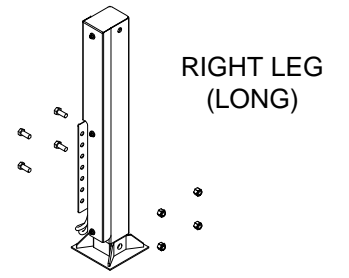

RIGHT LEG
(LONG)



VENCO VENTURO INDUSTRIES LLC
CINCINNATI, OHIO

PARTS BREAKDOWN, SECTIONS

27695 OUTRIGGER

DATE
02-23-17

SUPERSEDES
-

PAGE

31

28228

PARTS BREAKDOWN, CROSSTUBE ASSEMBLY, 27695 OUTRIGGERS

27695 OUTRIGGERS CROSSTUBE ASSEMBLY			
#	DESCRIPTION	QTY	PART #
1	CROSSTUBE; 0' X 5', SINGLE TUBE	1	27693
2	BEARING PAD; 3 1/8" X 3 1/2" X 3/8", UHMW	1	27718
3	BEARING SPACER; 3 1/8" X 2" X 1/2", A36 HRS	1	27719
4	PLATE; BEARING RETAINER, 27000 SERIES O.R.'S	1	27643
5	SHIM; VERTICAL GAP, 10 GA, 27000 SERIES O.R.'S	0-1	27631J
6	SHIM; VERTICAL GAP, 14 GA, 27000 SERIES O.R.'S	0-1	27631K
7	FITTING; BULKHEAD, ELBOW, 90°, 6MJ-6MJ	4	H2701LN-0606
8	HEX HEAD CAP SCREW; 3/8-16 X 3/4", GR. 5, ZINC	4	!HHCS03816075-5
9	LOCK WASHER; 3/8", GR. 5, ZINC	4	!LWSH-038

REFERENCE PAGE 33



VENCO VENTURO INDUSTRIES LLC
CINCINNATI, OHIO

PARTS BREAKDOWN

DATE
02-23-17

PAGE
32

CROSSTUBE ASSEMBLY

SUPERSEDES
-

28229

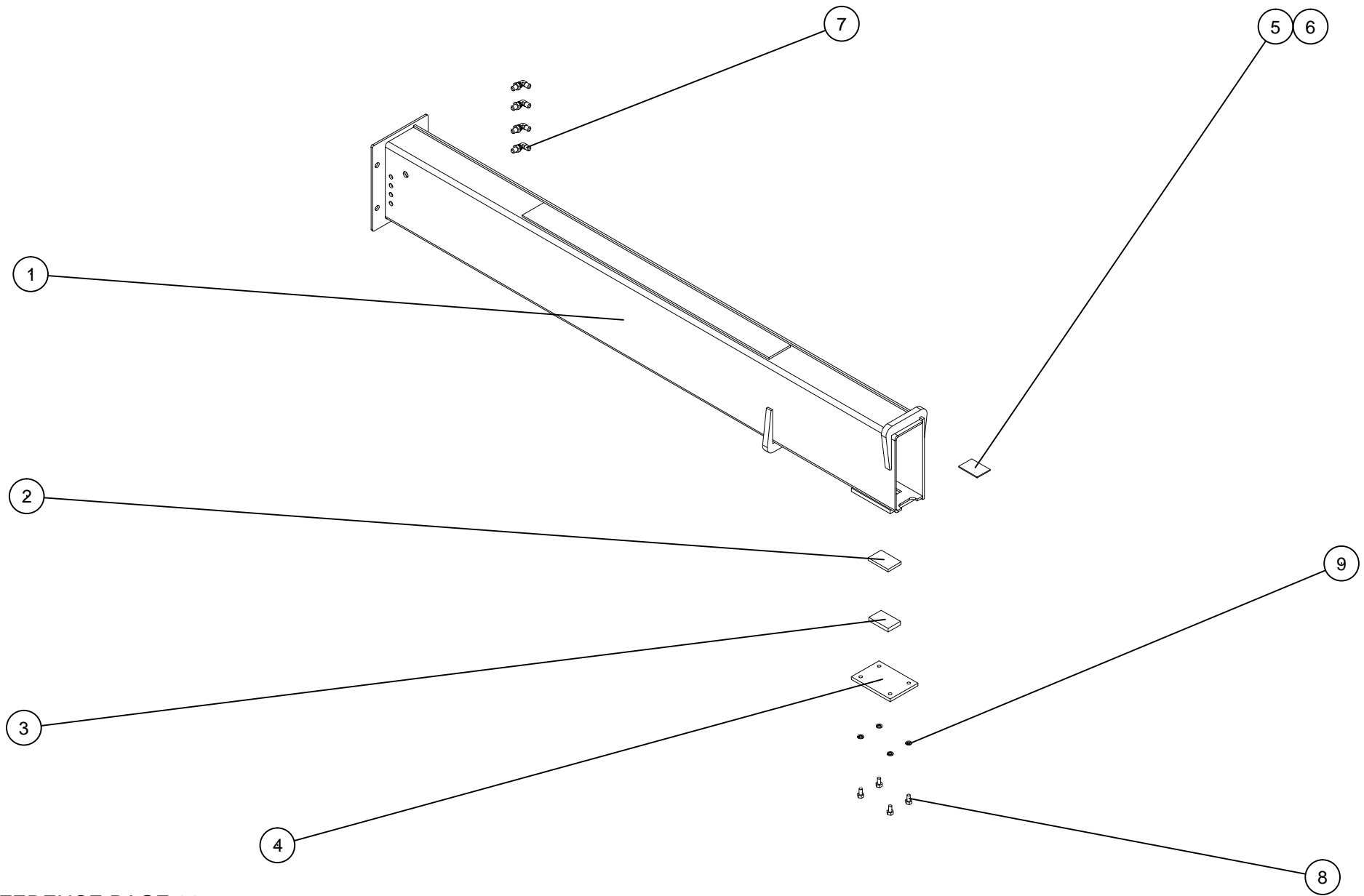

REFERENCE PAGE 32



VENCO VENTURO INDUSTRIES LLC
CINCINNATI, OHIO

PARTS BREAKDOWN, CROSSTUBE ASSEMBLY

27695 OUTRIGGER

DATE
02-23-17

SUPERSEDES
-

PAGE

33

28230

PARTS BREAKDOWN, 5' PULLOUT ASSEMBLY, 27695 OUTRIGGER

27695 OUTRIGGER 5' PULLOUT ASSEMBLY			
ITEM	DESCRIPTION	QTY	PART #
1	PULLOUT TUBE; 5' EXT., 27000 SERIES O/R	1	27694
2	EXTENSION CYLINDER; 60" STROKE, 2" BORE	1	27692
3	BEARING PAD; 3 1/8" x 3 1/2" x 3/8", UHMW	1	27718
4	SHAFT; INBOARD, EXT. CYL., CROSSTUBE	1	27638
5	SHAFT; OUTBOARD, EXT. CYL., PULLOUT	1	27639
6	SET COLLAR; 3/4" ID, 1 1/4" OD	4	'00210
7	BUSHING; 14GA, 3/4" ID, 1 1/4" OD, ZINC	2	12534-14
8	BUSHING; 10GA, 3/4" ID, 1 1/4" OD, ZINC	4	12534-1
9	CLAMP SUPPORT; HOSE CLAMP, CYL. MOUNT	1	27689
10	HOSE CLAMP; ADJUSTABLE, GROMMET	2	27700
▲ 11	HOSE ASS'Y; CROSSOVER, LEG UP/DOWN	2	27715
12	HOSE ASS'Y; RETRACTION, CYLINDER	1	27714
13	HOSE ASS'Y; EXTENSION, CYLINDER	1	27713
14	FITTING; ADAPTER, ELBOW, 90°, 6MJ-6MO	2	H6801L-0606
15	FITTING; BULKHEAD, ELBOW, 90°, 6MJ-6MJ	2	H2701LN-0606

REFERENCE PAGE 35



VENCO VENTURO INDUSTRIES LLC
CINCINNATI, OHIO

TITLE

PARTS BREAKDOWN LIST

5' PULLOUT ASSEMBLY

DATE

08-13-18A

SUPERSEDES

02-23-17

PAGE

34

28231

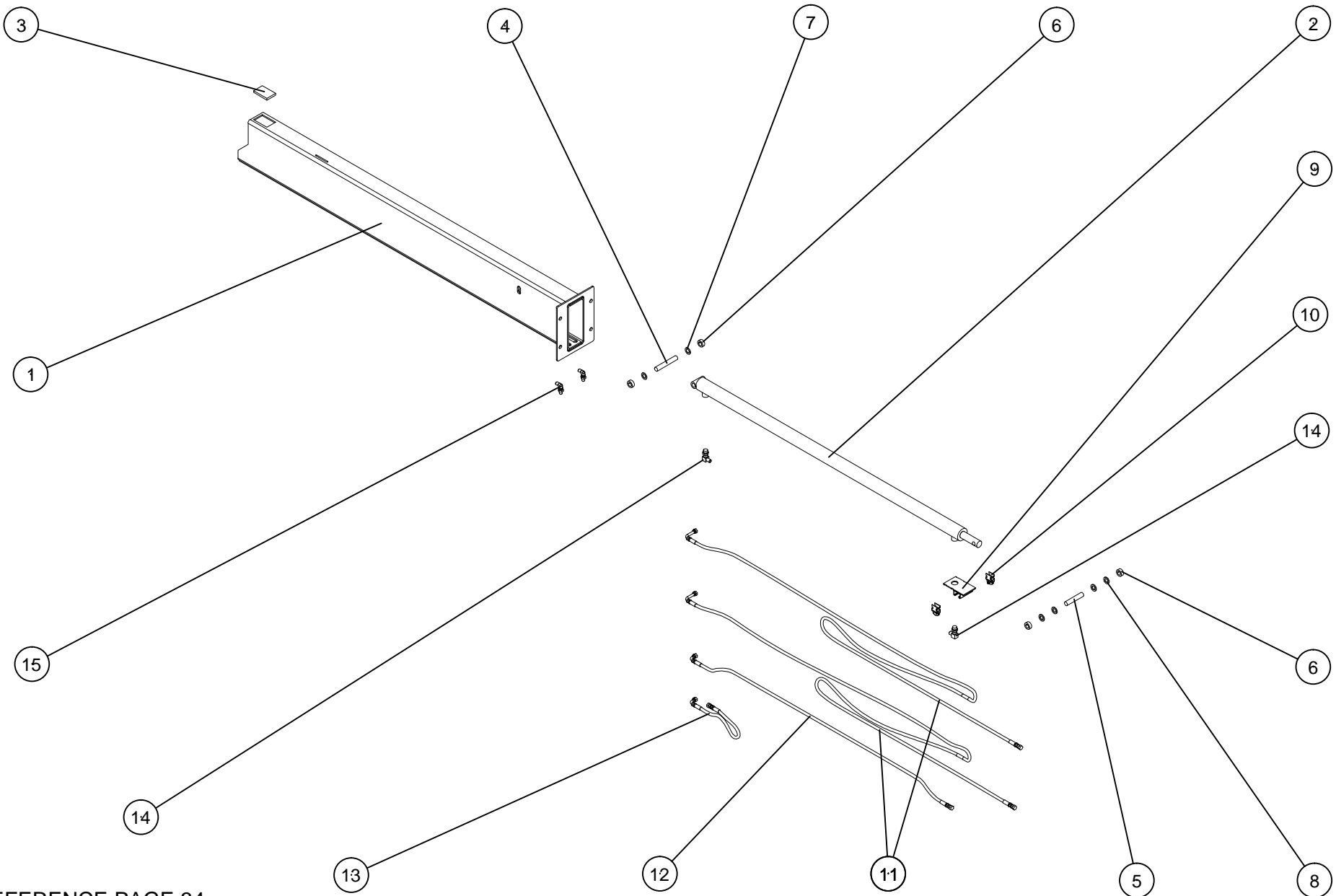

REFERENCE PAGE 34



VENCO VENTURO INDUSTRIES LLC
CINCINNATI, OHIO

PARTS BREAKDOWN, 5' PULLOUT ASSEMBLY

27695 OUTRIGGER

DATE
02-23-17

SUPERSEDES
-

PAGE

35

28232

PARTS BREAKDOWN, LONG LEGS ASSEMBLY, 27695 OUTRIGGER

27695 OUTRIGGER LONG LEGS ASSEMBLY		RIGHT LEG	LEFT LEG	QTY EACH PER LEG
#	DESCRIPTION	QTY		PART #
1	LEG; HYDRAULIC, LONG, 30" STROKE, RIGHT	1	-	25055-1
2	LEG; HYDRAULIC, LONG, 30" STROKE, LEFT	-	1	25055-2
3	COVER; LONG LEG, LEFT SIDE	-	1	25068-1
4	COVER; LONG LEG, RIGHT SIDE	1	-	25068-2
5	SPACER; COVER, MOUNTING, HYD. LEGS	3	3	25070
6	VALVE BLOCK; P.O. CHECK CARTRIDGE	1	1	22765-LF
7	HOSE ASS'Y; LEG RETURN, LONG LEG	1	1	25061
8	HOSE ASS'Y; LEG UP & DOWN, LONG LEG	2	2	25152
9	FITTING; ELBOW, 90°, LONG, 6MJ-6MO	1	1	H6801L-0606
10	FITTING; COUPLING, STRAIGHT, 6FJX-6FJX	1	1	H6565-0606
11	FITTING; ADAPTER, STRAIGHT, 6MJ-8MP	1	1	H2404-0608
12	FITTING; ADAPTER, ELBOW, 90°, 4MJ-6MO	1	1	H6801-0406
13	FITTING; ADAPTER, T-SHAPE, 4FJX-4MJ-4MJ	1	1	H6602-040404
14	FITTING; ADAPTER, ELBOW, 90°, 4MJ-4FX	1	1	H6500-0404
15	FITTING; ADAPTER, STRAIGHT, 4MJ-6MO	1	1	H6400-0406
16	FITTING; ELBOW, 90° EXTRA LONG, 4MJ-4MO	1	1	H6801LL-0404
17	FLAT WASHER; 5/16", STAINLESS	3	3	FWSH-031S
18	LOCK NUT; 5/16-18, NYLON INSERT, STAINLESS	3	3	LNUT-031NS
19	HEX HEAD CAP SCREW; 5/8-11 X 1 1/2", GR. 8	4	4	HHCS06311150-8
20	LOCK NUT; 5/8-11, NYLON INSERT, GR.8, ZINC	4	4	LNUT-06311-8

REFERENCE PAGE 37



VENCO VENTURO INDUSTRIES LLC
CINCINNATI, OHIO

PARTS BREAKDOWN

LONG LEGS ASSEMBLY

DATE
02-23-17

SUPERSEDES
-

PAGE
36

28233

PARTS BREAKDOWN, LONG LEGS ASSEMBLY, 27695 OUTRIGGER

RIGHT LEG

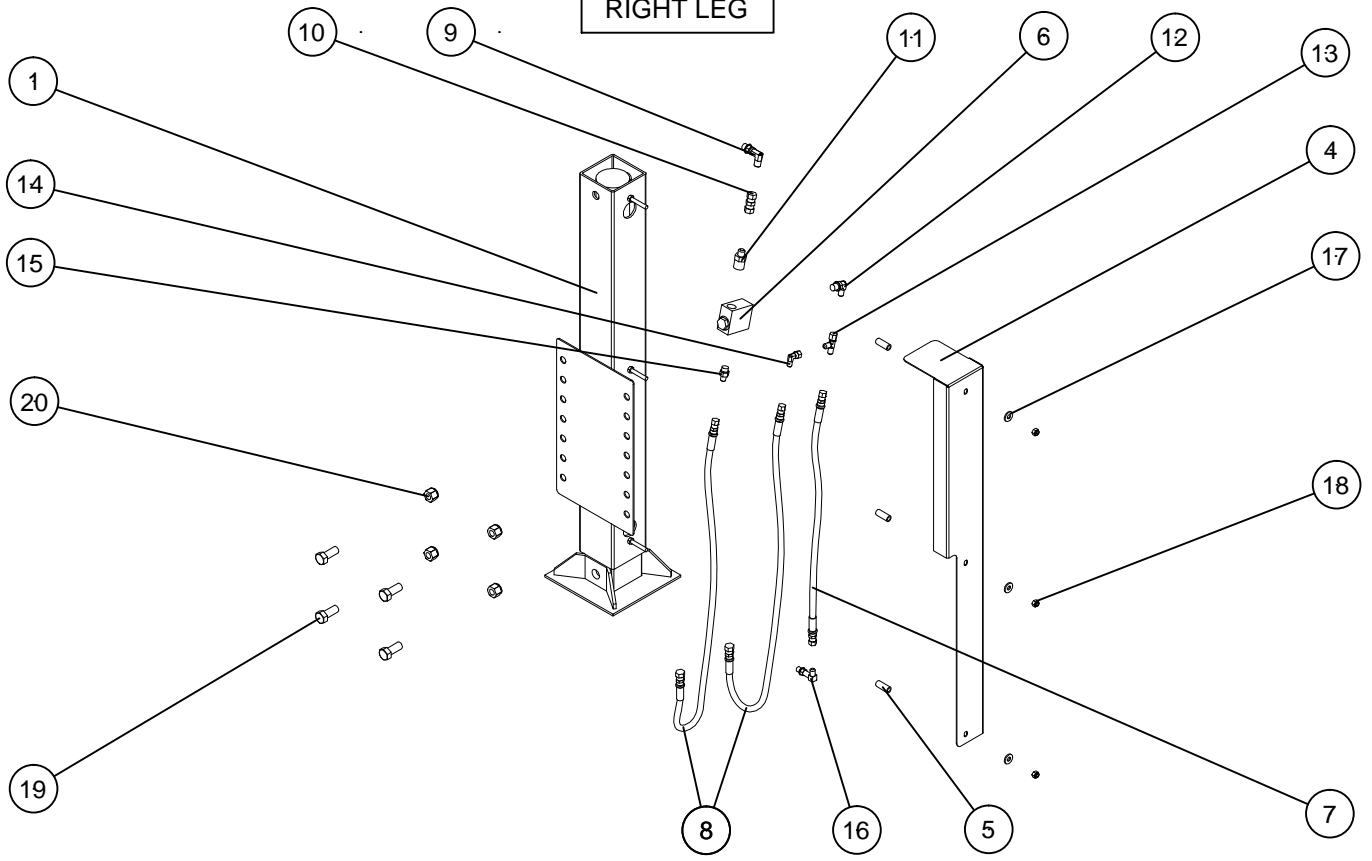

LEFT LEG

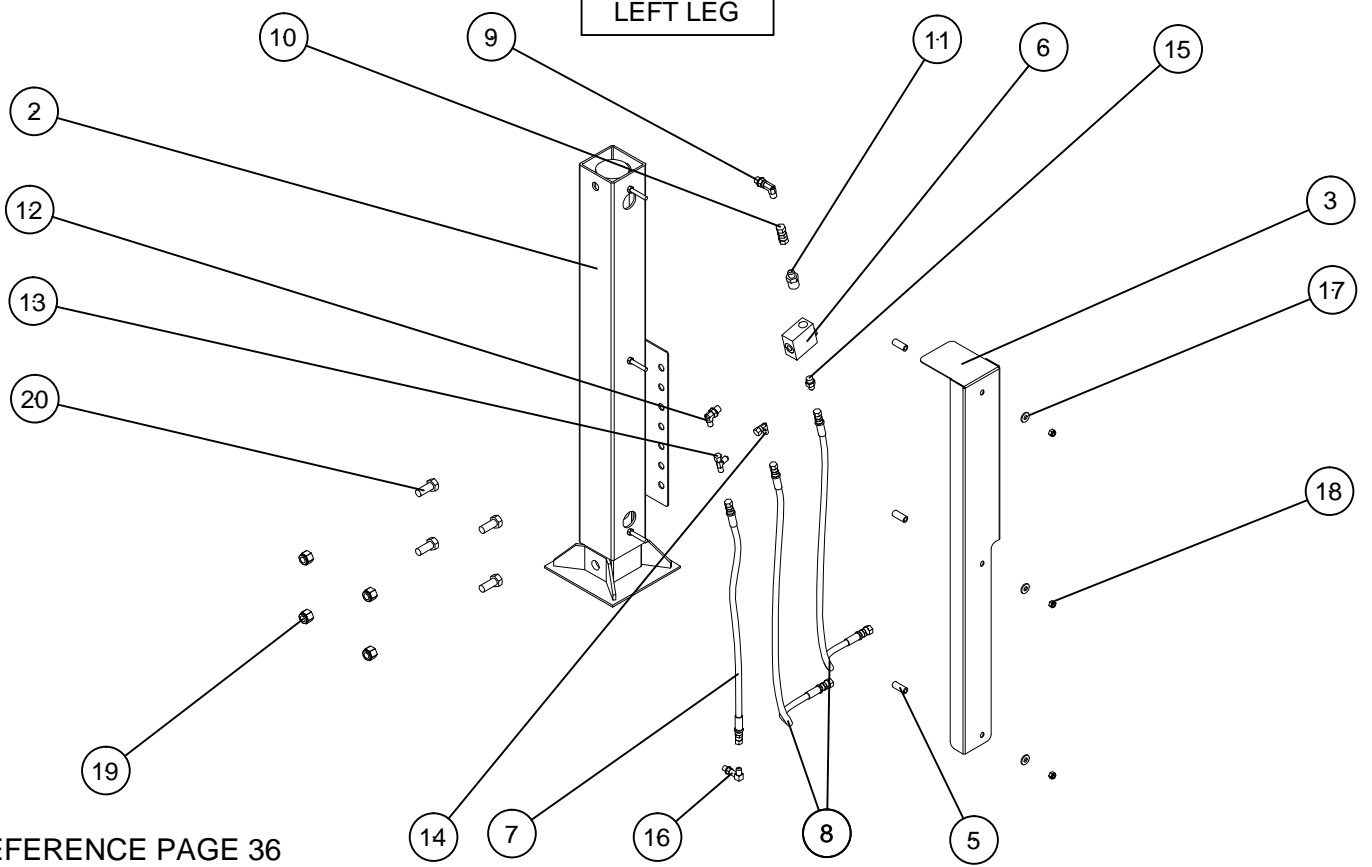

REFERENCE PAGE 36



VENCO VENTURO INDUSTRIES LLC
CINCINNATI, OHIO

PARTS BREAKDOWN

LONG LEGS ASSEMBLY

DATE
02-23-17

SUPERSEDES
-

PAGE
37

28234

PARTS BREAKDOWN, SHORT LEGS ASSEMBLY, 27695 OUTRIGGER

27695 OUTRIGGER SHORT LEGS ASSEMBLY		RIGHT LEG	LEFT LEG	QTY EACH PER LEG
#	DESCRIPTION	QTY		PART #
1	LEG; HYDRAULIC, SHORT, 20" STROKE, RIGHT	1	-	25083-2
2	LEG; HYDRAULIC, SHORT, 20" STROKE, LEFT	-	1	25083-1
3	COVER; SHORT LEG, LEFT SIDE	-	1	25064-1
4	COVER; SHORT LEG, RIGHT SIDE	1	-	25064-2
5	SPACER; COVER, MOUNTING, HYD. LEGS	3	3	25070
6	VALVE BLOCK; P.O. CHECK CARTRIDGE	1	1	22765-LF
7	HOSE ASS'Y; LEG RETURN, SHORT LEG	1	1	27672
8	HOSE ASS'Y; LEG UP & DOWN, SHORT LEG	2	2	27673
9	FITTING; ELBOW, 90°, LONG, 6MJ-6MO	1	1	H6801L-0606
10	FITTING; COUPLING, STRAIGHT, 6FJX-6FJX	1	1	H6565-0606
11	FITTING; ADAPTER, STRAIGHT, 6MJ-8MP	1	1	H2404-0608
12	FITTING; ADAPTER, ELBOW, 90°, 4MJ-6MO	1	1	H6801-0406
13	FITTING; ADAPTER, T-SHAPE, 4FJX-4MJ-4MJ	1	1	H6602-040404
14	FITTING; ADAPTER, ELBOW, 90°, 4MJ-4FX	1	1	H6500-0404
15	FITTING; ADAPTER, STRAIGHT, 4MJ-6MO	1	1	H6400-0406
16	FITTING; ELBOW, 90° EXTRA LONG, 4MJ-4MO	1	1	H6801LL-0404
17	FLAT WASHER; 5/16", STAINLESS	3	3	!FWSH-031S
18	LOCK NUT; 5/16-18, NYLON INSERT, STAINLESS	3	3	!LNUT-031NS
19	HEX HEAD CAP SCREW; 5/8-11 X 1 1/2", GR. 8	4	4	!HHCS06311150-8
20	LOCK NUT; 5/8-11, NYLON INSERT, GR.8, ZINC	4	4	!LNUT-06311-8

REFERENCE PAGE 39



VENCO VENTURO INDUSTRIES LLC
CINCINNATI, OHIO

PARTS BREAKDOWN

DATE
07-12-19A

PAGE
38

SHORT LEGS ASSEMBLY

SUPERSEDES
02-23-17

28235

PARTS BREAKDOWN, SHORT LEGS ASSEMBLY, 27695 OUTRIGGER

RIGHT LEG

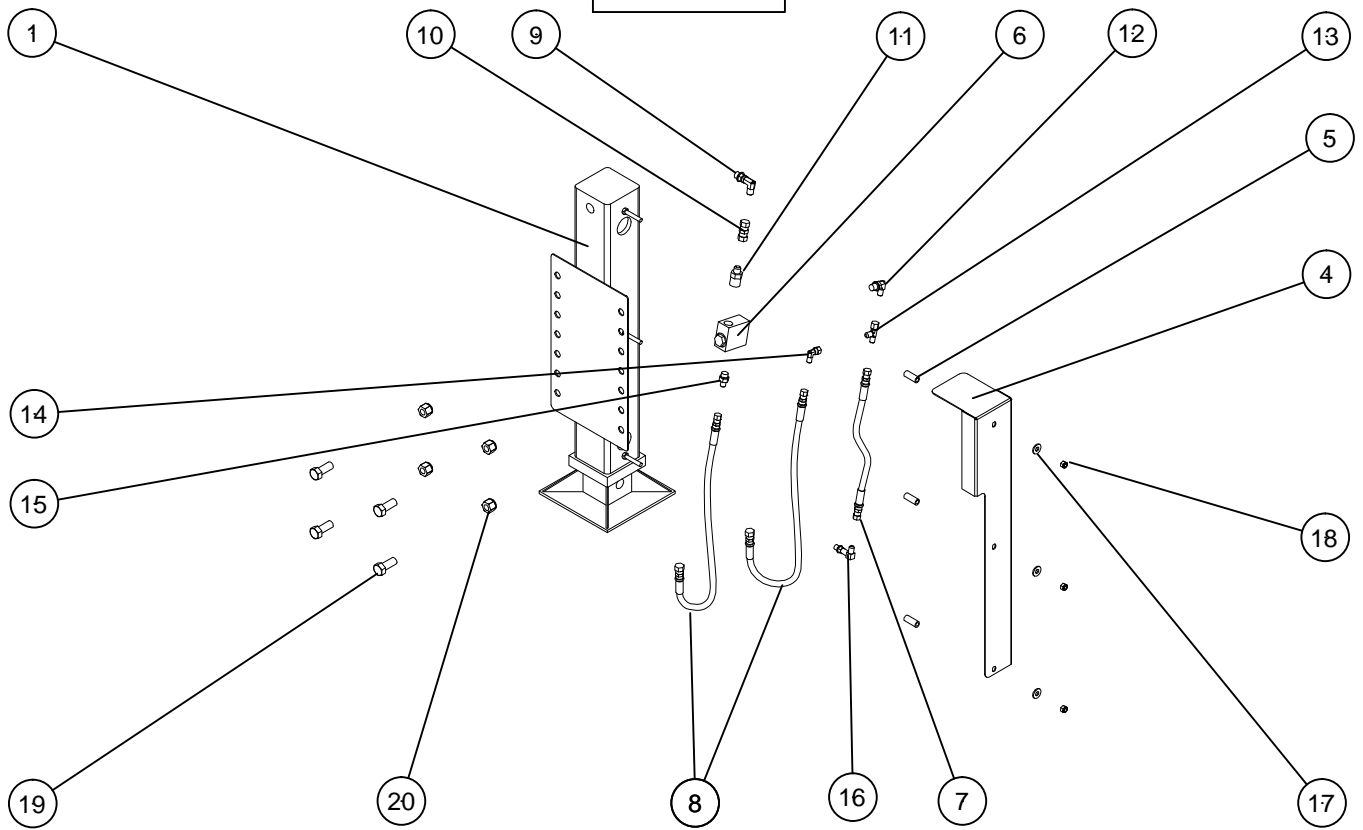

LEFT LEG

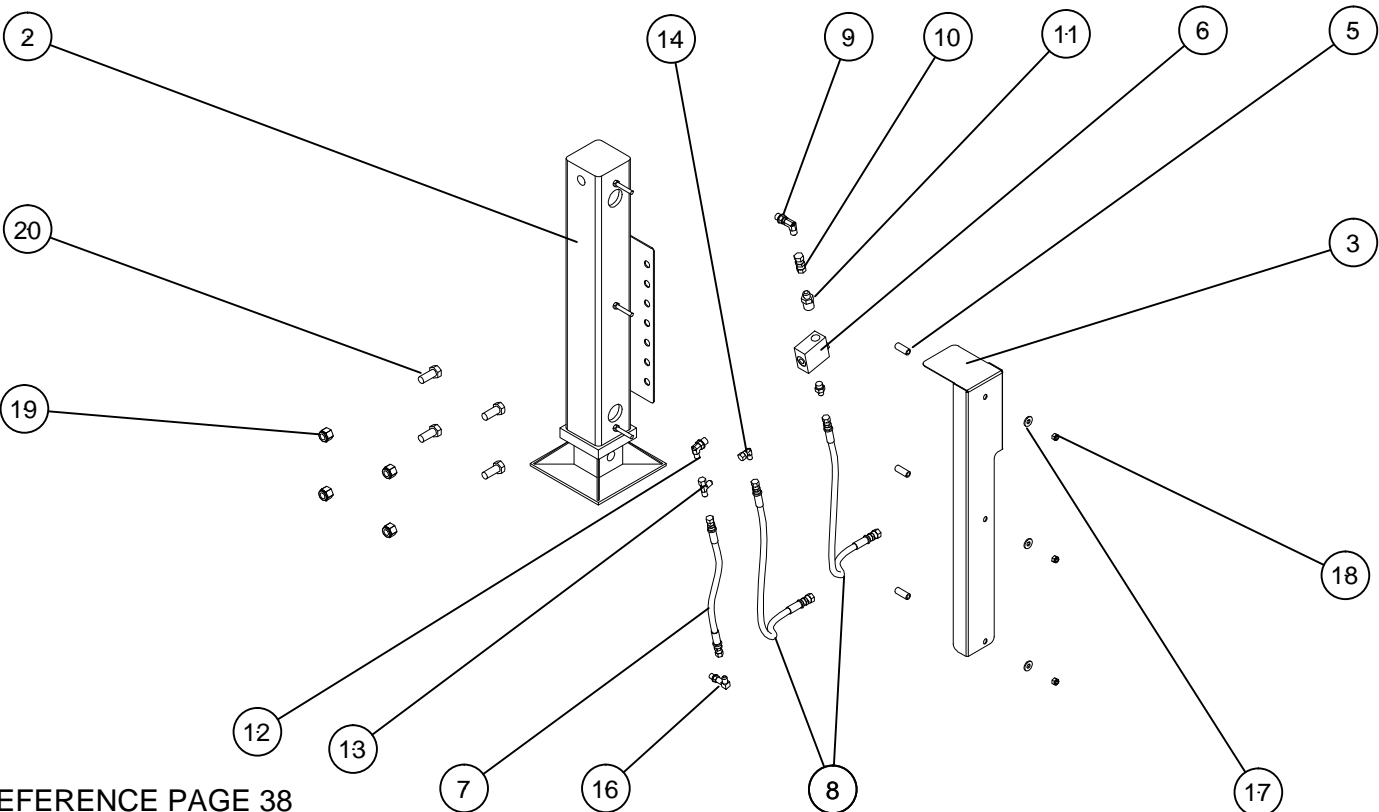

REFERENCE PAGE 38



VENCO VENTURO INDUSTRIES LLC
CINCINNATI, OHIO

PARTS BREAKDOWN

SHORT LEGS ASSEMBLY

DATE
02-23-17

SUPERSEDES
-

PAGE
39

28236



VENTURO CRANES LIMITED WARRANTY POLICY

Venturo products are built to last...we guarantee them.

As a purchaser of any new Venturo product covered by warranty, you will receive 1 year of the most complete coverage available...and, at no added cost to you.

1-Year Limited Warranty Policy

This limited policy warrants new products of Venturo to be free from defects in material and workmanship for a period of one (1) year from date of original installation. OEM products or accessories purchased by Venturo as part of or offered with our product will carry the OEM manufacturer's respective warranty. Our warranty covers:

- ***Repair or replacement of product***
- ***Labor to repair or replace product***
- ***Freight to return and/or replace product***

We shall not be liable for any contingent liabilities arising out of the improper function of any products. Warranty shall become void if the product is improperly installed, modified, damaged, abused or used for application other than intended use. There is no warranty of merchantability, fitness for a particular purpose, warranty arising from course of dealing or usage of trade, or any other implied or expressed warranty, except as made specifically herein. This warranty supersedes all previous warranties, written or implied.

Warranty Claims

Venco Venturo Industries LLC will make a good faith effort for prompt correction or other adjustment with respect to any product, which proves to be defective after our inspection and within the warranty period. Before any repairs are attempted or before returning any product, your Venturo Distributor is required to obtain a warranty claim number. This number is necessary for any claim to be considered. To obtain a warranty claim number, Venturo requires the model and serial number. Only authorized Venturo Distributors can perform warranty. For the name and address of your local Venturo Distributor call the **Warranty Claim Department - 513-772-8448**.

WARNING - It is the responsibility of the installer to ensure the installation is completed according to the manufacturer's recommendations, ensure the ultimate user understands how to operate product in a safe manner, and understands the need for regular service and maintenance by an authorized Venturo Distributor. No modifications or alterations may be made to any Venturo product without the expressed written consent of Venco Venturo Industries LLC. Installation of any Venturo product must be done by an authorized Venturo Distributor, to the standards of the industry; including maintenance, service and affixing of all instruction, safety and warning decals. Users should be instructed as to the safe operation at time of delivery. Maintenance, service, operation and safety warning decals are available on request from Venco Venturo Industries LLC.

VENCO VENTURO INDUSTRIES LLC
12110 BEST PLACE | CINCINNATI, OHIO 45241
P: 800-226-2238 | F: 513-326-5427
www.venturo.com