

# **PARTS & INSTALLATION MANUAL**

---

## **ET12K(X)(P)-15'**

---

Included in this manual:

### **ET12K**

- 3,500 lbs Electric Telescopic Service Crane
- 7 – 11 – 15 ft Manual, Pullout, Boom Extensions

### **ET12KX**

- 3,500 lbs Electric Telescopic Service Crane
- 7 – 11 ft Powered, Single-Stage, Boom Extension
- 11 – 15 ft Manual, Pullout, Boom Extension

### **ET12KXP-15'**

- 3,500 lbs Electric Telescopic Service Crane
- 7 – 11 ft Powered, Single-Stage, Boom Extension
- 11 – 15 ft Manual, Pullout, Boom Extension
- Proportional Controls

VENCO VENTURO INDUSTRIES LLC  
12110 BEST PLACE | CINCINNATI, OHIO 45241  
800-226-2238



# ET12KX-15'

INST-28070 - 3/29/2024 (Rev: E0)

<b>7607100A</b>	<b>DESCRIPTION &amp; SPECIFICATIONS</b>
28071	INSTALLATION DIMENSIONS
21592	BASE MOUNTING DIMENSIONS
21575	CAPACITY CHART
16941	TYPICAL REINFORCEMENT FOR MOUNTING CRANE ON TOP OF SERVICE BODY
21594	21571 MOUNTING PEDESTAL
<b>7607150A</b>	<b>SAFETY</b>
850711	SAFETY & HAZARDS - GENERAL, 1/2
850712	SAFETY & HAZARDS - GENERAL, 2/2
15394	VEHICLE & CRANE ELECTRIC HAZARD INFORMATION
21353	SAFETY DECALS
21354	DECALS FOR ET CRANES
28545	ADDITIONAL DECALS
28551	MODEL & CAPACITY DECALS
<b>7607200A</b>	<b>INSTALLATION</b>
711105	CABLE & BATTERY REQUIREMENTS - ET & HT CRANES
15660	CABLE & BATTERY INSTALLATION DRAWING
20906-12	STABILITY TESTING
20907	STABILITY CHART
22245	WIRE ROPE INSTALLATION
20872	ADJUSTABLE BOOM REST
<b>7607300A</b>	<b>MAINTENANCE &amp; SERVICE</b>
900530a	OPERATION & MAINTENANCE INSTRUCTIONS
900530b	OPERATION & MAINTENANCE INSTRUCTIONS
900530c	OPERATION & MAINTENANCE INSTRUCTIONS
21306	LUBRICATION & MAINTENANCE CHART
19963	MINIMUM VOLTAGE TEST
23225	WIRE ROPE & HOOK SPECIFICATIONS
23084	MANUAL OVERRIDE INSTRUCTIONS, NON-PROPORTIONAL
23775	MANUAL OVERRIDE INSTRUCTIONS, PROPORTIONAL
<b>7607400A</b>	<b>REPLACEMENT PARTS</b>
28063	REPLACEMENT PARTS DRAWING; MECHANISM
28064	REPLACEMENT PARTS LIST; MECHANISM
28066	REPLACEMENT FASTENERS DRAWING; MECHANISM
28067	REPLACEMENT FASTENERS LIST; MECHANISM
28123	REPLACEMENT PARTS DRAWING; BOOM ASSEMBLIES
28124	REPLACEMENT PARTS LIST; BOOM ASSEMBLIES
28125	REPLACEMENT FASTENERS DRAWING; BOOM ASSEMBLIES
28126	REPLACEMENT FASTENERS LIST; BOOM ASSEMBLIES
24102	BOOM ROUND CORD REEL 28190-2
21600	21515 ELECTRICAL COMPONENT ASSY
26521	WIRING DIAGRAM, ET8/12K SERIES CRANES
26536	WIRING DIAGRAM, ET8/12K SERIES CRANES W/ WINCH CONTACTOR
26522	WIRING DIAGRAM, ET8/12KX SERIES CRANES
26537	WIRING DIAGRAM, ET8/12KX SERIES CRANES W/ WINCH CONTACTOR
26523	WIRING DIAGRAM, ET8/12KXP SERIES CRANES
26538	WIRING DIAGRAM, ET8/12KXP SERIES CRANES W/ WINCH CONTACTOR
28037	HYDRAULIC SYSTEM COMPONENTS REPLACEMENT PARTS DRAWING
21602	HYDRAULIC SYSTEM SCHEMATIC, NON-PROPORTIONAL
28077	HYDRAULIC SYSTEM SCHEMATIC, PROPORTIONAL
21292	REPLACEMENT PARTS LIST; SINGLE / 2-POLE SLIP-RING
21293	REPLACEMENT PARTS DRAWING; SINGLE / 2-POLE SLIP-RING
23076	21991 PENDANT; REPLACEMENT PARTS DRAWING / LIST (3 FUNCTION)
23075	21990 PENDANT; REPLACEMENT PARTS DRAWING / LIST (4 FUNCTION)
23786	22158 RADIO; REPLACEMENT PARTS DRAWING/LIST
21741	21556 WINCH REPLACEMENT PARTS DRAWING / LIST
16942	20873 HYDRAULIC POWER UNIT REPLACEMENT PARTS DRAWING / LIST
21973	21735 SLEWING REPLACEMENT PARTS DRAWING
28543	DECAL PLACEMENT
28552	FIELD SERVICE LABEL KITS; ET12 SERIES (7-11-15)
12-00073_VNT1	WARRANTY PAGE

**SECTION 100**

**DESCRIPTION**

**&**

**SPECIFICATIONS**



VENCO VENTURO INDUSTRIES LLC  
CINCINNATI, OHIO

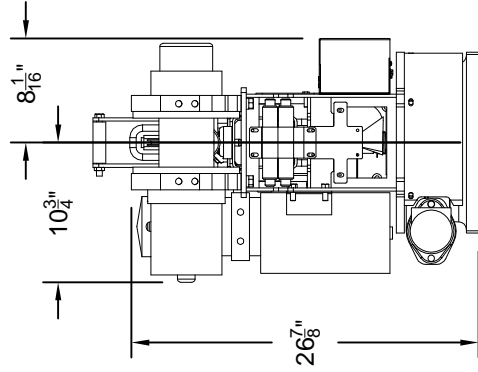
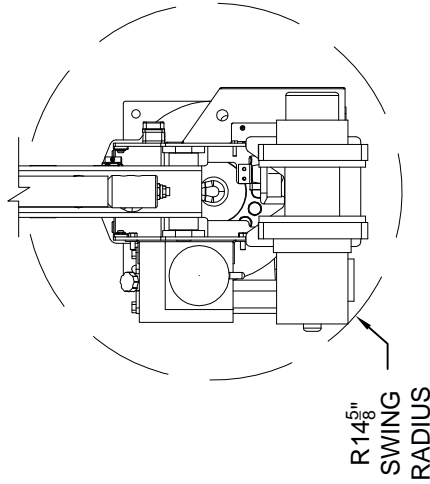
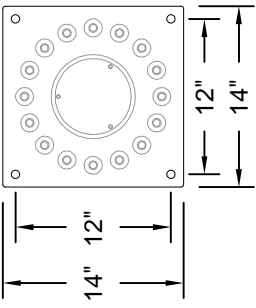

THIS SECTION SCALED 2:1 FOR CLARITY

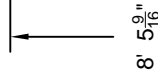

2' 1<sup>7</sup>/<sub>8</sub>" TWO-PART LINE, FROM CENTER OF ROTATION @ 75°

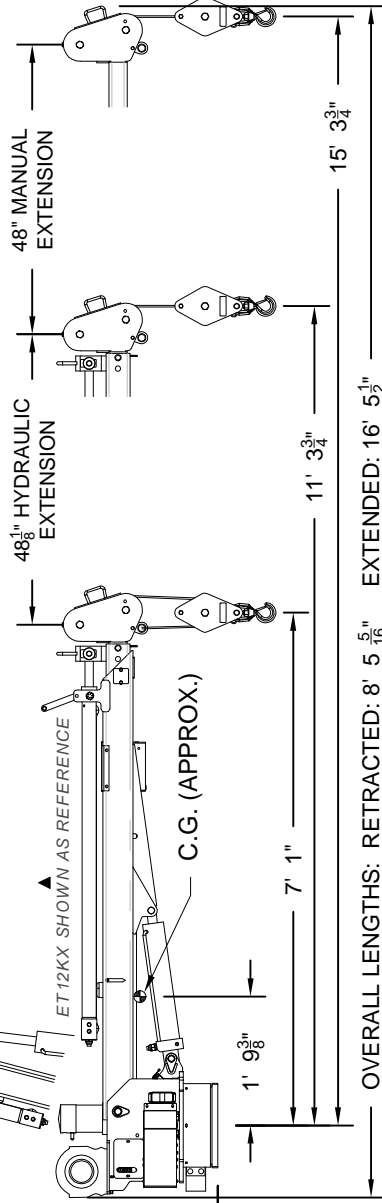

# WARNING

- These products are not passenger lifts. They are not designed or intended to be used to lift, support or otherwise transport personnel.

SERIAL NUMBER RANGES:  
ET12 SERIES: 25B000156 - CURRENT

LOAD BLOCK FOR SINGLE AND DOUBLE LINE OPERATION

## INSTALLATION DIMENSIONS

ET12 GEN.C SERIES, 7' - 11' - 15' BOOM

VENCO VENTURO INDUSTRIES LLC  
CINCINNATI, OHIO



DATE  
03-13-19A

SUPERSEDES  
03-05-19

SECTION  
C100

28071

# 21735 - SQUARE

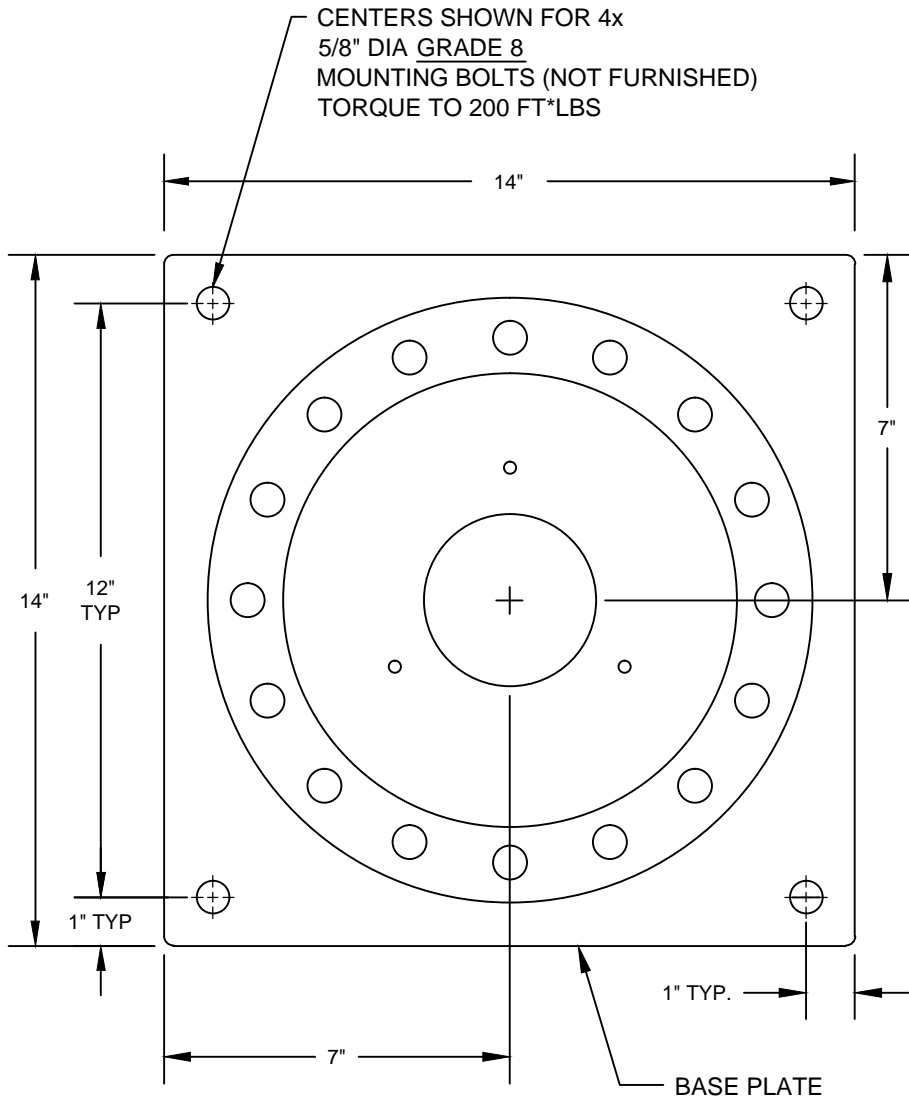

# 21735-WRB/CRB - RECTANGULAR

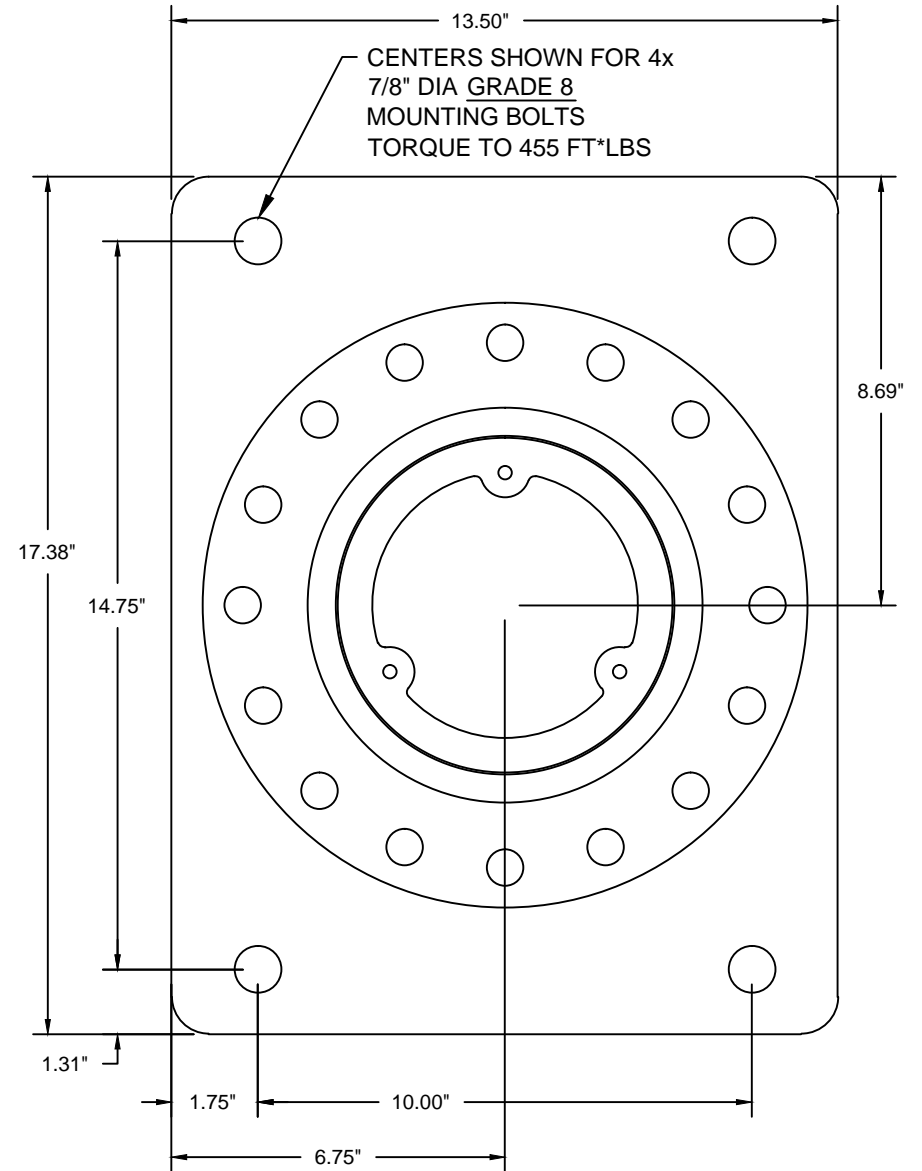

VENCO VENTURO INDUSTRIES LLC  
CINCINNATI, OHIO

TITLE  
21735 BASE MOUNTING DIMENSIONS

ET8/12/16/18 CRANES

DATE  
03-06-23G

SUPERSEDES  
10-22-14F

SECTION  
C100

21592

▲ ET12 SERIES, 7'-11'-15' BOOM

CRANE SERIAL NUMBER: \_\_\_\_\_

MAXIMUM LOAD CAPACITY CHART

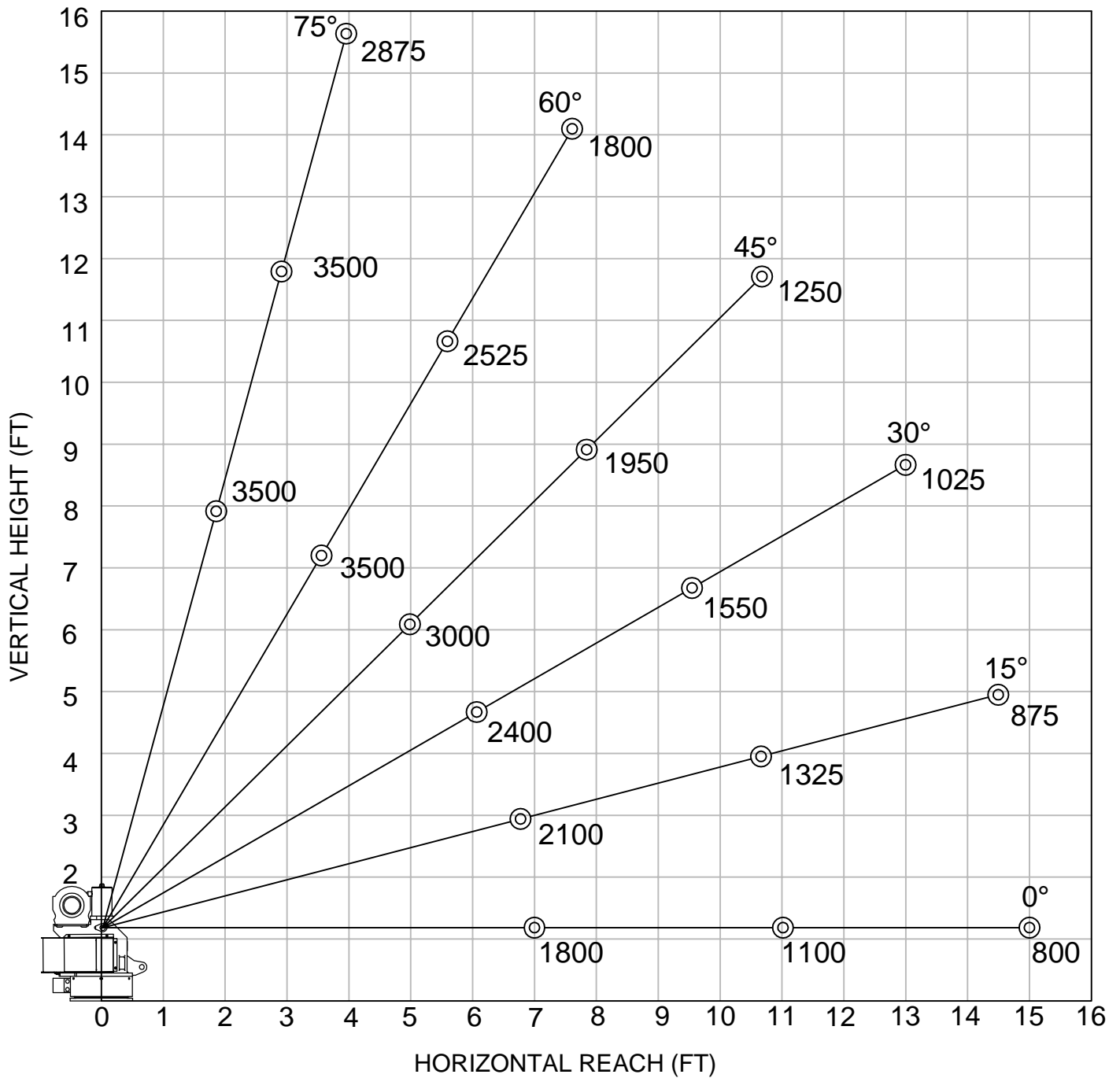

WEIGHT OF LOAD HANDLING DEVICES ARE PART OF THE LOAD AND MUST BE DEDUCTED FROM THE GROSS CAPACITY.

LOAD BLOCK USAGE

- 1 PART LINE FOR LOADS LESS THAN 1750 LBS
- 2 PART LINE FOR LOADS OF 1750 LBS AND GREATER

WEIGHT OF LOAD BLOCK = 24 LBS



VENCO VENTURO INDUSTRIES LLC  
CINCINNATI, OHIO

TITLE	DATE	SECTION
MAXIMUM LOAD CAPACITY	03-13-19D	C100
ET12 SERIES, 7'-11'-15' BOOM	SUPERSEDES	
	05-03-16C	21575

ITEM NO.	DESCRIPTION	MINIMUM RECOMMENDED MATERIAL SIZE
1	TOP PLATE	STEEL PLATE
2	CORNER POST	3" x 3" x 1/4" STEEL ANGLE
3	SHEAR WEB	12 Ga.
4	STABILIZER REINFORCEMENT PLATE	3/16" THICK STEEL PLATE
5	GUSSET	1/4" x 4" H.R. STEEL (NOT SHOWN)

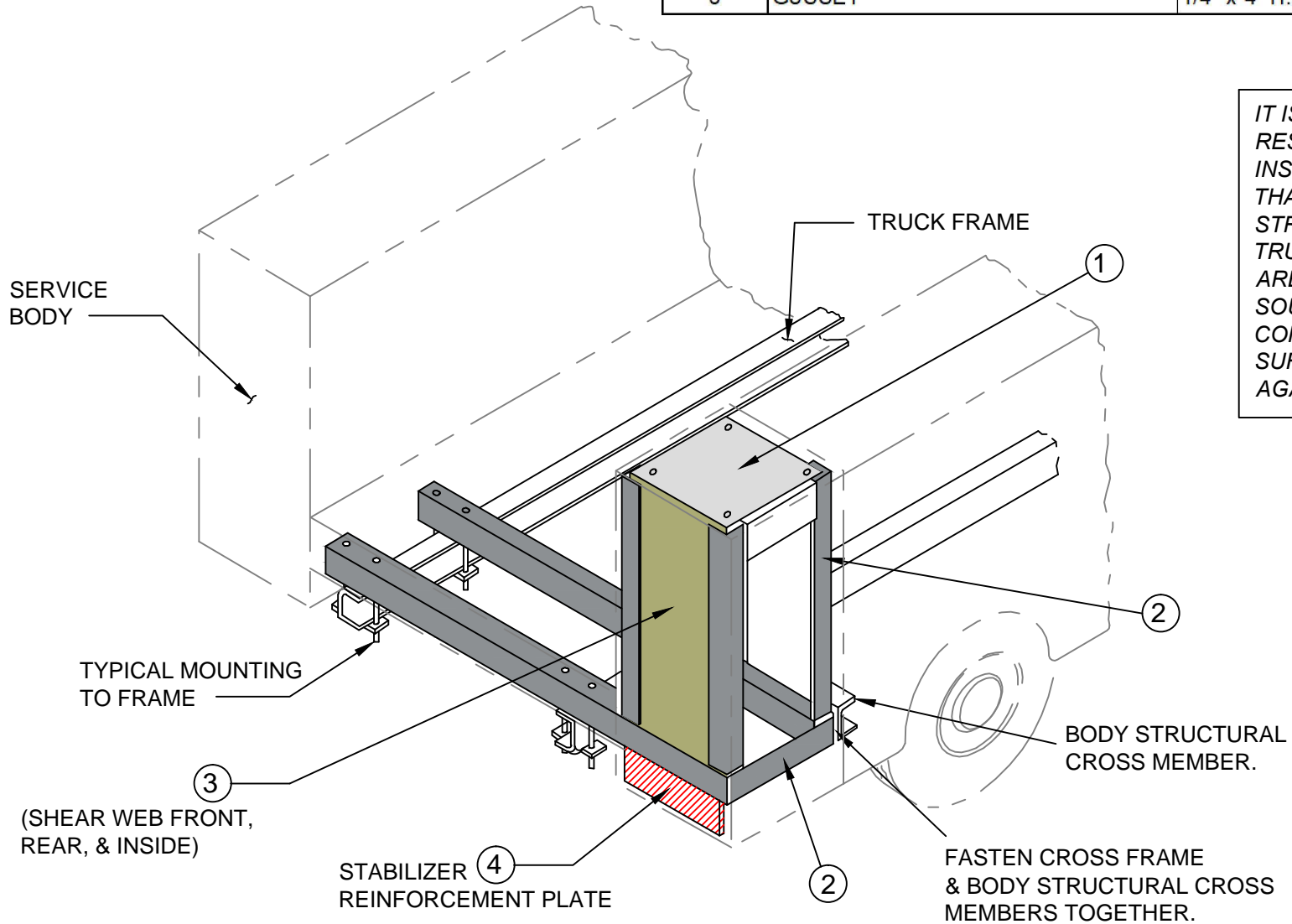

*IT IS THE SOLE RESPONSIBILITY OF THE INSTALLER TO INSURE THAT THE TOTAL STRUCTURE OF CRANE, TRUCK, AND STABILIZERS ARE STRUCTURALLY SOUND AND THAT THE COMPLETED VEHICLE HAS SUFFICIENT STABILITY AGAINST OVERTURNING.*

ILLUSTRATIONS NOT TO SCALE



VENCO VENTURO INDUSTRIES LLC  
CINCINNATI, OHIO

TITLE  
INSTALLATION DRAWING

ET6/8/12K(X)

DATE  
03-06-23D

SUPSEDES  
01-28-15C

SECTION  
C100

16941

# 21571-XX MOUNTING PEDESTAL

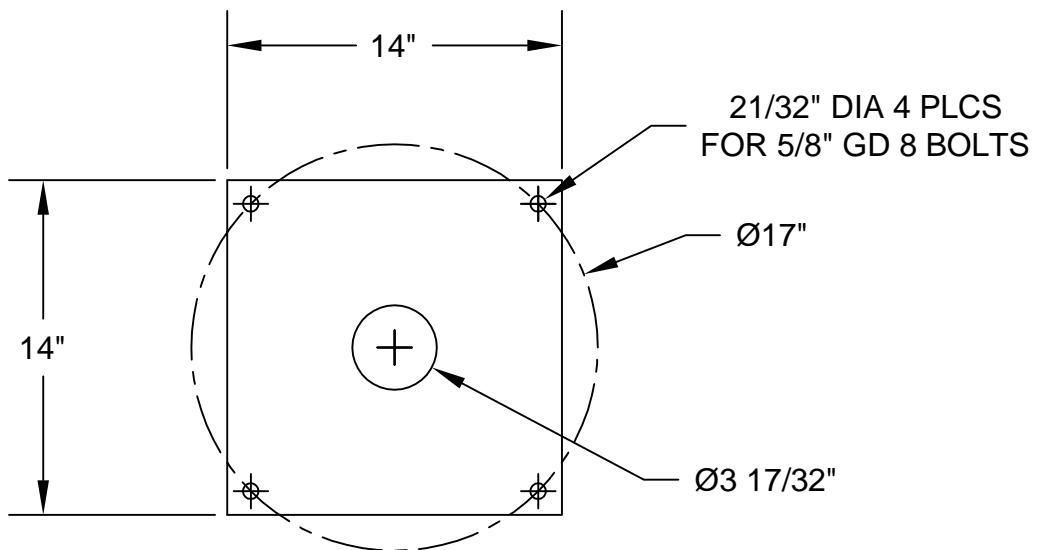
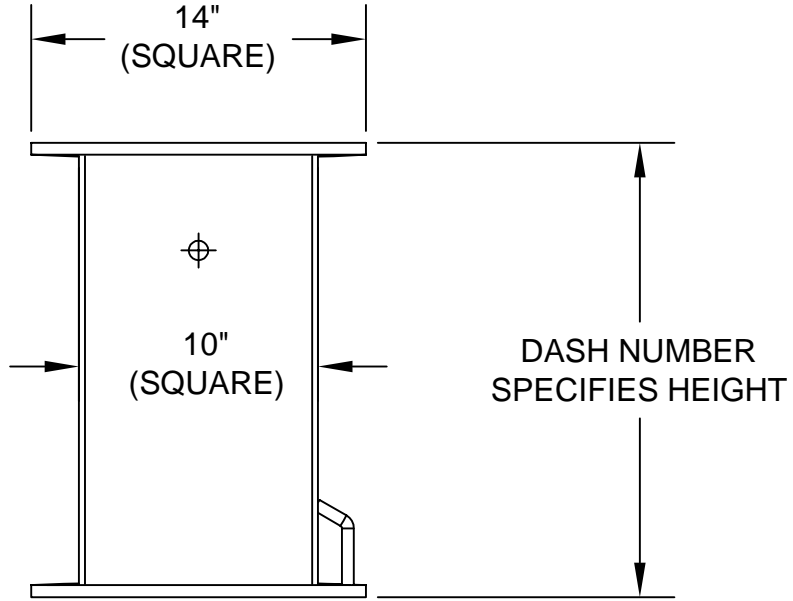

VENCO VENTURO INDUSTRIES LLC  
CINCINNATI, OHIO

TITLE  
21571 MNTNG PEDESTAL  
ET8/12 SERIES CRANES

DATE  
03-08-19D  
SUPERSEDES  
11-20-14C

SECTION  
C100  
21594



# SECTION 150

## SAFETY



VENCO VENTURO INDUSTRIES LLC  
CINCINNATI, OHIO

# CRANE SAFETY AND HAZARDS

## CAUTIONS

1. INSPECT VEHICLE AND CRANE, INCLUDING OPERATION, PRIOR TO USE DAILY.
2. DO NOT USE THIS EQUIPMENT EXCEPT ON FIRM LEVEL GROUND WITH CRANE MOUNTED ON FACTORY-RECOMMENDED TRUCK.
3. BEFORE OPERATING THE CRANE, REFER TO MAXIMUM LOAD (CAPACITY) CHART ON CRANE FOR OPERATING (LOAD) LIMITATIONS.
4. DO NOT OPERATE, WALK, OR STAND BENEATH BOOM OR A SUSPENDED LOAD.
5. ATTACH PENDANT CORD SUPPORT SNAP TO ATTACHMENT POINT BEFORE PLUGGING IN PENDANT, IF SO EQUIPPED.
6. UNPLUG PENDANT AND SHUT OFF MASTER DISCONNECT SWITCH WHEN CRANE IS NOT IN USE.
7. FOR TRAVEL, BOOM MUST BE IN STOWED POSITION.

## DANGER

- THIS CRANE IS NOT A PASSENGER LIFT
- IT IS NOT DESIGNED OR INTENDED TO BE USED TO LIFT, SUPPORT, OR OTHERWISE TRANSPORT PERSONNEL.

## YOU MUST NOT OPERATE THIS CRANE, UNLESS:

1. YOU HAVE BEEN TRAINED IN THE SAFE OPERATION OF THIS CRANE, AND
2. YOU KNOW AND FOLLOW THE SAFETY AND OPERATING RECOMMENDATIONS CONTAINED IN THE MANUFACTURER'S MANUALS, YOUR EMPLOYER'S WORK RULES, AND APPLICABLE GOVERNMENT REGULATIONS. AN UNTRAINED OPERATOR SUBJECTS HIMSELF AND OTHERS TO DEATH OR SERIOUS INJURY.

## ELECTROCUTION HAZARD

- THIS MACHINE IS NOT INSULATED.
- MAINTAIN SAFE CLEARANCES FROM ELECTRICAL LINES AND APPARATUSES.
- YOU MUST ALLOW FOR BOOM SWAY, ROCK, OR SAG, AND ELECTRICAL LINE AND LOAD-LINE SWAYING
- THIS LIFTING DEVICE DOES NOT PROVIDE PROTECTION FROM CONTACT WITH OR PROXIMITY TO AN ELECTRICALLY CHARGED CONDUCTOR.
- YOU MUST MAINTAIN A CLEARANCE OF AT LEAST 10 FEET BETWEEN ANY PART OF THE CRANE, LOAD-LINE, OR LOAD, AND ANY ELECTRICAL LINE OR APPARATUS CARRYING UP TO 50,000 VOLTS. REFER TO DRAWING 15394 FOR ADDITIONAL INFORMATION.
- **DEATH OR SERIOUS INJURY** WILL RESULT FROM CONTACT OR INADEQUATE CLEARANCES.

## OVERLOAD SENSING SYSTEM - STANDARD ON ALL CRANES

1. IF OVERLOADED, THE WINCH UP, BOOM DOWN, AND (OPTIONAL) BOOM OUT FUNCTIONS WILL AUTOMATICALLY, SHUT OFF TO PREVENT INCREASED OVERLOAD.
2. ON CRANES EQUIPPED WITH AN OPTIONAL OVERLOAD ALARM, IT WILL ALSO SOUND.
3. IF AN OVERLOAD OCCURS, USE THE WINCH DOWN, BOOM UP OR BOOM IN FUNCTIONS TO RELIEVE THE OVERLOAD.
4. THE OVERLOAD SENSING SYSTEM IS INOPERATIVE IF THE BOOM ELEVATION IS AT THE BOTTOM OR TOP LIMIT OF TRAVEL. TO RELIEVE THIS CONDITION, RAISE OR LOWER THE BOOM SLIGHTLY BEFORE LIFTING THE LOAD.
5. SEE MANUAL FOR TESTING THE OVERLOAD SYSTEM.

### NOTICE - WARRANTY VOID IF DISCONNECTED

THE OVERLOAD SENSING SYSTEM HAS BEEN INSTALLED AS A SAFETY FEATURE TO PROTECT THE EQUIPMENT AND THE OPERATOR.

DO NOT DISCONNECT THIS SYSTEM



VENCO VENTURO INDUSTRIES LLC  
CINCINNATI, OHIO

TITLE	DATE	SECTION
SAFETY & HAZARDS	01-29-15K	C150
ELECTRIC CRANES	SUPERSEDES 12-20-13J	850711

# CRANE SAFETY AND HAZARDS - CONT'D

## OVERLOAD ALARM SYSTEM - OPTIONAL

1. OVERLOAD ALARM HORN SOUNDS IF RATED LOAD IS EXCEEDED AT ANY REACH.
2. IF ALARM SOUNDS, RAISE BOOM OR LOWER WINCH TO REMOVE OVERLOAD.
3. ALWAYS RAISE BOOM SLIGHTLY BEFORE LIFTING LOAD. WARNING SYSTEM INOPERATIVE WHEN CYLINDER IS COMPLETED BOTTOMED.
4. ALARM CAN BE TESTED BY TYING DOWN BOOM WITH WINCH CABLE AND OPERATING BOOM UP OR BY RAISING BOOM AGAINST UP LIMIT STOP.

NOTICE - WARRANTY VOID IF DISCONNECTED

THIS ALARM SYSTEM HAS BEEN INSTALLED AS A SAFETY FEATURE TO PROTECT BOTH THE EQUIPMENT AND THE OPERATOR.

DO NOT DISCONNECT THIS SYSTEM

INTENTIONALLY LEFT BLANK



VENCO VENTURO INDUSTRIES LLC  
CINCINNATI, OHIO

TITLE	DATE	SECTION
SAFETY & HZRDS, CONT.	01-29-15	C150
ELECTRIC CRANES	SUPERSEDES -	850712

# VEHICLE & CRANE MOUNTED ELECTRICAL HAZARD SIGN APPLICATION & INFORMATION

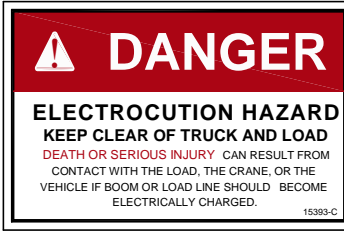

SIGN NO. 15393 DISPLAYS THE INTERNATIONAL SYMBOL FOR ELECTRICITY AND WARNS OF DANGER FROM AN ELECTRICALLY CHARGED VEHICLE, CRANE, OR LOAD. FOUR ARE RECOMMENDED (ONE FOR EACH SIDE AND ONE FOR EACH END OF VEHICLE) TO BE APPLIED IN LOCATIONS WHICH ARE READILY VISIBLE TO GROUND PERSONNEL.

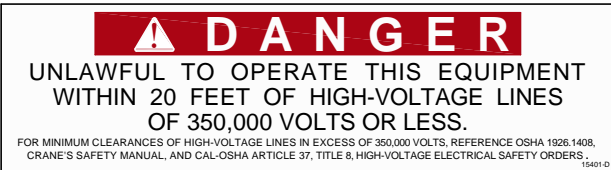

SIGN NO. 15401 PROVIDES ADDITIONAL WARNING OF LEGAL REQUIREMENTS WHEN OPERATING NEAR HIGH VOLTAGE LINES. THIS SIGN IS PLACED ON THE CONTROL PENDANT SIDE OF BOOM.

Table A - Minimum Clearance Distances

Voltage (nominal, kV, alternating current)	Minimum clearance distance (feet) *
Up to 50.....	10
over 50 - 200.....	15
over 200 - 350.....	20
over 350 - 500.....	25
over 500 - 750.....	35
over 750 - 1000.....	45
Over 1000.....	(as established by the utility owner/operator or registered professional engineer who is a qualified person with respect to electrical power transmission and distribution).

Table T - Minimum Clearance Distances While Traveling With No Load

Voltage (nominal, kV, alternating current)	While traveling - minimum clearance distance (feet) *
0 - 0.75.....	4
over 0.75 - 50.....	6
over 50 - 345.....	10
over 345 - 750.....	16
over 750 - 1000.....	20
Over 1000.....	(as established by the utility owner/operator or registered professional engineer who is a qualified person with respect to electrical power transmission and distribution).

\* NOTE: ENVIRONMENTAL CONDITIONS SUCH AS FOG, SMOKE, OR PRECIPITATION MAY REQUIRE INCREASED CLEARANCES



VENCO VENTURO INDUSTRIES LLC  
CINCINNATI, OHIO

TITLE	DATE	SECTION
HAZARD APPS & INFO	02-21-14M	C150
ET/HT CRANES	SUPERSEDES 12-20-13L	15394

DECAL #: 15390  
 DESCRIPTION: CAUTION, INSPECT VEHICLE & CRANE...  
 PURPOSE: TO INFORM THE OPERATOR OF KEY OPERATING REQUIREMENTS.  
 QUANTITY: 1  
 PLACEMENT: REAR COVER OR SIDE OF CRANE

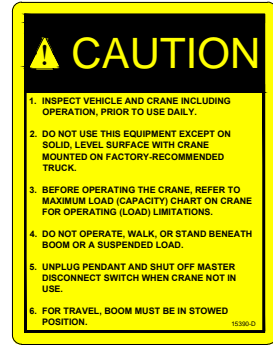

DECAL #: 15391  
 DESCRIPTION: DANGER, NOT A PASSENGER LIFT  
 PURPOSE: TO INFORM OPERATOR NOT TO LIFT, SUPPORT, OR TRANSPORT PERSONNEL, AND TO ENSURE OPERATOR IS ADEQUATELY TRAINED.  
 QUANTITY: 1  
 PLACEMENT: REAR COVER OR SIDE OF CRANE

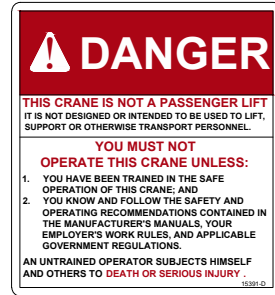

DECAL #: 15392  
 DESCRIPTION: DANGER, ELECTROCUTION HAZARD, MACHINE (CRANE)  
 PURPOSE: TO INFORM OPERATOR THAT MACHINE (CRANE) REPRESENTS AN ELECTROCUTION HAZARD SHOULD IT COME CLOSE TO OR IN CONTACT WITH AN ELECTRICAL VOLTAGE SOURCE.  
 QUANTITY: 1  
 PLACEMENT: REAR COVER OR SIDE OF CRANE



DECAL #: 15401  
 DESCRIPTION: DANGER, UNLAWFUL TO OPERATE  
 PURPOSE: TO INFORM OPERATOR OF PROPER OPERATION IN VICINITY OF ELECTRICAL LINES.  
 QUANTITY: 1  
 PLACEMENT: RING COVER OR SIDE OF CRANE

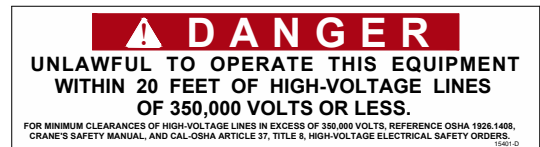

DECAL #: 15393  
 DESCRIPTION: DANGER, ELECTROCUTION HAZARD, VEHICLE (TRUCK)  
 PURPOSE: WARNS OF DANGER FROM ELECTRICALLY CHARGED VEHICLE, CRANE, OR LOAD.  
 QUANTITY: 4  
 PLACEMENT: EACH SIDE & EACH END OF VEHICLE

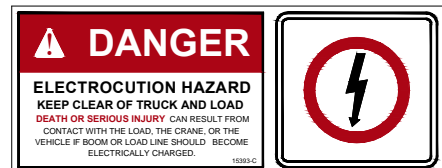

VENCO VENTURO INDUSTRIES LLC  
 CINCINNATI, OHIO

TITLE  
 SAFETY DECALS

VENTURO CRANES

DATE  
 04-29-16E

SUPERSEDES  
 10-24-13D

SECTION  
 C150

21353

PART NO.: 14473-2

DECAL: CONDUCTIVE GREASE

FUNCTION: To show the operator where to apply grease.

QUANTITY: Varies

PLACEMENT: Near grease fittings.



PART NO.: 13397

DECAL: OIL LEVEL

FUNCTION: To inform the operator of proper oil level to maintain.

QUANTITY: 1

PLACEMENT: Side of hydraulic power unit.

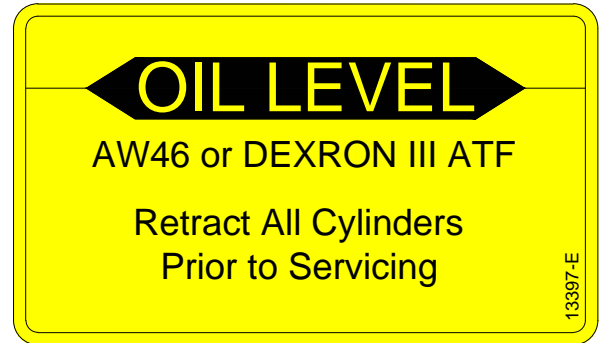

PART NO.: 15398

DECAL: UNPLUG REMOTE CONTROL

FUNCTION: To inform the operator to unplug remote control when not in use.

QUANTITY: 1

PLACEMENT: Near pendant socket.



MANUFACTURING, INC.  
CINCINNATI, OHIO

TITLE  
DECALS

ET CRANES

DATE  
11-12-19E

SUPERSEDES  
12-23-13D

SECTION  
C150

21354

PART NO.: 27007-03a (ET8) / 27007-04a (ET12)  
 DECAL: LOAD BLOCK CAPACITY DECAL  
 FUNCTION: To show the capacity of the load block.  
 QUANTITY: 2  
 PLACEMENT: Each side of load block.

27007-03a

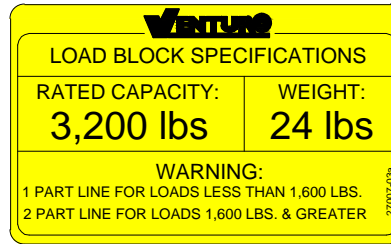

27007-04a

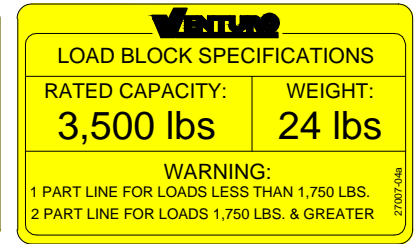

PART NO.: 17813  
 DECAL: OVERLOAD SENSING SYSTEM DECAL  
 FUNCTION: To advise operator of overload sensing system.  
 QUANTITY: 1  
 PLACEMENT: Location may vary.

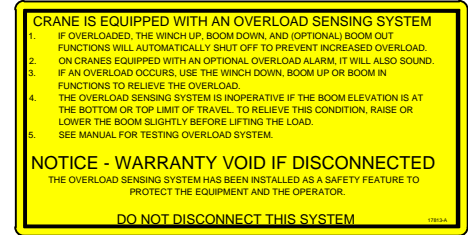

PART NO.: 14459 (WITH OPTIONAL ALARM)  
 DECAL: OVERLOAD ALARM SYSTEM DECAL  
 FUNCTION: To advise operator of alarm system.  
 QUANTITY: 1  
 PLACEMENT: Location may vary.

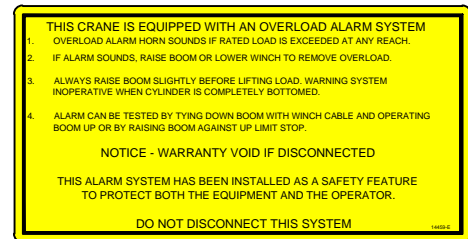

PART NO.: 28065 (RIGHT) & 23184 (LEFT)  
 DECAL: MANUAL OVERRIDE DECAL ET8/12KX(P)  
 FUNCTION: To show the manual override ports.  
 QUANTITY: 1  
 PLACEMENT: Right & Left side of housing.

28065



23184



INTENTIONALLY LEFT BLANK

INTENTIONALLY LEFT BLANK



VENCO VENTURO INDUSTRIES LLC  
 CINCINNATI, OHIO

TITLE  
 ADDITIONAL DECALS

ET8/12KX(P)

DATE  
 01-03-24A

SUPERSEDES  
 11-16-23

SECTION  
 C150

28545

PART NO.: 21576 (RIGHT) & 21577 (LEFT)

DECAL: CRANE CAPACITY

FUNCTION: To show the operator the operating capacities of crane.

QUANTITY: 1 each

PLACEMENT: One on each side of boom.

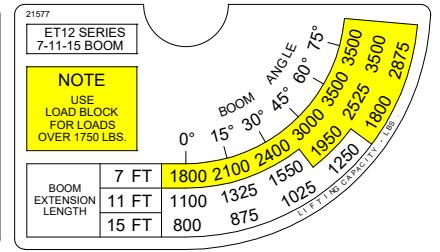
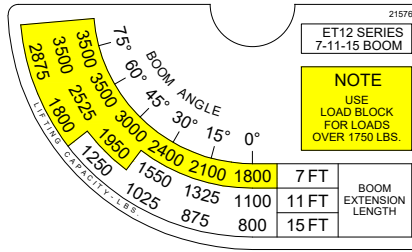

PART NO.: 28550

DECAL: MODEL ET12KX-15'

FUNCTION: To show model of crane.

QUANTITY: 2

PLACEMENT: One on each side of boom.



INTENTIONALLY LEFT BLANK

INTENTIONALLY LEFT BLANK

INTENTIONALLY LEFT BLANK



MANUFACTURING, INC.  
CINCINNATI, OHIO

TITLE  
MODEL/CAPCTY DECALS

ET12-15' SERIES

DATE  
11-15-23

SUPERSEDES  
-

SECTION  
C150

28551



# SECTION 200

# INSTALLATION



VENCO VENTURO INDUSTRIES LLC  
CINCINNATI, OHIO

# !! IMPORTANT !!

## ADEQUATE WIRING IMPERATIVE FOR PROPER OPERATION

1. PROPER GROUND PATH - SEE DWG 15660
2. CURRENT DRAW IS SEVERAL HUNDRED AMPERES - ADEQUATE WIRE SIZE AND BATTERY CAPACITY IS ABSOLUTELY ESSENTIAL (SEE CHART BELOW).

### ▲ MINIMUM WIRE GAUGE AND AUXILIARY BATTERY SIZE

MODEL	TOTAL LENGTH OF CABLE (FT) *								▲ 12 VOLT AUXILIARY BATTERY REQUIREMENTS	
	0-20	21-25	26-30	31-40	41-50	51-60	61-70	71-80	CCA (A) **	RC (MIN) ***
▲ CE1500 CE6K CT2000 CT2003/4/5 DT7K	#4	#4	#2	#2	#1	#0	#0	#00	350	100
ET5500MPB ET5500R ET6KMPB ET6KR ET6K ET8K ET10K ET12K	#2	#2	#1	#0	#00	NOT RECOMMENDED			450	100
ET8KX ET10KX ET12KX ▲ ET12KXP	#2	#2	#1	#0	#00	NOT RECOMMENDED			550	150
ET18K(X) ET25K(X) ET30KX ET36KX	SEE DRAWING 15660 FOR CABLE AND BATTERY REQUIREMENTS									

\* INCLUDES GROUND CABLE

\*\* CCA = COLD CRANKING AMPS AT 0° (F).

\*\*\* RC = RESERVE CAPACITY IN MINUTES AT 25 AMPS AND 80° (F).  
THE RC RATING IS A MEASURE OF THE PERIOD OF TIME THE BATTERY CAN SUPPLY A GIVEN CURRENT WITHOUT RECHARGING.



VENCO VENTURO INDUSTRIES LLC  
CINCINNATI, OHIO

TITLE  
CABLE & BATTERY

DATE  
07-30-18X

SECTION  
C200

ELECTRIC CRANES

SUPERSEDES  
09-27-17W

**711105**

**RECOMMENDED CIRCUIT BREAKER TABLE**

CRANE	DESCRIPTION	PART NO.
CT310KX	250 AMP, MAN RESET	22946-250
DT7	250 AMP, MAN RESET	22946-250
CE-1500-FB	150 AMP, MAN RESET	22946-150
CE6K	150 AMP, MAN RESET	22946-150
CT200X	250 AMP, MAN RESET	22946-250
ET6K	250 AMP, MAN RESET	22946-250
ET8/12K(X)	250 AMP, MAN RESET	22946-250
ET12KXP	300 AMP, MAN RESET	22946-300
ET16/18KX-16'	250 AMP, MAN RESET	22946-250
ET16/18KX-20'	300 AMP, MAN RESET	22946-300
ET25/30KX	300 AMP, AUTO RESET	22946-300
ET36KX	300 AMP, AUTO RESET	22946-300

**BATTERY REQUIREMENTS**

- 12 VOLT VEHICLE BATTERY REQUIREMENTS
  - 625 COLD CRANKING AMPS (AT 0° F)
  - 160 MINUTES RESERVE CAPACITY
  - 102 PLATES, 105 AMP-HR
- (1) ● 12 VOLT AUXILIARY BATTERY REQUIREMENTS
  - SEE MINIMUM WIRE GAUGE AND BATTERY SIZE

**NOTE: OPERATING WITH THE VEHICLE BATTERY 'ONLY' IS PERMISSIBLE, BUT NOT RECOMMENDED.**

**RECOMMENDED BATTERY TERMINAL ATTACHMENT**

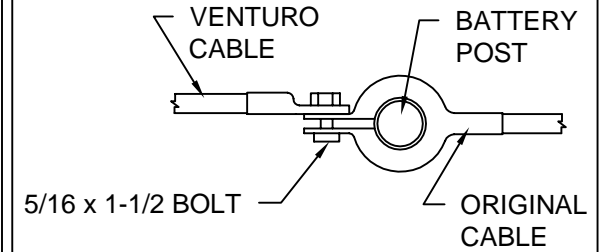

**INSTALL #2 GAUGE GROUND STRAP FROM ENGINE TO TRUCK FRAME (REQUIRED IF NEGATIVE FROM BATTERY IS CONNECTED TO ENGINE)**

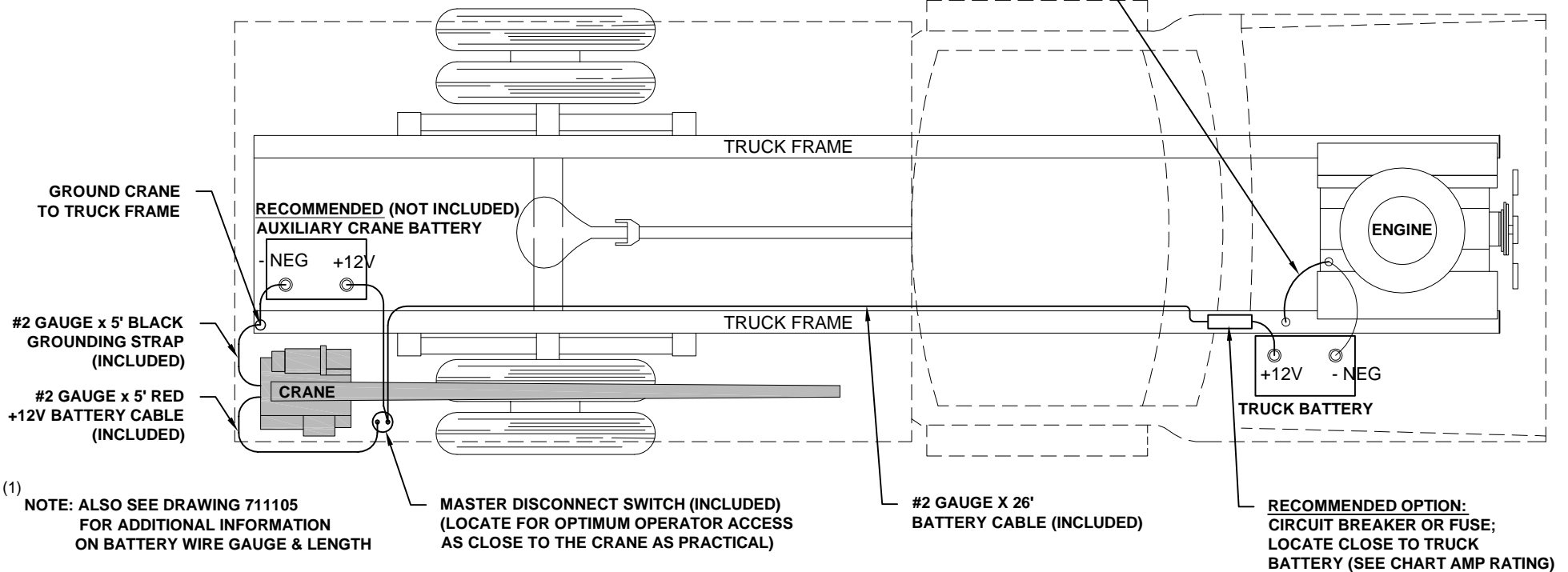

(1) NOTE: ALSO SEE DRAWING 711105 FOR ADDITIONAL INFORMATION ON BATTERY WIRE GAUGE & LENGTH



VENCO VENTURO INDUSTRIES LLC  
CINCINNATI, OHIO

TITLE

BATTERY CABLE & COMPONENT INSTALL

ET CRANES

DATE

09-03-20M

SUPSEDES

07-30-18L

SECTION

C200

15660

# STABILITY TEST - ET12-15' SERIES

## Overview

Venturo follows the guidelines of ANSI B30.5 in defining stability. Generally speaking, a truck is considered stable as long as it is not on the verge of tipping - i.e. with the truck level, at least one tire on each corner of the truck must remain in contact with the ground.

It is important to note that nearly every installation is unique and will, therefore, typically require stability testing.

The procedure outlined below follows ANSI's (B30.5 - 5-1.1.1) specified "maximum load rating" of 85% of truck stability.

## Testing Procedure

1. Locate the truck on firm, level ground and set parking brake.
2. Fully deploy stabilizers, making sure they are firmly in contact with supportive ground; use stabilizer pads as required. The tires of the truck should remain in full contact with the ground.
3. Inspect wire rope and other key components of crane (consult owners manual for more information).
4. Conduct an operational check of all crane functions.
5. Locate the Overload Pressure Switch at the base of the elevation cylinder
  - 5.1. Disconnect the black & white wires from the housing and then connect the black & white wires together to by-pass the Overload Pressure Switch for the stability test. **Note: The black & white wires MUST be reconnected to the Overload Pressure Switch after the stability test has been completed.**
6. Use a **Test Weight** weighing a **minimum** of **941 lbs.**, (includes load block weight of 24 lbs.) to a **maximum of 1000 lbs.**
7. Position the boom level and fully retracted.
8. Referring to the Stability Chart (drawing 20907) rotate the crane to a position between 1 and 2 o'clock (truck cab is facing 12 o'clock) to begin testing.
9. Use the winch to lift the Test Weight; DO NOT allow the weight to be more than 6" off the ground at any time during testing (for safety).
10. Using the test weight, extend the boom slowly, until one of two conditions occur:
  - 10.1. Full extension is reached - Mark the ZONE in question 100%
  - 10.2. The truck becomes unstable i.e., a tire lifts off the ground
    - 10.2.1. Retract the boom until at least one tire on each corner of the truck is making contact with the ground
    - 10.2.2. Use the formula below to determine the allowable **% of Rated Capacity** for the ZONE in question:
11. Note: The "**Max Stable Reach in inches**" is measured (horizontally) from the **center of rotation** of the crane housing to the **lifting load hook**.
$$\% \text{ Rated Capacity} = \frac{\text{"Max Stable Reach" in inches}}{184} \times 100$$
12. Record the **% of Rated Capacity** in the appropriate blank (region) on the Crane Stability page (ref. 20907) and decal.
13. Repeat Steps 7 through 12 for each ZONE on the stability page.



VENCO VENTURO INDUSTRIES LLC  
CINCINNATI, OHIO

TITLE

STABILITY TEST

ET12-15' SERIES

DATE

03-16-23H

SUPERSEDES

11-23-21G

SECTION

C200

20906-12

# CRANE STABILITY

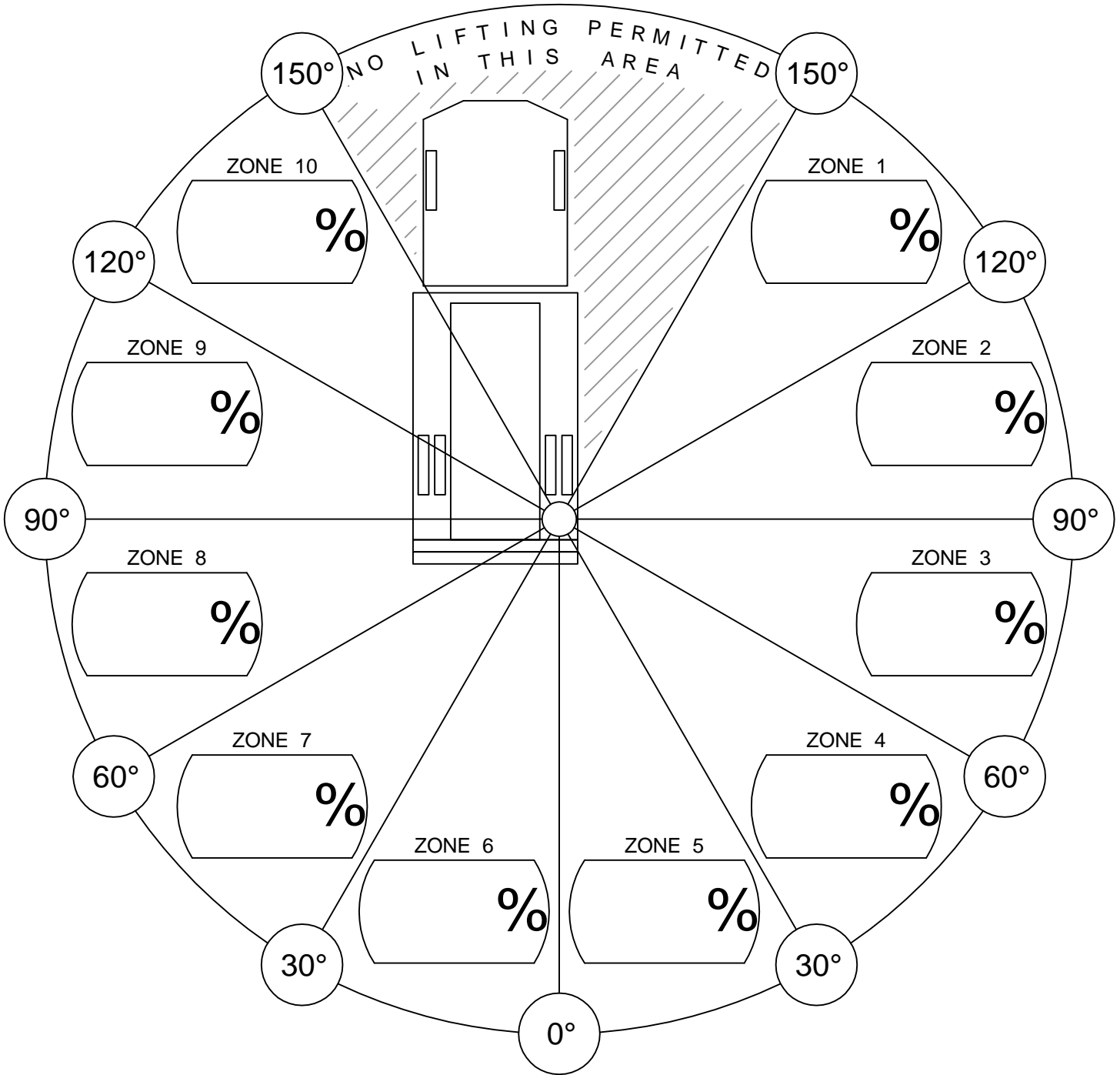

% of Rated Capacity for each of the 10 regions are provided above.

**CONDITIONS:**

- STABILIZERS FULLY EXTENDED & DOWN, ON FIRM LEVEL GROUND.



VENCO VENTURO INDUSTRIES LLC  
CINCINNATI, OHIO

TITLE  
**STABILITY CHART**

VENTURO CRANES

DATE  
05-11-17F

SUPERSEDES  
02-21-14E

SECTION  
C200

**20907**

# WIRE ROPE INSTALLATION

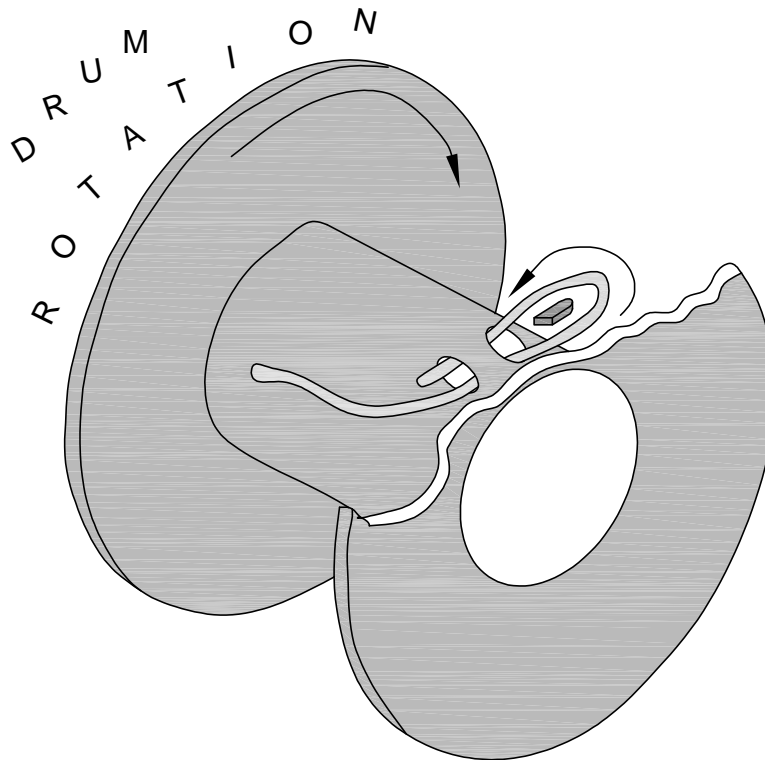

FIG. 1

- STEP 1: UNWIND COIL OF WIRE ROPE BY 'ROLLING' ALONG THE FLOOR. THIS WILL PREVENT 'KINKING'.
- STEP 2: INSERT WIRE ROPE END UP THROUGH ANTI-2-BLOCK (A2B) CAGE ASSEMBLY, BETWEEN CHEEK PLATES, OVER THE TOP SHEAVE, AND THROUGH WIRE ROPE GUIDE.
- STEP 3: INSERT WIRE ROPE END INTO POCKET OPENING ON WINCH, WRAP AROUND WEDGE, AND BACK THROUGH POCKET OPENING AS SHOWN IN FIGURE 1.



## CAUTION

- IF THE WIRE ROPE IS NOT INSTALLED FOR THE CORRECT DRUM ROTATION, THE WINCH BRAKE VALVE WILL NOT HOLD THE LOAD.



## CAUTION

- THERE MUST ALWAYS BE AT LEAST [5] DEAD WRAPS OF WIRE ROPE ON THE WINCH DRUM WHILE UNDER LOAD.

NOTE: SOME WINCHES MAY BE SUPPLIED WITH A HEX NUT IN LIEU OF A WEDGE FOR INSTALLING THE WIRE ROPE.



VENCO VENTURO INDUSTRIES LLC  
CINCINNATI, OHIO

TITLE

WIRE ROPE INSTALLTN

DATE

02-21-14K

SECTION

C200

ET6K & LARGER CRANES

SUPERSEDES

12-26-13J

22245

# 21440 ADJUSTABLE BOOM REST

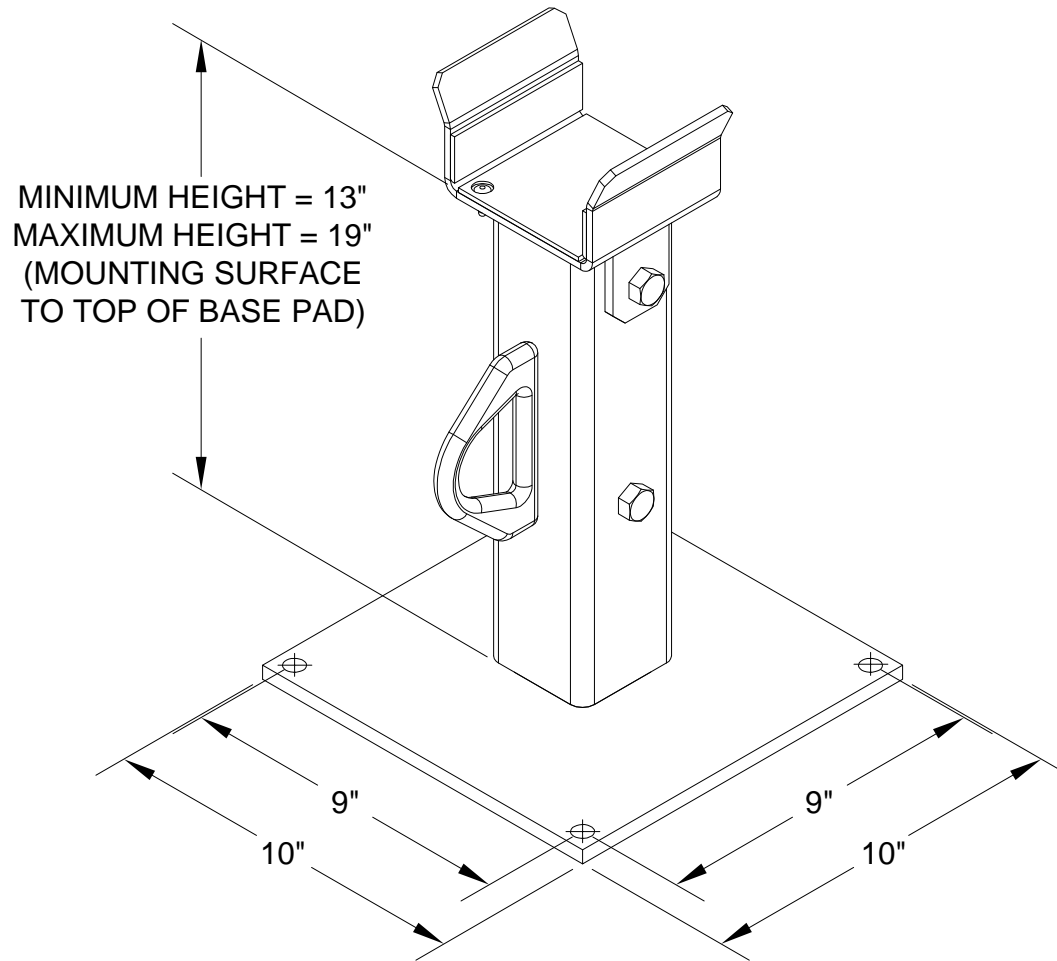

VENCO VENTURO INDUSTRIES LLC  
CINCINNATI, OHIO

TITLE  
21440 ADJUSTABLE BOOM REST

ET6/8/12 SERIES CRANES

DATE  
03-08-19B

SUPERSEDES  
12-26-13A

SECTION  
C200

20872

**SECTION 300**

**MAINTENANCE**

**&**

**SERVICE**



VENCO VENTURO INDUSTRIES LLC  
CINCINNATI, OHIO



# CRANE OPERATION AND MAINTENANCE INSTRUCTIONS

## SAFETY

Before operating this crane, read and understand these instructions, the "CRANE SAFETY AND HAZARDS" pages, and review all safety and instruction labels on the crane.

## CRANE INSPECTION

Before operating this crane, inspect for wear, damage, and oil leakage. After the wire rope has been run out, check for wear, kinks, and broken strands. Check the hook and safety latch for damage. Correct problems before using the crane.

## CAPACITY

Before operating this crane, review the capacity charts on the sides of the boom to relate the load to be lifted to the boom length and angle. The boom angle is indicated by a gravity arrow.

## LOAD BLOCK

If the load exceeds:

1000 lbs. for the ET6K, or

1600 lbs. for the ET8 Series and ET10K(X), or

1750 lbs. for the ET12 Series,

or if reduced winching speed for better control of smaller loads is required, use the load block to rig the crane for two-part line operation. Refer to your crane's "MAXIMUM LOAD CAPACITY" page within this manual.

## CONTROLS

This crane is operated by a remote control pendant. The pendant should be unplugged and stored in a compartment or the cab when the crane is not in use.

Before plugging the pendant in, inspect the plug, socket, cord, pendant head, and switches for damage. Actuate all switches in both directions to verify that they all have the same feel and sound, and that they return to the center position.

Plug the pendant into the socket on the right side of the crane and, if applicable, snap the strain relief tether to the crane housing.

Turn on the Master Disconnect Switch. Use "WINCH DOWN" to release tension on the wire rope and unhook it from the storage tie-down position.

Use "BOOM UP" to elevate the boom from the boom rest position.

Check all control functions to see that they are working correctly.



VENCO VENTURO INDUSTRIES LLC  
CINCINNATI, OHIO

TITLE	DATE	SECTION
INSTALLATION DWG	06-22-23K	C200
ET6/8/12 SERIES CRANES	SUPERSEDES 03-08-19J	900530A

# CRANE OPERATION AND MAINTENANCE INSTRUCTIONS

## CONTROL FUNCTIONS

WINCH UP and WINCH DOWN - Raises and lowers the load with the wire rope.

POWER EXTENSION - "Up" raises the boom elevation by operating the valves and the electric hydraulic power unit. "DOWN" operates a solenoid release valve mounted on the cylinder to lower the load and/or boom by gravity at a controlled rate. A check valve on the cylinder prevents the boom from coming down if a hose breaks. A flow control valve controls the lowering rate.

POWER ROTATION - "L" and "R" control the direction of rotation. The ET6K, ET8K(X), ET10K(X) or ET12K(X) can be rotated continuously thru 360° or more. There are no restrictions on the number of rotations in any direction.

CONTROL PRIORITY SYSTEM (NON-PROPORTIONAL SYSTEMS) - As a built in safety feature, the operator can perform only one major and one minor function at any one time. Major functions include rotation, winching up of a load, and elevating, extending, and retracting the boom. Minor functions include winching down and lowering the boom.

- a. "WINCH UP" has priority over "BOOM UP", "BOOM OUT", "BOOM IN", and "ROTATION."
  - b. "BOOM UP" has priority over "BOOM OUT", "BOOM IN", and "ROTATION."
  - c. "BOOM OUT" and "BOOM IN" have priority over "ROTATION."
  - d. "BOOM DOWN" and "WINCH DOWN" can be operated with any function.
- ▲ TRIGGER (ET12KXP Only) - Varies the flow rate delivered to the crane valve. The farther the trigger is pulled, the faster the selected crane function operates.

## OVERLOAD SENSING SYSTEM

This crane is equipped with an Overload Sensing System. If the capacity of the crane is exceeded, the "Winch Up", "Boom Down", and "Boom Out" functions will be shut down. The "Winch Down", "Boom Up", and "Boom In" functions will continue to operate and can be used to relieve the overload condition. The "Rotation" function also will continue to operate.

## TWO-BLOCK SENSING SYSTEM

- This crane is equipped with an anti two-block device that is mounted at the tip of the boom. If the load block / overhaul weight contacts the device the "Winch Up", "Boom Down", and "Boom Out" functions are disabled. The "Winch Down", "Boom Up", and "Boom In" functions will continue to operate and can be used to relieve the two-block condition.
- ▲

## CRANE OPERATION

Avoid rapid reversal of the winch and rotation control switches. The high inrush current to the motors during reversal can reduce the life of the contactors, motor brushes, and commutators.

When operating "WINCH UP", "BOOM DOWN", or "BOOM OUT," always maintain clearance between the boom head and the load block or hook.

Do not lift or drag a load sideways using any of the crane functions. The boom has much lower bending strength sideways than in a vertical direction.



VENCO VENTURO INDUSTRIES LLC  
CINCINNATI, OHIO

TITLE

INSTALLATION DWG

DATE

03-08-19H

SECTION

C200

▲  
ET6/8/12 SERIES CRANES

SUPERSEDES

07-30-18G

900530B

# CRANE OPERATION AND MAINTENANCE INSTRUCTIONS

## OVERLOAD ALARM SYSTEMS (OPTIONAL)

This crane may be equipped with an optional overload alarm system.

1. Overload alarm horn sounds if rated load is exceeded at any reach.
2. If alarm sounds, RAISE boom or LOWER winch to remove overload.
3. Always RAISE boom slightly before lifting load - warning system INOPERATIVE when cylinder is completely bottomed.
4. Alarm can be tested by raising boom against up limit stop.

## MANUAL TELESCOPIC BOOM

The 6' -14' and 7' - 15' booms have a 4' manual telescoping section in addition to the 4' power extension. A toggle pin locks the boom into either the extended or retracted position.

## TRUCK SETUP & STABILIZERS

1. The truck should be parked on firm level ground when using the crane.
2. The center of the crane should be positioned close enough to the job so that it can be operated at a reach that puts the load within the rated capacity of the crane.
3. Set the vehicle parking brake and put the vehicle transmission in "park" (automatic transmission) or low gear (manual transmission), unless the engine is to be left running.
4. Deploy the stabilizers to stabilize the vehicle against rocking or overturning when lifting with the crane.

## PREPARATION FOR TRAVEL

1. Return the stabilizers to the stowed position. Install and secure all pins.
2. Stow the crane boom in the boom support.
3. Hook the winch line to a tie down point on the body or pedestal and apply tension.
4. TURN OFF MASTER DISCONNECT SWITCH.
5. Unplug the control pendant and store in a body compartment or the cab.



## WARNING

- The pendant (or receiver) plug must be unplugged from the crane socket and the Master Disconnect Switch (power) turned "OFF" when the crane is not in use! Leaving the pendant (or receiver) connected and power on when not in use may result in dangerous, unintentional activation of the crane functions.



MANUFACTURING, INC.  
CINCINNATI, OHIO

TITLE  
INSTALLATION DWG  
ET6/8/10/12 SERIES

DATE  
03-08-19F  
SUPERSEDES  
12-26-13E

SECTION  
C200  
900530C

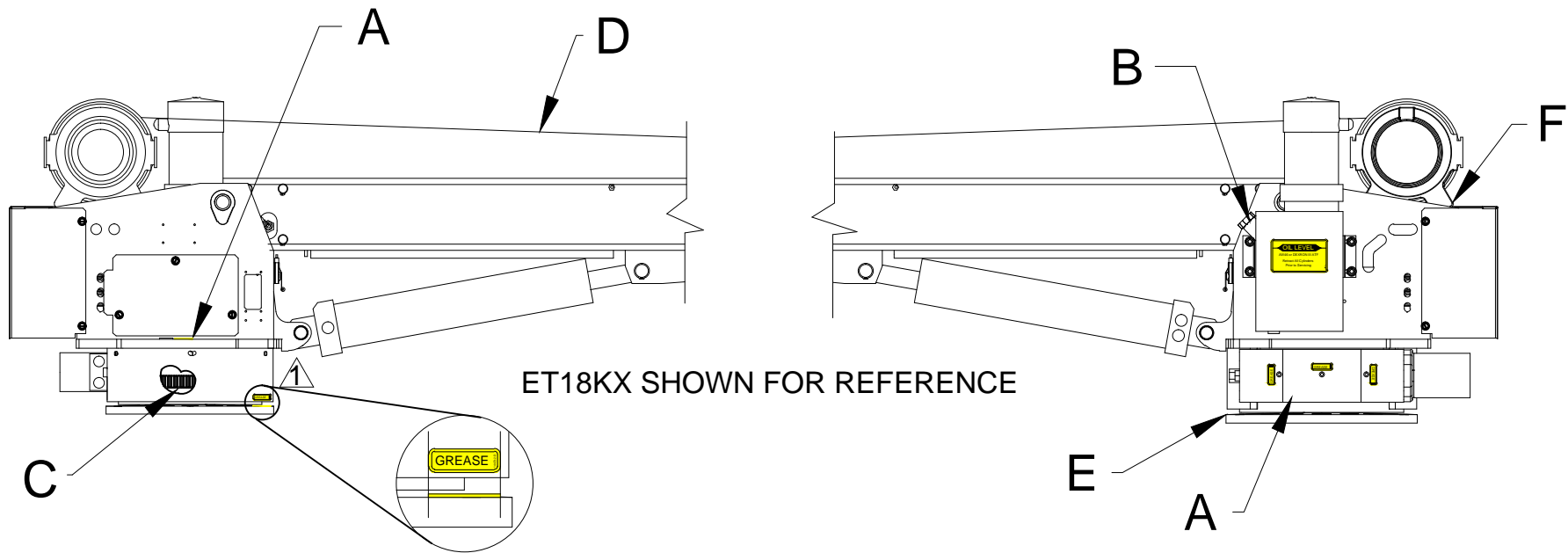

**ATTENTION:**

NEVER WASH THIS CRANE WITH CHEMICAL PRODUCTS OR HIGH PRESSURE WATER JETS, AS THEY CAN CAUSE DETACHMENT OF DECALS OR ENTRANCE OF WATER INTO ELECTRICAL OR SLEWING RING COMPONENTS

Location	Service Required	Note		Service Interval
A	Grease fitting With Pressure Grease Gun	Use FUCHS Renolit Aluminum Complex Grease, or equivalent ⚠️ ALIGNMENT: To align hole w/ fitting, line up grease decals on lower cover and base gusset.		Time of Truck Service
B	Fill Oil Reservoir to Oil Level with Boom Down and Boom In.	Use Dextron ATF for Ambient Temperatures Between -22° F and 30° F	Use ISO Viscosity Grade 68 or Equivalent for Ambient Temperatures Between 10°F and 125°F	Time of Truck Service and as required by changes in the ambient temperature range
C	Lubricate Gear Teeth	Remove Cover & Use Chassis Grease		Time of Truck Service
D	Check Wire Rope and Hook	Rope should be free of kinks and fraying		Time of Truck Service
E	Check Torque of Base Mounting Bolts	Square Base: Torqued to 200 ft-lbs		Time of Truck Service
-	Check Torque of Base Mounting Bolts	Rectangular Base: Torqued to 455 ft-lbs		Time of Truck Service
F	Check Torque of Winch Mounting Bolts	Bolts should be torqued to 35 ft-lbs*		Time of Truck Service

\* 32 FT-LBS. FOR ET8/12 WITH GTD-2200 COMEUP WINCH. SEE PAGE 21741 FOR WINCH IDENTIFICATION.



VENCO VENTURO INDUSTRIES LLC  
CINCINNATI, OHIO

TITLE

LUBRICATION & MAINTENACE CHART

DATE

03-06-23L

SECTION

C300

ET8/12/16/18 SERIES CRANES

SUPERSEDES

01-30-23K

21306

# MINIMUM VOLTAGE TEST

ONE OF THE MOST COMMON ELECTRICAL PROBLEMS ENCOUNTERED ON 12 VOLT ELECTRICAL CRANES IS INSUFFICIENT VOLTAGE AT THE MOTOR WHEN DRAWING THE LARGE CURRENT THAT EXISTS AT FULL LOAD

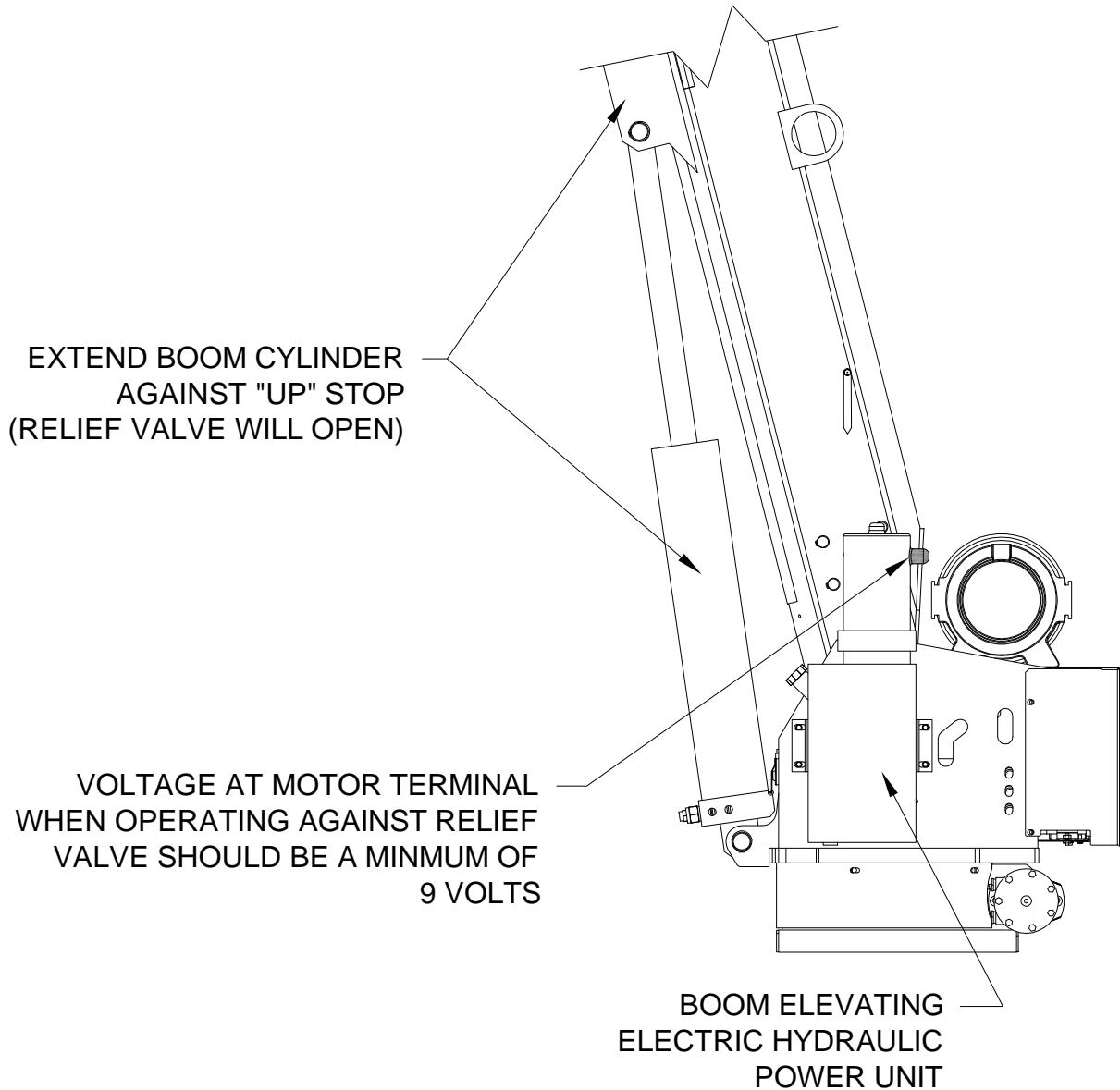

MANUFACTURING, INC.  
CINCINNATI, OHIO

TITLE  
**MINIMUM VOLTAGE TEST**  
ET SERIES CRANES

DATE  
12-26-13G  
SUPERSEDES  
10-05-09F

SECTION  
C300  
**19963**

## WIRE ROPE ASSEMBLY

### ET6K WIRE ROPE:

3/16" DIA, 50' LONG

GAC 7X19 LHRL-IWRC, SB 4200 LBS

### ▲ ET8/12 SERIES WIRE ROPE:

1/4" DIA, 65' LONG

GAC 7X19 IPS-LHRL-IWRC, SB 7000 LBS

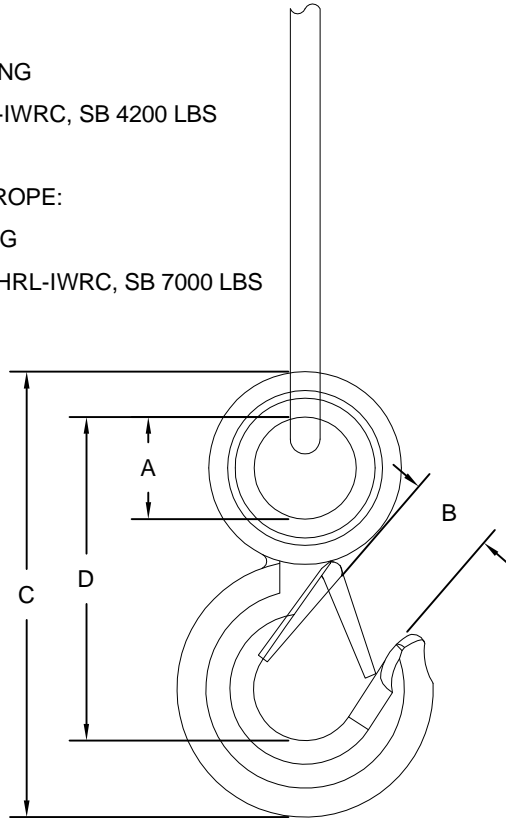

### WIRE ROPE HOOK:

RATING: 1 TONNE (2205 LBS)

### DIMENSIONS:

A	B	C	D
0.88"	1.06"	4.88"	3.63"

## LOAD BLOCK ASSEMBLY

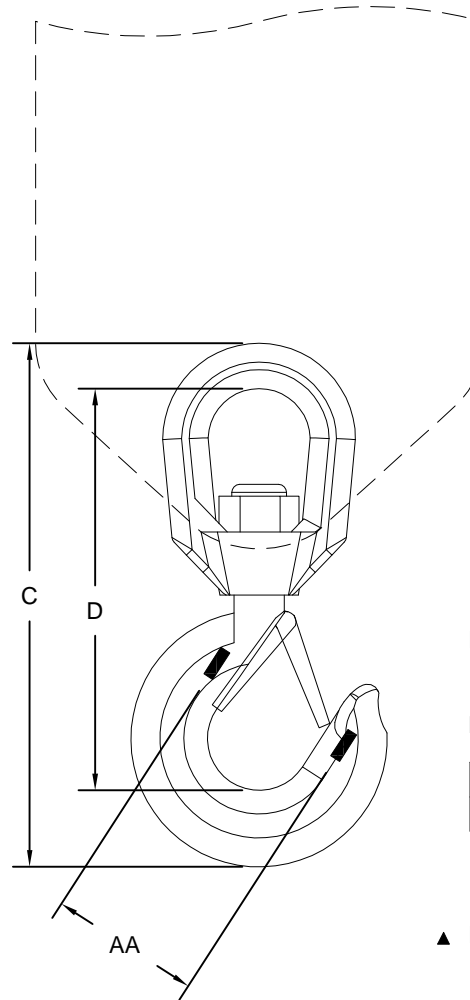

### ET6K LOAD BLOCK HOOK:

RATING: 1.5 TONNE (3307 LBS)

### DIMENSIONS:

COLOR	BRAND	AA	C	D
GOLD	CROSBY	2.00"	7.75"	6.12"

### ▲ ET8/12 SERIES LOAD BLOCK HOOK:

RATING: 2 TONNE (4410 LBS)

### DIMENSIONS:

COLOR	BRAND	AA	C	D
GOLD	CROSBY	2.00"	8.25"	6.50"



VENCO VENTURO INDUSTRIES LLC  
CINCINNATI, OHIO

TITLE

WIRE ROPE & HOOKS SPECIFICATIONS

▲ ET6/8/12 SERIES CRANES

DATE

03-08-19G

SUPERSEDES

05-09-16F

SECTION

C300

23225

MANUAL OVERRIDE INSTRUCTIONS  
 ET NON-PROPRIONAL SERIES CRANES ▲

!! READ ALL INSTRUCTIONS BEFORE PERFORMING MANUAL OVERRIDE PROCEDURES !!

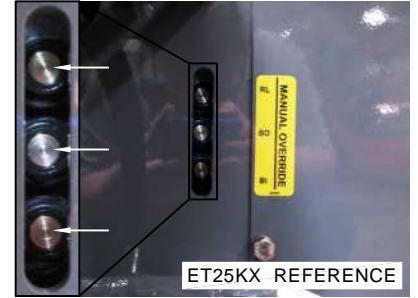

Each valve station incorporates [2] hydraulic ports and [2] coils. Manual override shafts are located in the center of the coils (see figure 1). Manual override decals are placed on each crane near the valve assembly. These decals provide a visual aid that helps the operator determine the function designations (Reference figure 2).

2-STATION FUNCTIONS:

RR = Rot. Right    RL = Rot. Left  
 BU = Boom Up    BD = Boom Down

3-STATION FUNCTIONS include previous functions, plus:

BI = Boom In    BO = Boom Out

**ALWAYS BE SURE TO CHECK HYDRAULIC OIL LEVEL BEFORE PROCEEDING. IT IS RECOMMENDED TO REMOVE ANY ITEM(S) THAT MAY INTERFERE WITH OPERATING THE CRANE MANUALLY. IF POSSIBLE, STRAPS AND/OR HARNESSSES SHOULD BE REMOVED BEFORE OPERATING A CRANE IN MANUAL OVERRIDE !!**

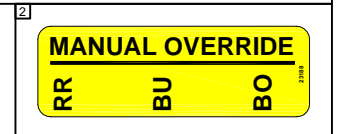
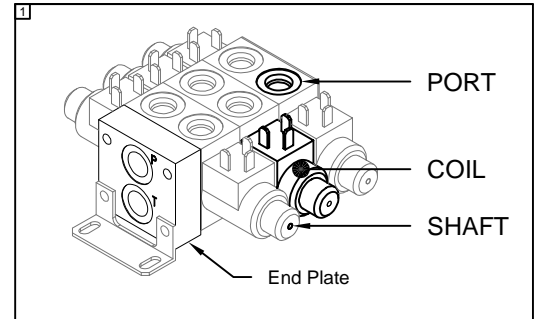

Procedure:

1. Turn Master disconnect switch to "ON"
2. Power up the pendant / radio
  - 2.1. PENDANT - twist EMERGENCY STOP button clockwise
  - 2.2. RADIO - Press green ON button
3. On the crane, reference the function you wish to perform using the manual override decal
4. Using a tool with a diameter of 1/8" or smaller, press the shaft inward and hold
5. Reference the functions listed on your pendant or radio (see figure 3)
6. Press the switch or button for the same function
7. If you need to change function,
  - 7.1. Release switch or button
  - 7.2. Remove tool from shaft
  - 7.3. Go to step 3

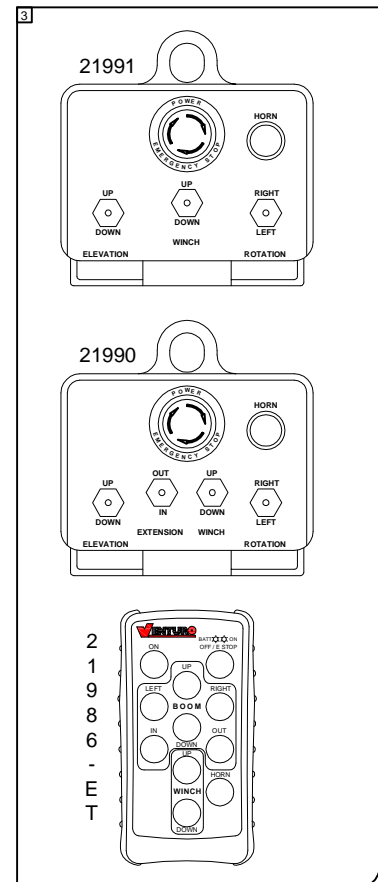

For assistance, please feel free to contact Technical Support at 800-226-2238.



VENCO VENTURO INDUSTRIES LLC  
 CINCINNATI, OHIO

TITLE  
**MAN. OVERRIDE INSTR.**  
 ▲  
 ET NON-PROP CRANES

DATE  
**03-08-19A**  
 SUPERSEDES  
**02-09-17**

SECTION  
**C200**  
**23084**

MANUAL OVERRIDE INSTRUCTIONS  
ET PROPRTIONAL SERIES CRANES ▲

!! READ ALL INSTRUCTIONS BEFORE PERFORMING MANUAL OVERRIDE PROCEDURES !!

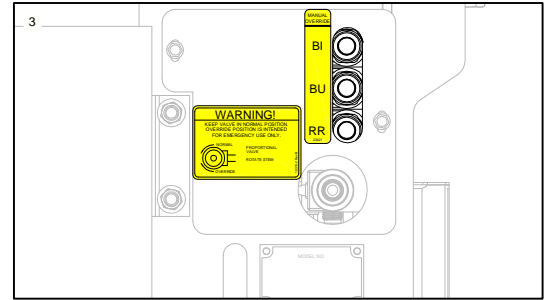
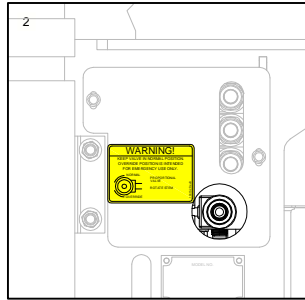
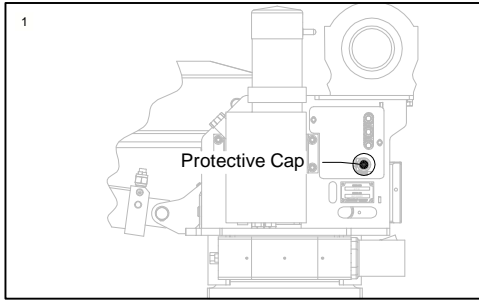

Each valve station incorporates [2] hydraulic ports and [2] coils. Manual override shafts are located in the center of the coils (see figure 4). Manual override decals are placed on each crane near the valve assembly. These decals provide a visual aid that helps the operator determine the function designations (Reference figure 3 & 5).

3-STATION FUNCTIONS:

- |                 |                |
|-----------------|----------------|
| RR = Rot. Right | RL = Rot. Left |
| BU = Boom Up    | BD = Boom Down |
| BI = Boom In    | BO = Boom Out  |

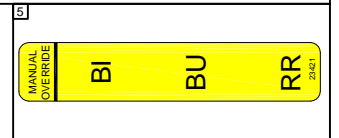
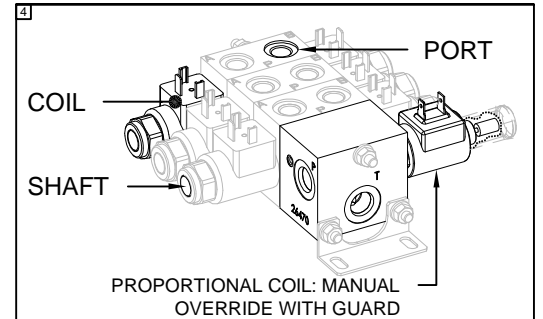

**ALWAYS BE SURE TO CHECK HYDRAULIC OIL LEVEL BEFORE PROCEEDING. IT IS RECOMMENDED TO REMOVE ANY ITEM(S) THAT MAY INTERFERE WITH OPERATING THE CRANE MANUALLY. IF POSSIBLE, STRAPS AND/OR HARNESES SHOULD BE REMOVED BEFORE OPERATING A CRANE IN MANUAL OVERRIDE !!**

Procedure:

1. Turn Master disconnect switch to "ON"
2. Remove Protective cap (see figure 1)
3. Rotate Valve Stem Clockwise to close (see figure 2)
4. Power up the pendant / radio
  - 4.1. Twist EMERGENCY STOP button clockwise
5. On the crane, reference the function you wish to perform using the manual override decal (see figure 3)
6. Using a tool with a diameter of 1/8" or smaller, press the shaft inward and hold
7. Reference the functions listed on your pendant or radio (see figure 6)
8. Press the switch or button for the same function
9. If you need to change function,
  - 9.1. Release switch or button
  - 9.2. Remove tool from shaft
  - 9.3. Go to step 5

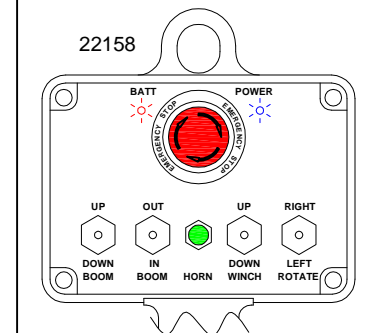
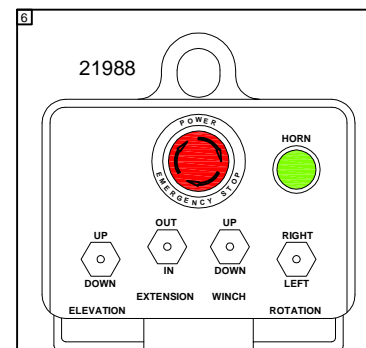

For assistance, please feel free to contact Technical Support at 800-226-2238.



VENCO VENTURO INDUSTRIES LLC  
CINCINNATI, OHIO

TITLE  
MAN. OVERRIDE INSTR.  
ET PROPORTIONAL CRANES

DATE  
03-08-19A  
SUPERSEDES  
07-30-18

SECTION  
C200  
23775



# SECTION 400

# REPLACEMENT PARTS



VENCO VENTURO INDUSTRIES LLC  
CINCINNATI, OHIO

# REPLACEMENT PARTS DRAWING; ET8 (14') & ET12 (15'), MECHANISM

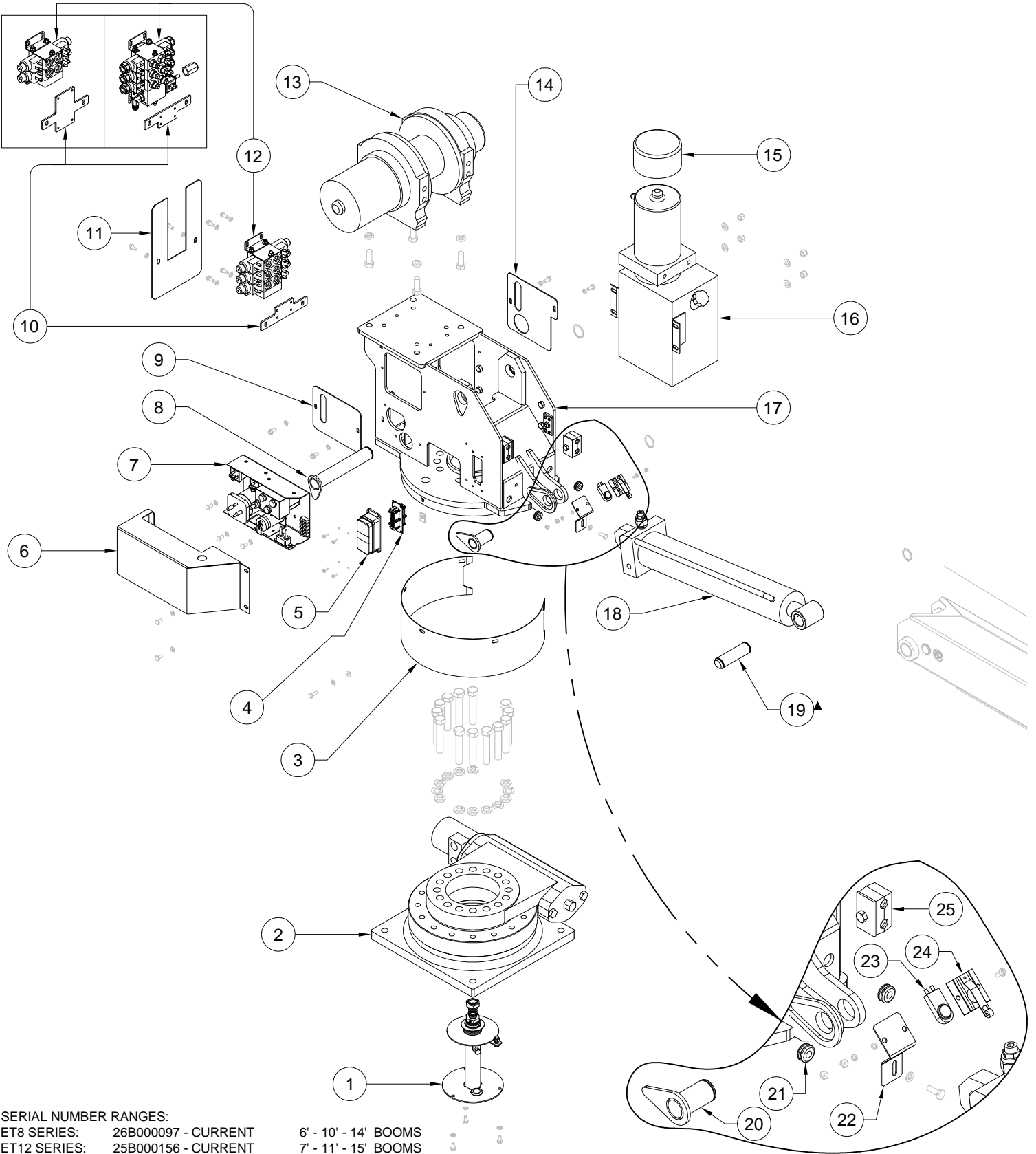

SERIAL NUMBER RANGES:  
 ET8 SERIES: 26B000097 - CURRENT 6' - 10' - 14' BOOMS  
 ET12 SERIES: 25B000156 - CURRENT 7' - 11' - 15' BOOMS

REFERENCE DWG #28064 FOR REPLACEMENT PARTS LIST

ET12KX SHOWN FOR REFERENCE



VENCO VENTURO INDUSTRIES LLC  
 CINCINNATI, OHIO

TITLE  
**REPLACEMENT PARTS DWG**  
 ET8 (14') & ET12 (15') SERIES

DATE  
**03-18-19B**  
 SUPERSEDES  
 03-08-19A

SECTION  
**C400**  
**28063**

# REPLACEMENT PARTS LIST; ET8 (14') & ET12 (15') SERIES - MECHANISM

ITEM	NON - PROPORTIONAL			PROPORTIONAL		PART NO.	DESCRIPTION
	ET8K QTY	ET8KX QTY	ET12KX QTY	ET8KX QTY	E12KX QTY		
1	1	1	1	1	1	16780-2P8	SLIP RING; 2-POLE, SWIVEL ASSY
2*	1	1	1	1	1	21735	SLEW DRIVE; SQUARE BASE
						21735-1	SLEW DRIVE; RECTANGULAR BASE
3	1	1	1	1	1	21185	ROTATION GEAR GUARD
4	1	1	1	1	1	22482	FEMALE INSERT; 16 + 1 POLE
5	1	1	1	1	1	22481	SOCKET CASE W/ HOOD
6	1	1	1	1	1	MB21621	ELECTRICAL ENCLOSURE W/ INSULATOR
7	1	1	1	1	1	21515	ASSY; ELECTRICAL COMPONENT PANEL
8	1	1	1	1	1	21540	PIVOT PIN; PRIMARY BOOM, MAIN
9	1	1	1	1	1	28113	COVER PLATE; RIGHT SIDE
10	-	1	1	1	1	28110	ADAPTER PLATE; HYD. CONTROL VALVE (ET8/12KX)
	1	-	-	-	-	28110-1	ADAPTER PLATE; HYD. CONTROL VALVE (ET8K ONLY)
11	1	1	1	1	1	28112	COVER PLATE; REAR
12	-	1	1	-	-	21614	ASSY; VALVE BLOCK, 3-SPOOL, NON-PROP (ET8/12KX ONLY)
	1	-	-	-	-	21615	ASSY; VALVE BLOCK, 2-SPOOL, NON-PROP (ET8K ONLY)
	-	-	-	1	1	26479	ASSY; VALVE BLOCK, 3-SPOOL, PROPORTIONAL
13	1	1	1	1	1	21556	WINCH; DC1600
14	1	1	1	1	1	28114	COVER PLATE; LEFT SIDE
15	1	1	1	1	1	16143-3	MOTOR COVER; 2 HOLES
16	1	1	1	1	1	20873	HYDRAULIC POWER UNIT; 2600 PSI
17	1	1	1	1	1	28122	WELDED ASSY; UNIVERSAL UPPER HSNG
18	-	-	1	-	1	23059	ASSY; ELEV. CYL., COMPOSITE BRNGS (ET12 SERIES)
	1	1	-	1	-	21788	ASSY; ELEV. CYL., COMPOSITE BRNGS (ET8 SERIES)
19	1	1	1	1	1	21547	PIN; ELEVATION CYL., OUTBOARD
20	1	1	1	1	1	23703	WELDMENT; ELEVATION CYL. PIN, INBOARD
21	2	2	2	2	2	14883	GROMMET; 3/8" ID, 5/8" OD, 3/16" GROOVE
22	1	1	1	1	1	21545	BRACKET; BOOM SHUT-OFF SWITCH
23	1	1	1	1	1	19918	SWITCH; TOP POSITION
24	1	1	1	1	1	19917	BRACKET; TOP POSITION SWITCH
25	2	2	2	2	2	21612	ASSY; HOSE CLAMP
26	1	1	1	1	1	23700	BOOM FINAL ASSY; ET12KXP 9.5' - 16'
27	1	1	1	1	1	20670	ASSY; SWIVEL LOAD BLOCK, 3500 LBS.

\* EITHER 21735 OR 2175-1 DEPENDING ON CONFIGURATION  
 ITEMS 26 & 27 NOT SHOWN ON DRAWING

REFERENCE DWG #28063 FOR REPLACEMENT PARTS DWG



TITLE	DATE	SECTION
RPLCMNT PARTS LIST - MECH	08-03-23G	C400
ET8 (14') & ET12 (15') SERIES	SUPERSEDES 03-06-23F	28064

# REPLACEMENT FASTENERS DWG; ET8 (14') & ET12 (15') SERIES, MECHANISM

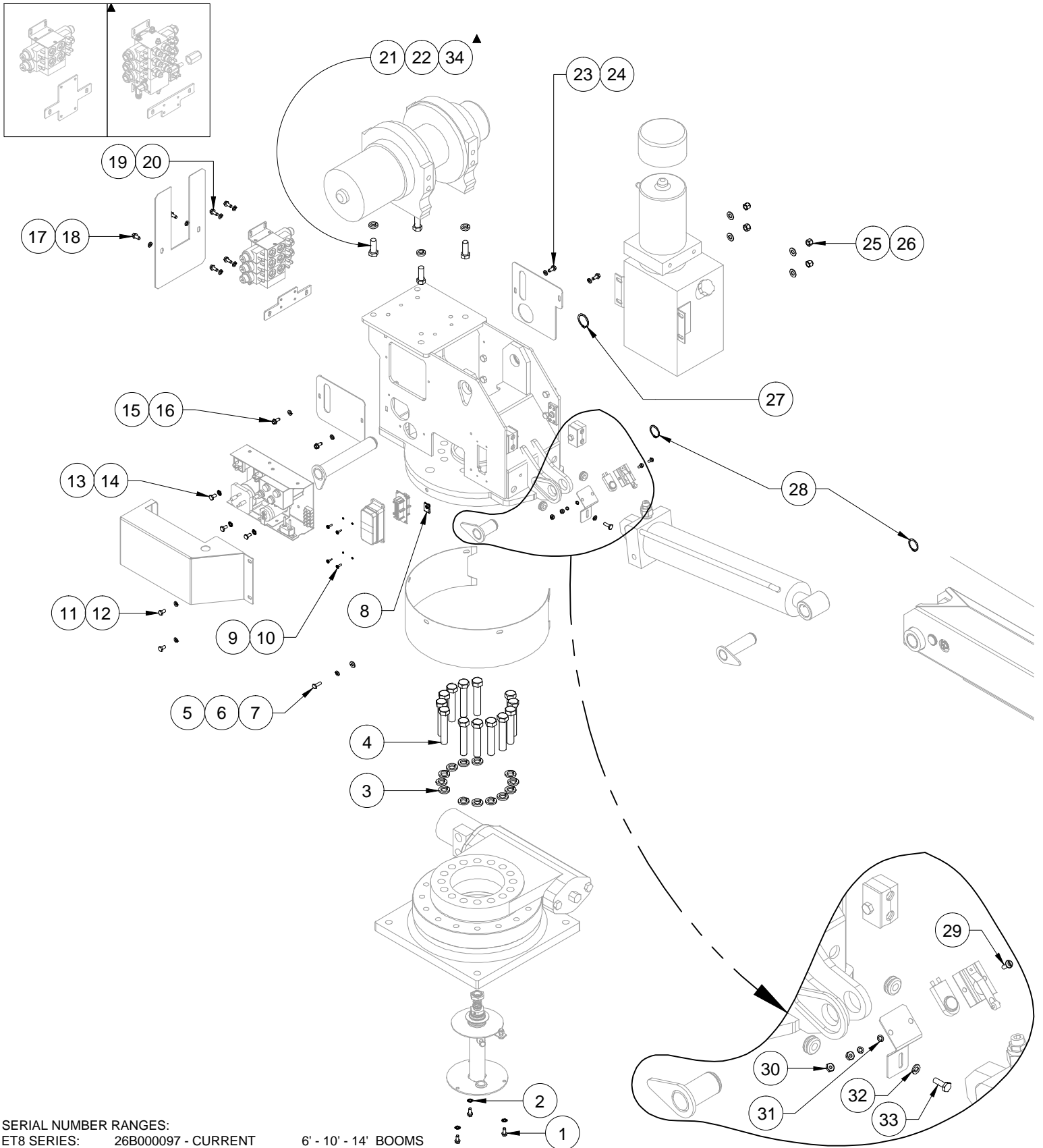

SERIAL NUMBER RANGES:

ET8 SERIES: 26B000097 - CURRENT

6' - 10' - 14' BOOMS

ET12 SERIES: 25B000156 - CURRENT

7' - 11' - 15' BOOMS

REFERENCE DWG #28067 FOR REPLACEMENT PARTS LIST



VENCO VENTURO INDUSTRIES LLC  
CINCINNATI, OHIO

TITLE	DATE	SECTION
RPLCMNT FASTENERS DWG	09-27-22B	C400
ET8 (14') & ET12 (15') SERIES	SUPERSEDES 03-08-19A	28066

# REPLACEMENT FASTENER LIST; ET8 (14') & ET12 (15') SERIES, MECHANISM

ITEM #	PART #	DESCRIPTION	QTY	INSTALLATION / LOCATION
1	!HHCS02520063S	HEX HEAD CAP SCREW; 1/4-20 X 5/8 S/S	3	CANDLESTICK TO CRANE BASE
2	!LWSH-025-STAR-SS	LOCK WASHER; 1/4", EXTERNAL STAR, S/S	3	CANDLESTICK TO CRANE BASE
3	!LWSH-063	LOCK WASHER; 5/8", GR. 5, ZINC	13	HOUSING TO SLEW RING
4	!HHCS06311350	HEX HEAD CAP SCREW; 5/8-11 x 3-1/2, GR. 5, ZINC	13	HSNG TO SLEW RING (TORQUE 160 LBS.)
5	!HHCS02520075S	HEX HEAD CAP SCREW; 1/4-20 X 3/4, S/S	5	ROTATION GEAR GUARD TO HOUSING
6	!LWSH-025S	LOCK WASHER; 1/4", S/S	5	ROTATION GEAR GUARD TO HOUSING
7	!FWSH-025S	FLAT WASHER; 1/4", S/S	5	ROTATION GEAR GUARD TO HOUSING
8	!UNUT-02520-LKG	U-NUT; 1/4-20, LOCKING	5	LOWER GUARD MOUNTING RING (HSNG)
9	!SHPMS#0832050S	SLOT-HEAD PAN MACHINE SCREW; #8-32 X 1/2, S/S	4	SOCKET CASE W/ HOOD TO HOUSING
10	!LWSH-#08S	LOCK WASHER; #08, S/S	4	SOCKET CASE W/ HOOD TO HOUSING
11	!HHCS02520063S	HEX HEAD CAP SCREW; 1/4-20 X 5/8, S/S	2	ELECTRIC PANEL COVER TO HOUSING
12	!LWSH-025S	LOCK WASHER; 1/4, S/S	2	ELECTRIC PANEL COVER TO HOUSING
13	!HHCS02520063	HEX HEAD CAP SCREW; 1/4-20 X 5/8, S/S	3	ELECTRICAL COMPONENT PANEL TO HSNG
14	!LWSH-025-STAR	LOCK WASHER; 1/4, EXTERNAL STAR	3	ELECTRICAL COMPONENT PANEL TO HSNG
15	!HHCS02520050S	HEX HEAD CAP SCREW; 1/4-20 X 1/2, S/S	2	RIGHT SIDE COVER PLATE TO HOUSING
16	!LWSH-025-S	LOCK WASHER; 1/4, S/S	2	RIGHT SIDE COVER PLATE TO HOUSING
17	!HHCS02520063S	HEX HEAD CAP SCREW; 1/4-20 X 5/8, S/S	2	REAR COVER & ADAPTER PLATE TO HOUSING
18	!LWSH-025-S	LOCK WASHER; 1/4, S/S	2	REAR COVER & ADAPER PLATE TO HOUSING
19	!HHCS02520063S	HEX HEAD CAP SCREW; 1/4-20 X 5/8, S/S	4	VALVE BLOCK TO ADAPTER PLATE & HSNG
20	!LWSH-025-S	LOCK WASHER; 1/4, S/S	4	VALVE BLOCK TO ADAPTER PLATE & HSNG
21°	25922	SHCS; M12-175 X 35MM, GR. 12.9	4	WARN WINCH TO HOUSING
21*	25920	SHCS; M10-150 X 50MM, GR. 12.9	6	COMEUP WINCH TO HOUSING
22°	!LWSH-M12-8.8	LOCK WASHER; M12, GRADE 8.8	4	WARN WINCH TO HOUSING
22*	!LWSH-M10-18.1MM-OD	LOCK WASHER; M10, 18.1MM OD	6	COMEUP WINCH TO HOUSING
23	!HHCS02520063S	HEX HEAD CA SCREW; 1/4-20 X 5/8, S/S	2	LEFT SIDE COVER PLATE TO HOUSING
24	!LWSH-025-S	LOCK WASHER; 1/4, S/S	2	LEFT SIDE COVER PLATE TO HOUSING
25	!LNUT-03816	LOCK NUT; 3/8-16, NYLON INSERT	4	HYDRAULIC POWER UNIT TO HOUSING
26	!FWSH-038SAE	FLAT WASHER; 3/8 SAE, ZINC PLATED	4	HYDRAULIC POWER UNIT TO HOUSING
27	!SRNG-125	SNAP RING; 1-1/4, PLATED	1	MAIN BOOM PIVOT PIN
28	!SRNG-113	SNAP RING; 1-1/8, PLATED	2	ELEVATION CYLINDER PIVOT PINS
29	!PHPMS#1024050S	PHILLIPS HEAD PAN MACH. SCREW; 10-24 X 1/2, S/S	2	TOP POS. BRCKT TO BOOM SHUT-OFF BRCKT
30	!LWSH-#10S	LOCK WASHER; #10, S/S	2	TOP POS. BRCKT TO BOOM SHUT-OFF BRCKT
31	!HNUT-#1024S	HEX NUT; #10-24, S/S	2	TOP POS. BRCKT TO BOOM SHUT-OFF BRCKT
32	!LWSH-025-S	LOCK WASHER; 1/4, S/S	1	BOOM SHUT-OFF SWITCH BRACKET TO HSNG
33	!HHCS02520075S	HEX HEAD CAP SCREW; 1/4-20 X 3/4, S/S	1	BOOM SHUT-OFF SWITCH BRACKET TO HSNG
34°	!FWSH-M12	FLAT WASHER; M12	4	WARN WINCH TO HOUSING
34*	!FWSH-M10-18MM-OD	FLAT WASHER; M10, 18MM OD	6	COMEUP WINCH TO HOUSING

° = WARN DC2500 WINCH MOUNTING

\* = COMEUP GTD-2800 WINCH MOUNTING

REFERENCE DWG #28066 FOR REPLACEMENT FASTENER DRAWING



VENCO VENTURO INDUSTRIES LLC  
CINCINNATI, OHIO

TITLE

RPLCMNT FASTENER LIST

DATE

09-27-22B

SECTION

C400

ET8 (14' & ET12 (15') SERIES

SUPERSEDES

03-08-19A

28067

# 28008-1; ET12KX(P)

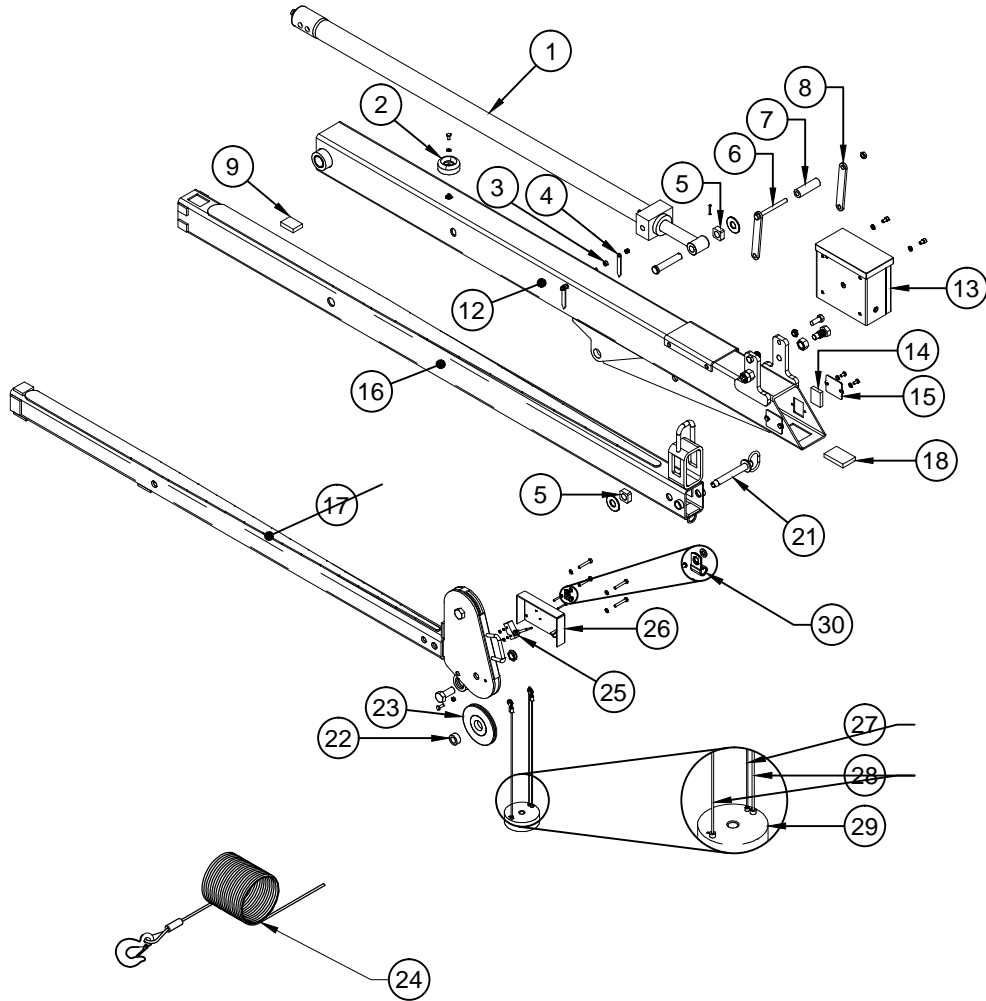

REFERENCE #28123 FOR REPLACEMENT PARTS LIST

# 28008; ET12K

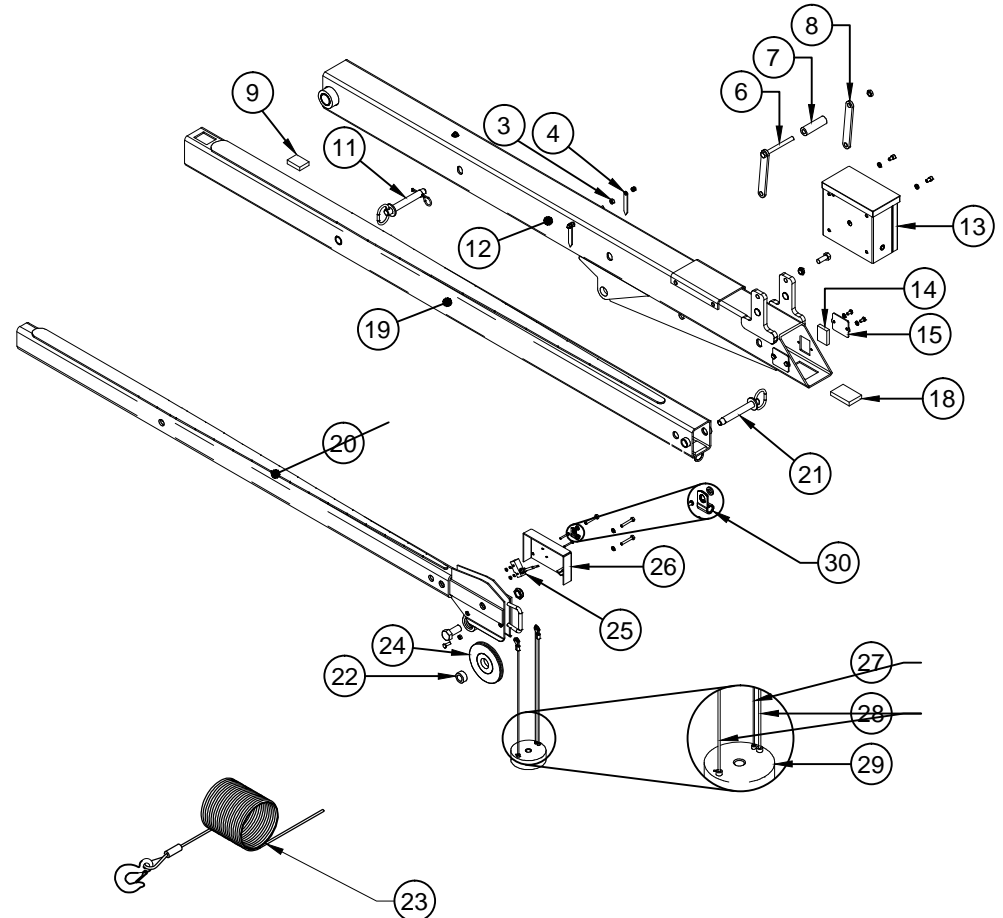

ET12 SERIES SERIAL NUMBER RANGES: 25B000156 - CURRENT



VENCO VENTURO INDUSTRIES LLC  
CINCINNATI, OHIO

TITLE

REPLACEMENT PARTS DWG; 28008-1 & 28008

ET12 GEN. 'C' SERIES, 7'-11'-15' BOOMS

DATE

11-20-19A

SUPERSEDES

03-14-19

SECTION

C400

28123

REPLACEMENT PARTS LIST; 28008-1, ET12KX(P)			
ITEM #	QTY	PART #	DESCRIPTION
1	1	21754	EXTENSION CYLINDER
2	1	20285	BUMPER; BOOM
3	2	22490	SPACER; BOOM ARROW
4	2	13459-1	ARROW; 3.19" LONG
5	2	21734	BEARING; UHMW, EXTENSION PIN
6	1	27089	WELDED ASSY; WIRE ROPE GUIDE
7	1	27088	ROLLER; UHMW, WIRE ROPE GUIDE
8	1	21936	FLAT MOUNT; WIRE ROPE GUIDE
9	1	21538	BEARING; UHMW, BOOM, 2 X 1.5 X 0.5
10	-	-	-
11	-	-	-
12	1	28010-1	WELDED ASSY; PRIMARY BOOM
13	1	22683	ASSY; CORD REEL, LEFT
14	2	21209	BEARING; UHMW, BOOM, 2 X 1.5 X 0.44
15	2	21528	BEARING CAP
16	1	28016	WELDED ASSY; SECONDARY BOOM
17	1	21534	WELDED ASSY; TERTIARY BOOM
18	1	21208	BEARING; UHMW, BOOM, 3 X 2 X 0.5
19	-	-	-
20	-	-	-
21	1	23042-B-14-14	ASSY; PIN / LANYARD
22	2	20536	SPACER; SHEAVE
23	2	21630	SHEAVE W/ BUSHING
24	1	21639	WIRE ROPE; 1/4 X 65 FT W/ EYEHOOK
25	1	19376	SWITCH; ANTI-2-BLOCK
26	1	21291	HOUSING; ANTI-2-BLOCK
27	1	20929	CABLE HANGER; ANTI-TWO BLOCK
28	2	20951-1	CABLE HANGER; 16 1/2" LG
29	1	20950	WEIGHT; ANTI-TWO BLOCK
30	1	19269	CLAMP; 1/4"

REFERENCE #28123 FOR REPLACEMENT PARTS DRAWING

REPLACEMENT PARTS LIST; 28008, ET12K			
ITEM #	QTY	PART #	DESCRIPTION
1	-	-	-
2	-	-	-
3	2	22490	SPACER; BOOM ARROW
4	2	13459-1	ARROW; 3.19" LONG
5	-	-	-
6	1	27089	WELDED ASSY; WIRE ROPE GUIDE
7	1	27088	ROLLER; UHMW, WIRE ROPE GUIDE
8	1	21936	FLAT MOUNT; WIRE ROPE GUIDE
9	1	21538	BEARING; UHMW, BOOM, 2 X 1.5 X 0.5
10	-	-	-
11	1	23042-B-34-34	ASSY; PIN / LANYARD
12	1	28010	WELDED ASSY; PRIMARY BOOM
13	1	22683	ASSY; CORD REEL, LEFT
14	2	21209	BEARING; UHMW, BOOM, 2 X 1.5 X 0.44
15	2	21528	BEARING CAP
16	-	-	-
17	-	-	-
18	1	21208	BEARING; UHMW, BOOM, 3 X 2 X 0.5
19	1	21550	WELDED ASSY; SECONDARY BOOM
20	1	21551	WELDE ASSY; TERTIARY BOOM
21	1	23042-B-14-14	ASSY; PIN / LANYARD
22	1	20536	SPACER; SHEAVE
23	1	21639	WIRE ROPE; 1/4 X 65 FT W/ EYEHOOK
24	1	20537	SHEAVE W/ BUSHING
25	1	19376	SWITCH; ANTI-2-BLOCK
26	1	21291	HOUSING; ANTI-2-BLOCK
27	1	20929	CABLE HANGER; ANTI-TWO BLOCK
28	2	20951-1	CABLE HANGER; 16 1/2" LG
29	1	20950	WEIGHT; ANTI-TWO BLOCK
30	1	19269	CLAMP; 1/4"

ET12 SERIES SERIAL NUMBER RANGES: 25B000156 - CURRENT



VENCO VENTURO INDUSTRIES LLC  
CINCINNATI, OHIO

TITLE

REPLACEMENT PARTS LIST - 28008-1 & 28008

ET12 GEN. 'C' SERIES, 7' - 11' - 15' BOOMS

DATE

11-20-19A

SUPERSEDES

03-14-19

SECTION

C400

28124

28008-1; ET12KX(P)

28008; ET12K

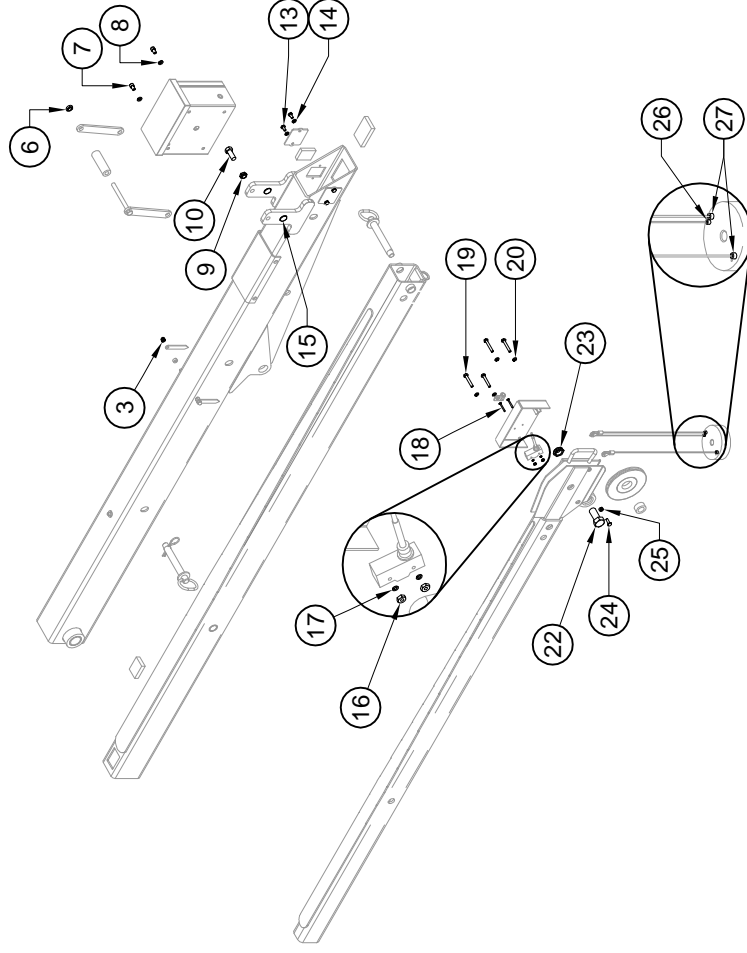
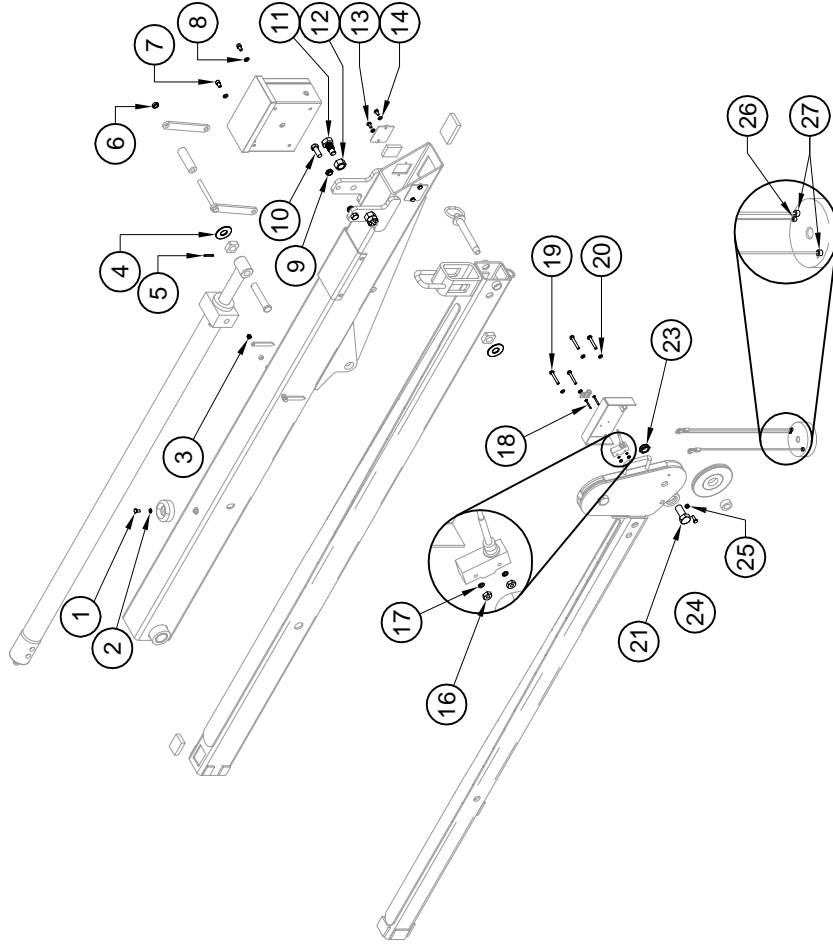

REFERENCE #28126 FOR REPLACEMENT PARTS LIST

ET12 SERIES SERIAL NUMBER RANGES: 25B000156 - CURRENT



VENCO VENTURO INDUSTRIES LLC  
CINCINNATI, OHIO

TITLE

RPLCMNT FASTENERS DWG; 28008-1 & 28008  
ET12 GEN. 'C' SERIES, 7'-11'-15' BOOMS

DATE

03-14-19

SECTION

C400

SUPERSEDES

28125



REPLACEMENT FASTENERS LIST; 28008-1, ET12KX(P)		
ITEM #	QTY	PART # DESCRIPTION
1	1	IHHCS02520063S HEX HEAD CAP SCREW; 1/4-20 X 5/8", S/S
2	1	!FWSH-025S FLAT WASHER; 1/4", S/S
3	2	!ANUT-02520S ACORN NUT; 1/4-20, S/S
4	2	!FWSH-075S FLAT WASHER; 3/4", S/S
5	1	!RPIN-016150 ROLL PIN; 5/32 X 1-1/2"
6	1	!JNUT-04414N JAM NUT; 7/16-14, NYLON
7	2	!SHCS03118050-SS SOCKET HEAD CAP SCREW; 5/16-18 X 1/2", S/S
8	2	!LWSH-031S LOCK WASHER; 5/16", S/S
9	2	!JNUT-05013N JAM NUT; 1/2-13, NYLON
10	2	!HHCS05013125 HEX HEAD CAP SCREW; 1/2-13 X 1-1/4", ZINC
11	2	17487 ECCENTRIC PIVOT BOLT; 3/4-16
12	2	!HNUT-07516S HEX NUT; 3/4-16, S/S
13	4	!HHCS02520050S HEX HEAD CAP SCREW; 1/4-20 X 1/2", S/S
14	4	!LWSH-025S LOCK WASHER; 1/4", S/S
15	-	-
16	2	!HNUT-#0632S HEX NUT; #06-32, S/S
17	2	!LWSH-#06S LOCK WASHER; #06, S/S
18	2	!PHMS#0632125 PHILIPS HEAD MACHINE SCREW; #06-32 X 1-1/4"
19	4	!HHCS02520175S HEX HEAD CAP SCREW; 1/4-20 X 1-3/4", S/S
20	4	!LWSH-025S LOCK WASHER; 1/4", S/S
21	2	17059-4 SHEAVE AXLE; HHCS07510169, SPCL SHLDR, S/S
22	-	-
23	2	!JNUT-07510N JAM NUT; 3/4-10, NYLON
24	1	!HHCS02520075S HEX HEAD CAP SCREW; 1/4-20 X 3/4", S/S
25	1	!HNUT-025S HEX NUT; 1/4", S/S
26	2	19302 SET COLLAR; 3/32" DIA.
27	2	20952 SET COLLAR; 5/32" DIA.

REPLACEMENT FASTENERS LIST; 28008, ET12K		
ITEM #	QTY	PART # DESCRIPTION
1	-	-
2	-	-
3	2	!ANUT-02520S ACORN NUT; 1/4-20, S/S
4	-	-
5	-	-
6	1	!JNUT-04414N JAM NUT; 7/16-14, NYLON
7	2	!SHCS03118050-SS SOCKET HEAD CAP SCREW; 5/16-18 X 1/2", S/S
8	2	!LWSH-031S LOCK WASHER; 5/16", S/S
9	2	!JNUT-05013N JAM NUT; 1/2-13, NYLON
10	2	!HHCS05013125 HEX HEAD CAP SCREW; 1/2-13 X 1-1/4", ZINC
11	-	-
12	-	-
13	4	!HHCS02520050S HEX HEAD CAP SCREW; 1/4-20 X 1/2", S/S
14	4	!LWSH-025S LOCK WASHER; 1/4", S/S
15	4	28019 PLUG; 11/16" HOLE
16	2	!HNUT-#0632S HEX NUT; #06-32, S/S
17	2	!LWSH-#06S LOCK WASHER; #06, S/S
18	2	!PHMS#0632125 PHILIPS HEAD MACHINE SCREW; #06-32 X 1-1/4"
19	4	!HHCS02520175S HEX HEAD CAP SCREW; 1/4-20 X 1-3/4", S/S
20	4	!LWSH-025S LOCK WASHER; 1/4", S/S
21	-	-
22	1	17059-6 SHEAVE AXLE; HHCS07510200,1" SPCL SHLDR, S/S
23	2	!JNUT-07510N JAM NUT; 3/4-10, NYLON
24	1	!HHCS02520075S HEX HEAD CAP SCREW; 1/4-20 X 3/4", S/S
25	1	!HNUT-025S HEX NUT; 1/4", S/S
26	2	19302 SET COLLAR; 3/32" DIA.
27	2	20952 SET COLLAR; 5/32" DIA.

REFERENCE #28125 FOR REPLACEMENT FASTENERS DRAWING

ET12 SERIES SERIAL NUMBER RANGES: 25B000156 - CURRENT



VENCO VENTURO INDUSTRIES LLC  
CINCINNATI, OHIO

TITLE

RPLCMNT FASTENERS LIST - 28008-1 & 28008

DATE

03-14-19

SECTION

C400

SUPERSEDES

ET12 GEN. 'C' SERIES, 7' - 11' - 15' BOOMS

-

28126

# BOOM ROUND CORD REEL 28190-2

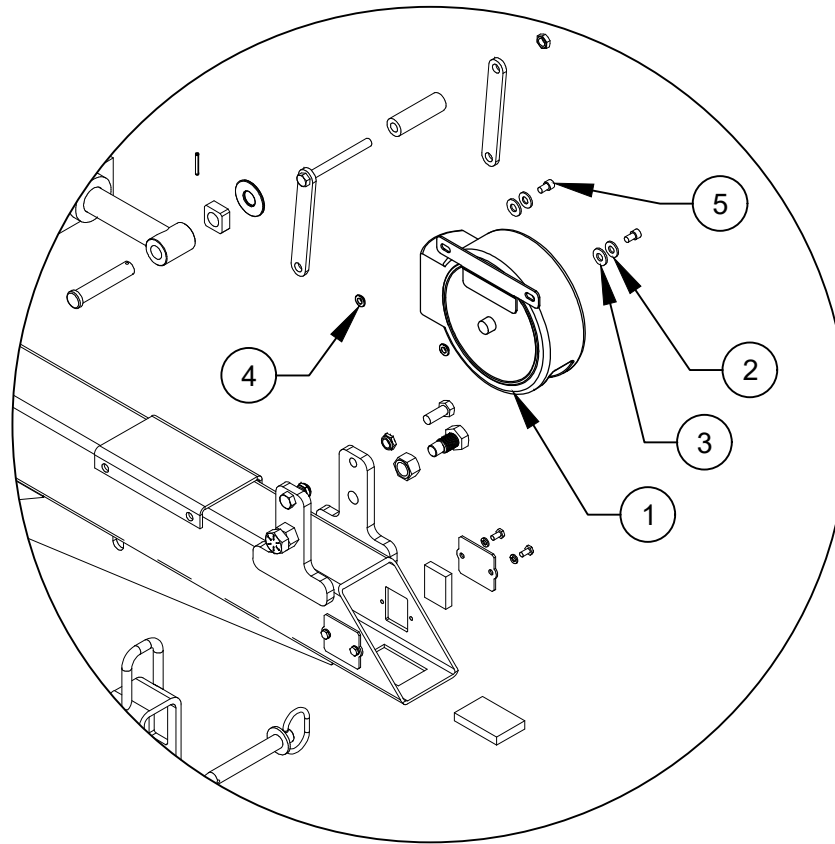

ITEM NO.	QTY.	PART NUMBER	DESCRIPTION
1	1	28190-2	CORD REEL
2	2	IFWSH-031	WASHER FLAT; 5/16"X.75 O.D., 304 S/S
3	2	01016	FIBER WASHER
4	2	28198	INSULATING SLEEVE WASHER; 5/16"
5	2	ISHCS03118063S	SHCS; 5/16"-18X5/8"LG.S/S



VENCO VENTURO INDUSTRIES LLC  
CINCINNATI, OHIO

TITLE  
BOOM ROUND CORD REEL 28190-2  
ET12KX -15', ET8KX(P)-14'

DATE  
02-13-24  
SUPERSEDES  
-

SECTION  
C400  
24102

# 21515 ELECTRICAL COMPONENT ASSEMBLY

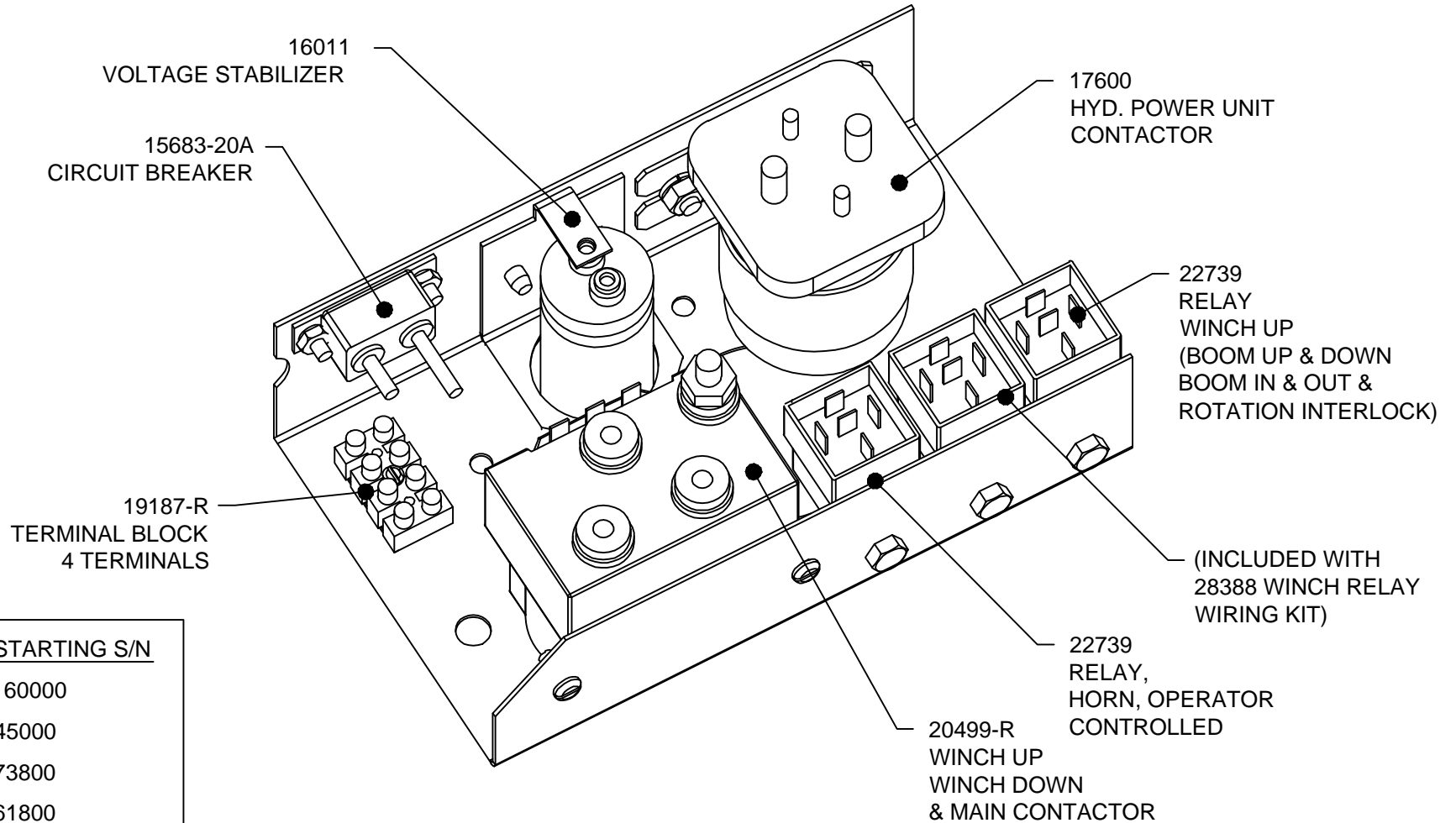

MODEL	STARTING S/N
ET6K	160000
ET8K	45000
ET8KX	73800
ET12K	61800
ET12KX	69800
ET12KXP	25C000001



VENCO VENTURO INDUSTRIES LLC  
CINCINNATI, OHIO

TITLE

ELECTRICAL COMPONENT ASSEMBLY

ET6K, ET8/12K(X), ET12KXP

DATE

03-02-23G

SUPERSEDES

07-31-18F

SECTION

C400

21600

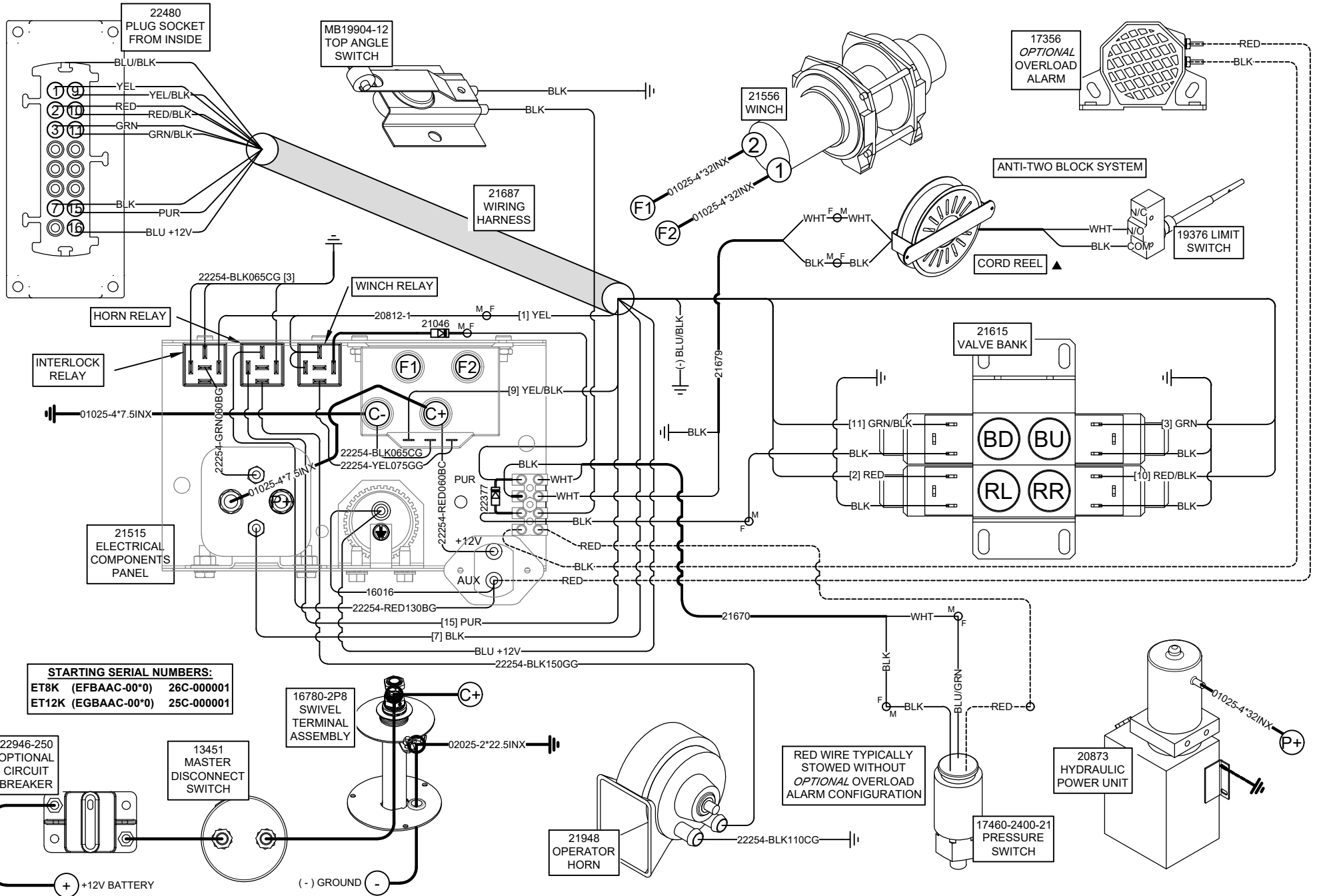

**STARTING SERIAL NUMBERS:**  
 ET8K (EFBAAC-00\*0) 26C-000001  
 ET12K (EGBAAC-00\*0) 25C-000001

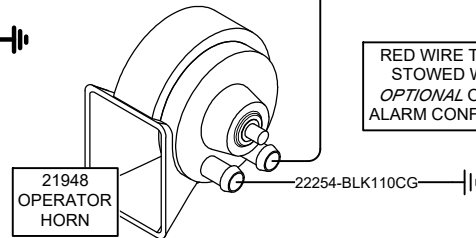
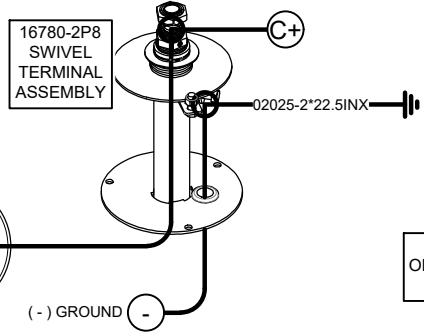
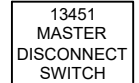
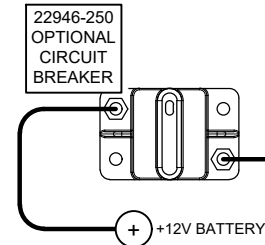

RED WIRE TYPICALLY STOWED WITHOUT  
 OPTIONAL OVERLOAD ALARM CONFIGURATION

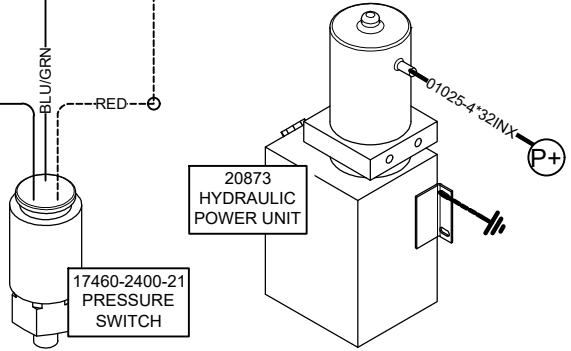

VENCO VENTURO INDUSTRIES LLC  
 CINCINNATI, OHIO

TITLE  
**WIRING DIAGRAM**

ET8/12K

DATE  
 03-29-24D

SUPERSEDES  
 04-07-21C

SECTION  
 C400

26521

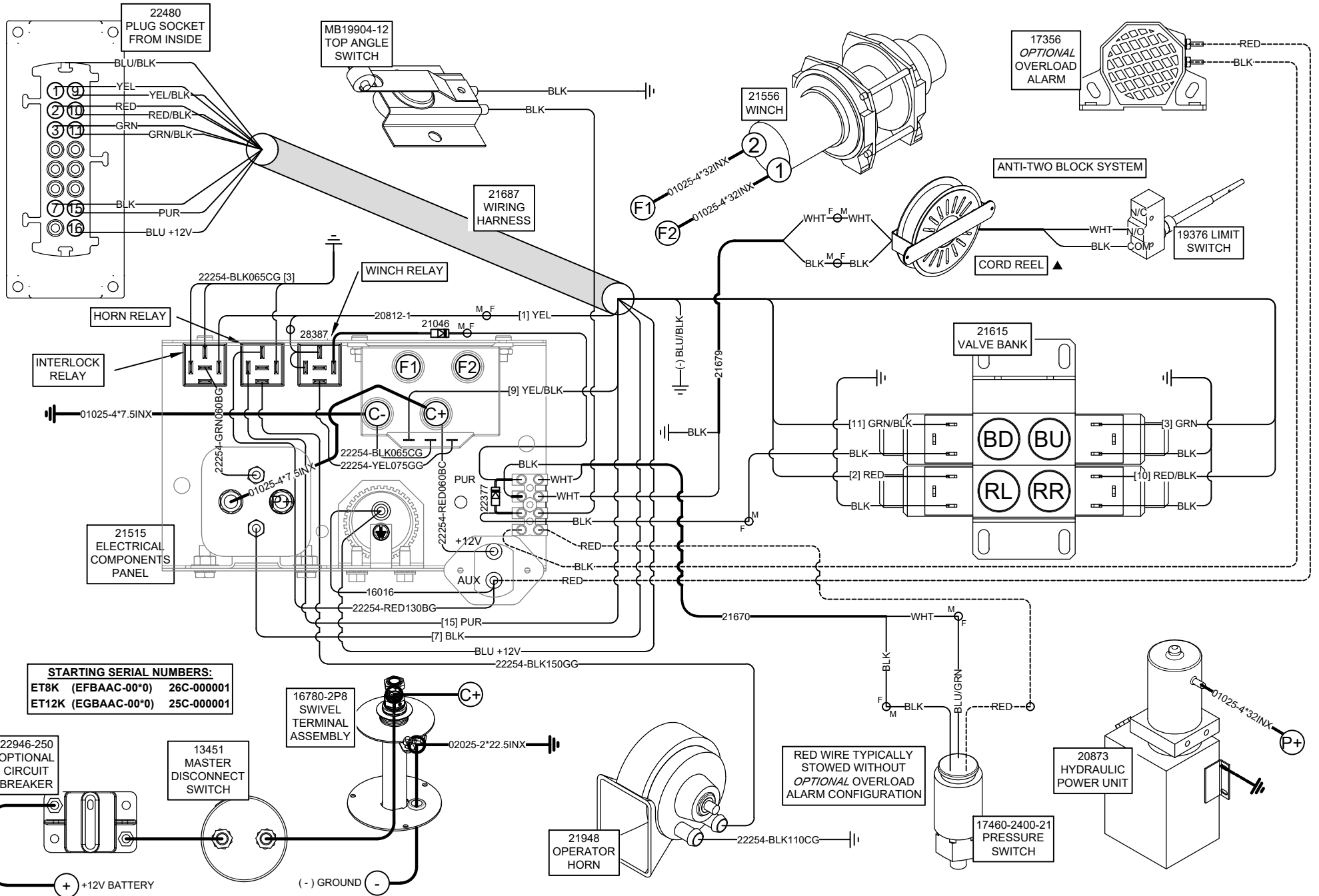

VENCO VENTURO INDUSTRIES LLC  
 CINCINNATI, OHIO

TITLE  
**WIRING DIAGRAM**

ET8/12K W/ WINCH RELAY, COMEUP/WARN

DATE  
**03-29-24A**

SECTION  
**C400**

SUPERSEDES  
**04-05-22**

**26536**

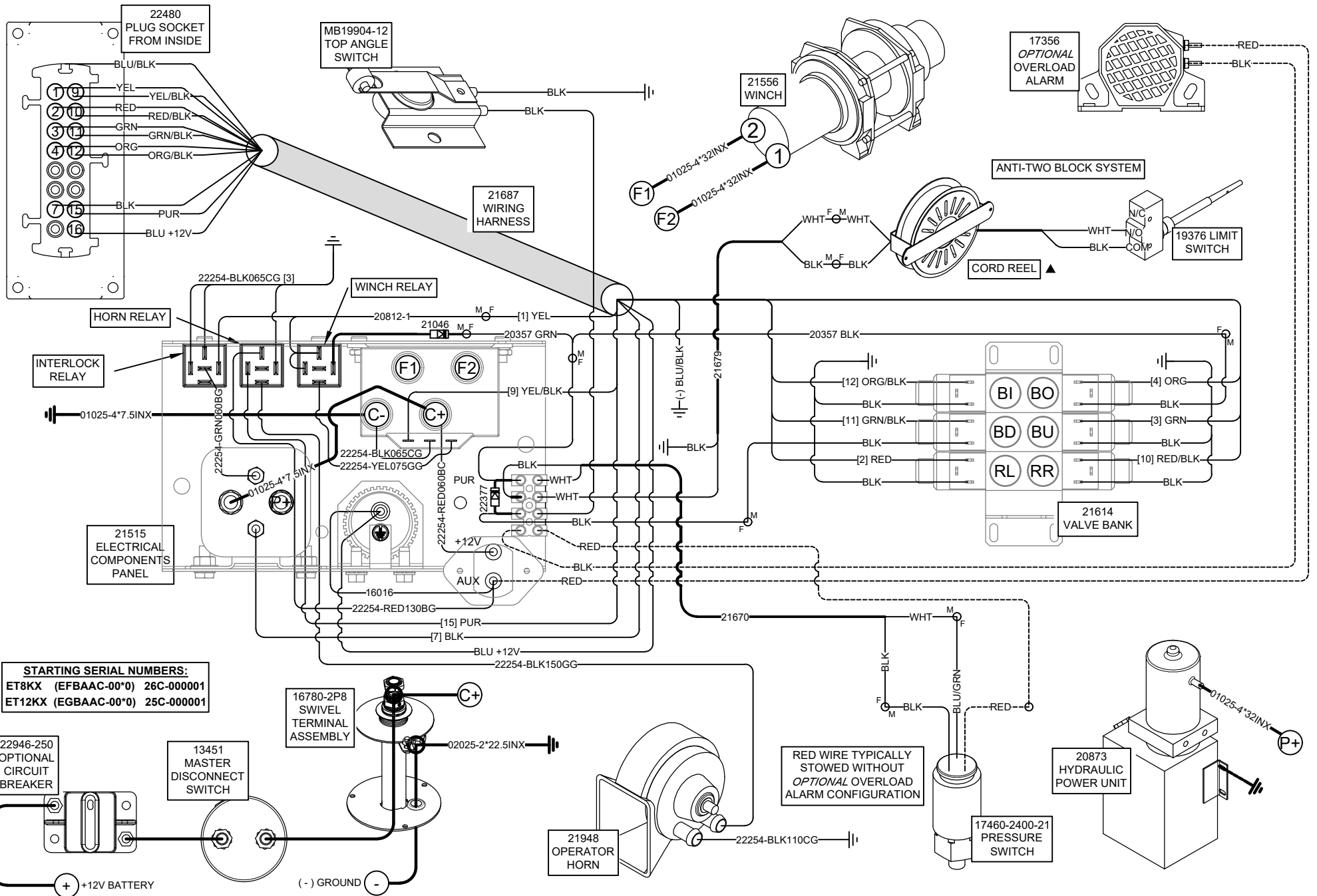

VENCO VENTURO INDUSTRIES LLC  
 CINCINNATI, OHIO

TITLE  
**WIRING DIAGRAM**

ET8/12KX

DATE  
 03-29-24D SECTION  
 C400

SUPERSEDES  
 04-07-21C

26522

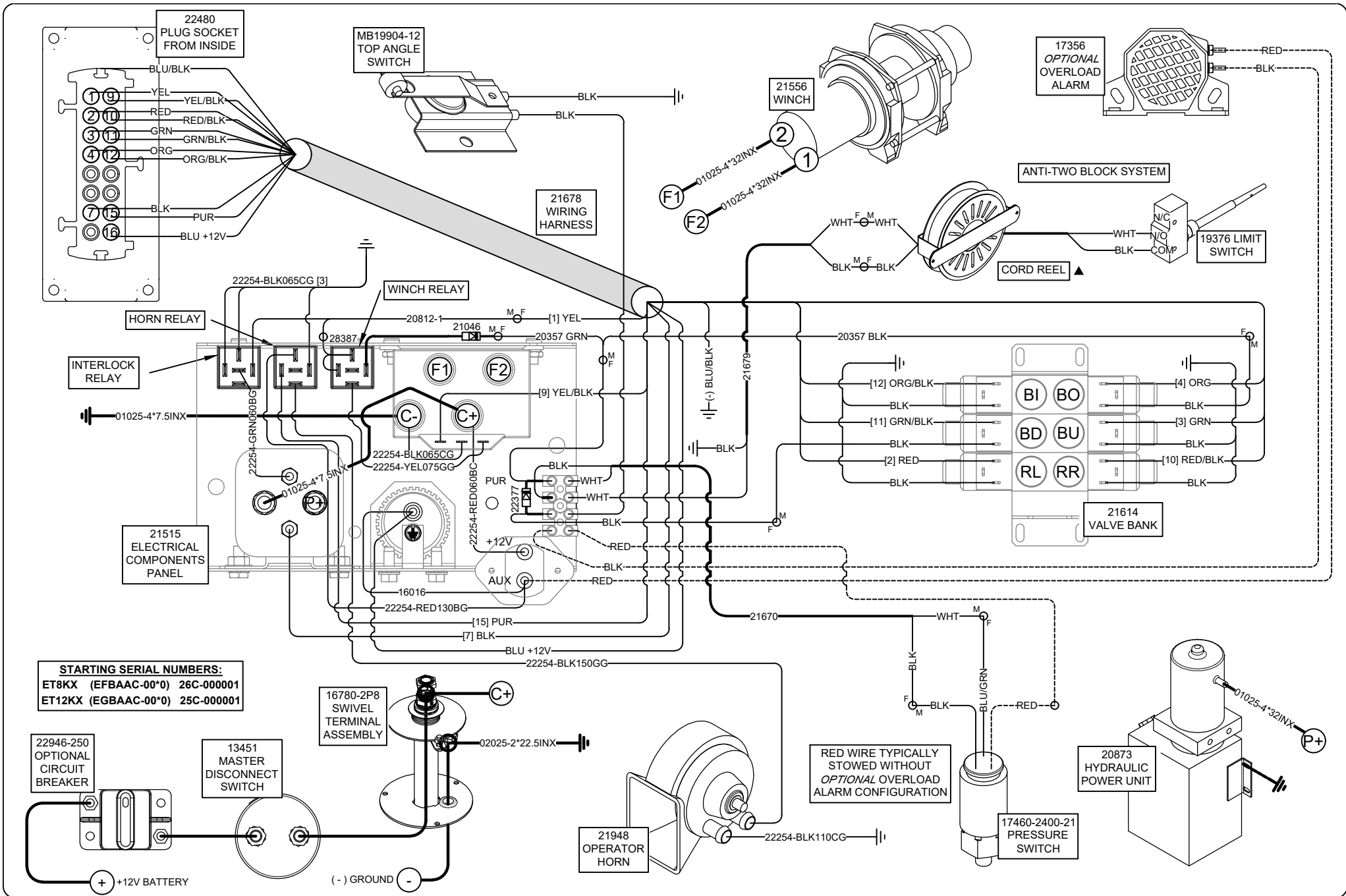

VENCO VENTURO INDUSTRIES LLC  
CINCINNATI, OHIO

TITLE  
**WIRING DIAGRAM**

ET8/12KX W/ WINCH RELAY, COMEUP/WARN

DATE  
03-29-24B

SECTION  
C400

SUPERSEDES  
01-16-24A

26537

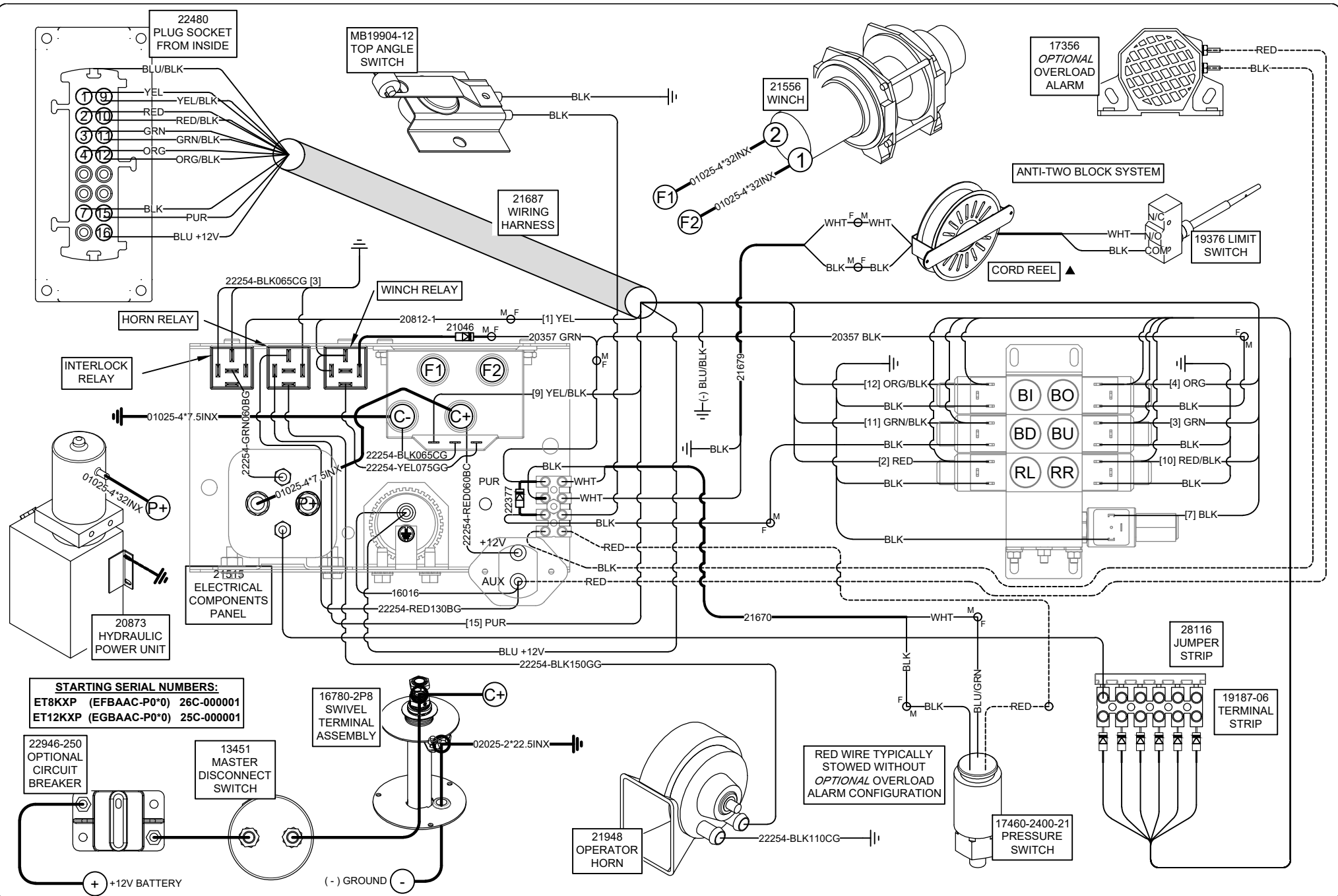

**STARTING SERIAL NUMBERS:**  
 ET8KXP (EFBAAC-P0\*0) 26C-000001  
 ET12KXP (EGBAAC-P0\*0) 25C-000001

RED WIRE TYPICALLY STOWED WITHOUT OPTIONAL OVERLOAD ALARM CONFIGURATION



VENCO VENTURO INDUSTRIES LLC  
 CINCINNATI, OHIO

TITLE <b>WIRING DIAGRAM</b>		DATE <b>03-29-24D</b>	SECTION <b>C400</b>
ET8KXP, ET12KXP-15'		SUPERSEDES <b>04-07-21C</b>	<b>26523</b>



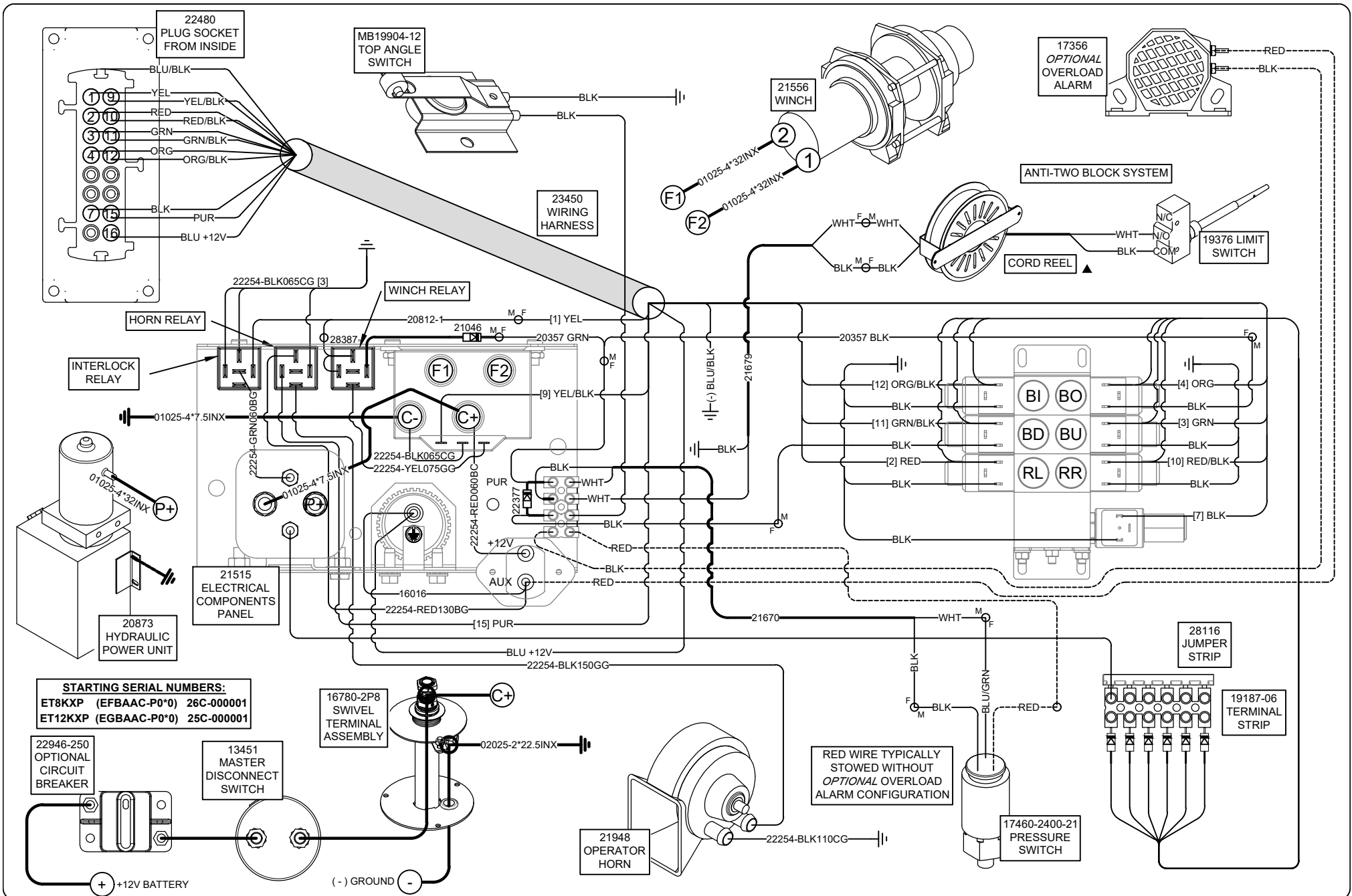

VENCO VENTURO INDUSTRIES LLC  
 CINCINNATI, OHIO

TITLE	DATE	SECTION
<b>WIRING DIAGRAM</b>	<b>03-29-24B</b>	<b>C400</b>
ET8KXP, ET12KXP-15' W/ WINCH RELAY	SUPERSEDES	
	<b>01-16-24A</b>	<b>26538</b>

# REPLACEMENT PARTS; HYDRAULIC COMPONENTS, ET8 (6-10-14) & ET12 (7-11-15) GEN 'C' SERIES

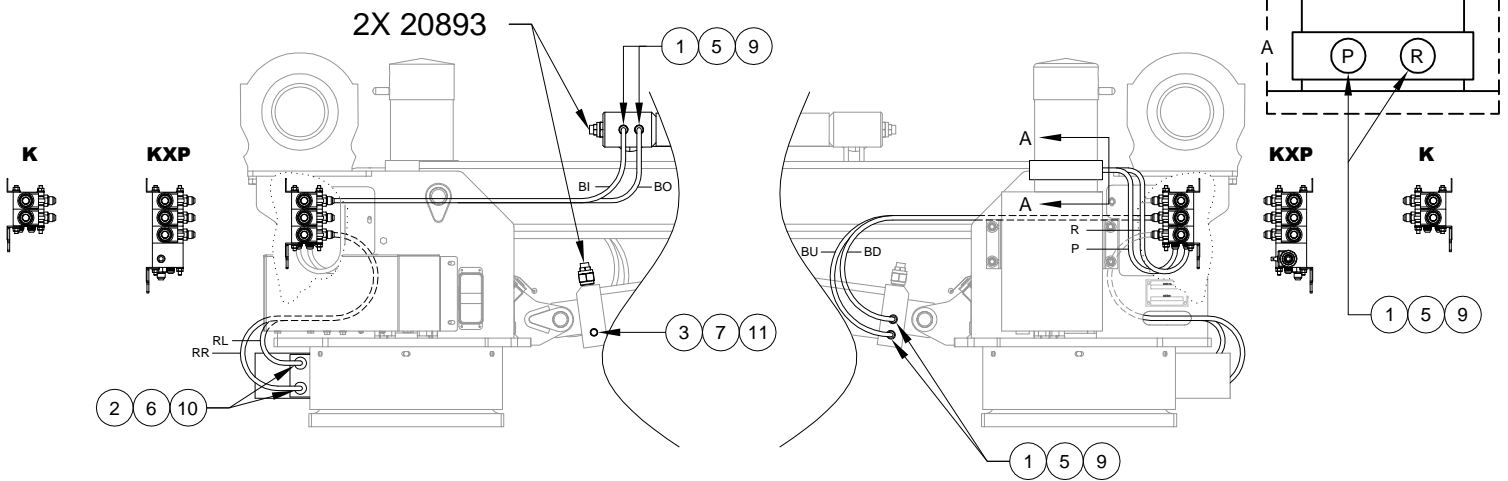

23737 - ET8K GENERATION 'C', NON-PROPORTIONAL, 6' - 10' - 14'

ITEM	PART #	QTY	DESCRIPTION
1	FF6400-0606	8	FITTING; ADAPTER, STRAIGHT, 6OFS-6MO
2	FF6400-0610	2	FITTING; ADAPTER, STRAIGHT, 6OFS-10MO
3	H6805-0404	1	FITTING; ADAPTER, 90° ELBOW, 4MO-4FP
4	FF6802-0606	2	FITTING; ADAPTER, 45° SWIVEL, 6MOFS-6MORB

23734 - ET8KX (6'-10'-14') & ET12KX (7'-11'-15') GEN. 'C', NON-PROPORTIONAL

ITEM	PART #	QTY	DESCRIPTION
5	FF6400-0606	10	FITTING; ADAPTER, STRAIGHT, 6OFS-6MO
6	FF6400-0610	2	FITTING; ADAPTER, STRAIGHT, 6OFS-10MO
7	H6805-0404	1	FITTING; ADAPTER, 90° ELBOW, 4MO-4FP
8	FF6802-0606	4	FITTING; ADAPTER, 45° SWIVEL, 6MOFS-6MORB

23735 - ET8KXP (6'-10'-14') & ET12KXP (7'-11'-15'), GEN. 'C', PROPORTIONAL

ITEM	PART #	QTY	DESCRIPTION
9	FF6400-0606	10	FITTING; ADAPTER, STRAIGHT, 6OFS-6MO
10	FF6400-0610	2	FITTING; ADAPTER, STRAIGHT, 6OFS-10MO
11	H6805-0404	1	FITTING; ADAPTER, 90° ELBOW, 4MO-4FP
12	FF6802-0606	4	FITTING; ADAPTER, 45° SWIVEL, 6MOFS-6MORB

**21615 (K) or 21614 (KX) NON-PROPORTIONAL VALVE BLOCK**

**26479 (KXP) PROPORTIONAL VALVE BLOCK**

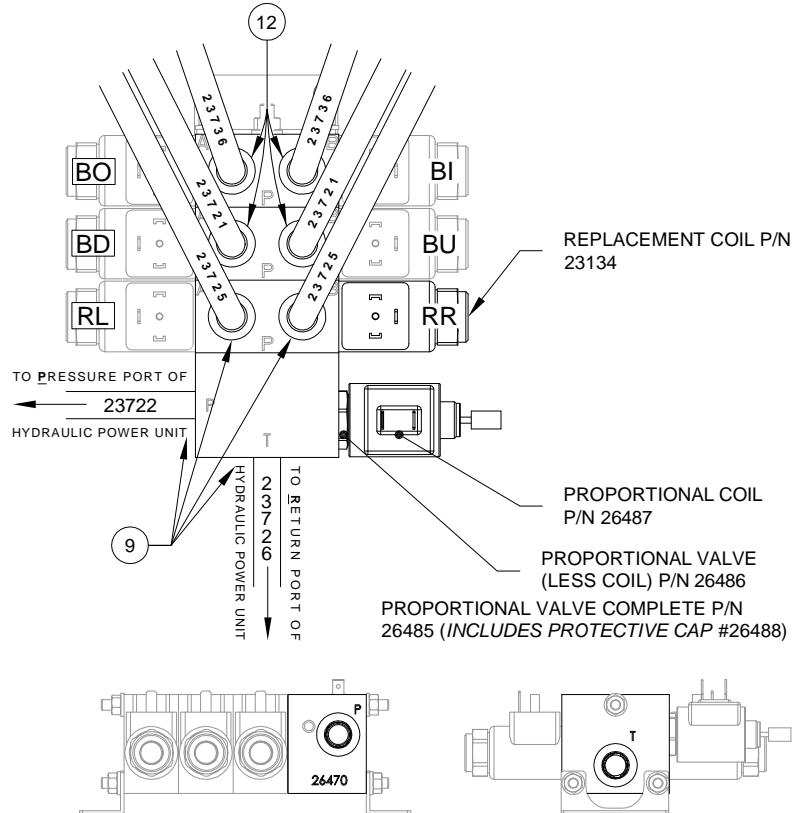
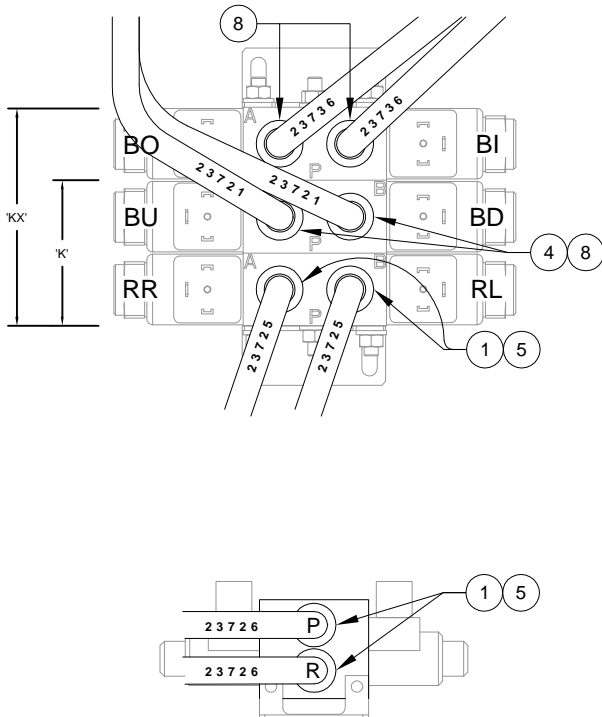

HOSE ROUTINGS ARE FOR REFERENCE ONLY

SCALE 1:13



VENCO VENTURO INDUSTRIES LLC  
CINCINNATI, OHIO

TITLE	DATE	SECTION
REPLACEMENT PARTS	03-08-19F	C400
ET8 (14') & ET12 (15') SERIES	SUPERSEDES 12-16-16E	28037

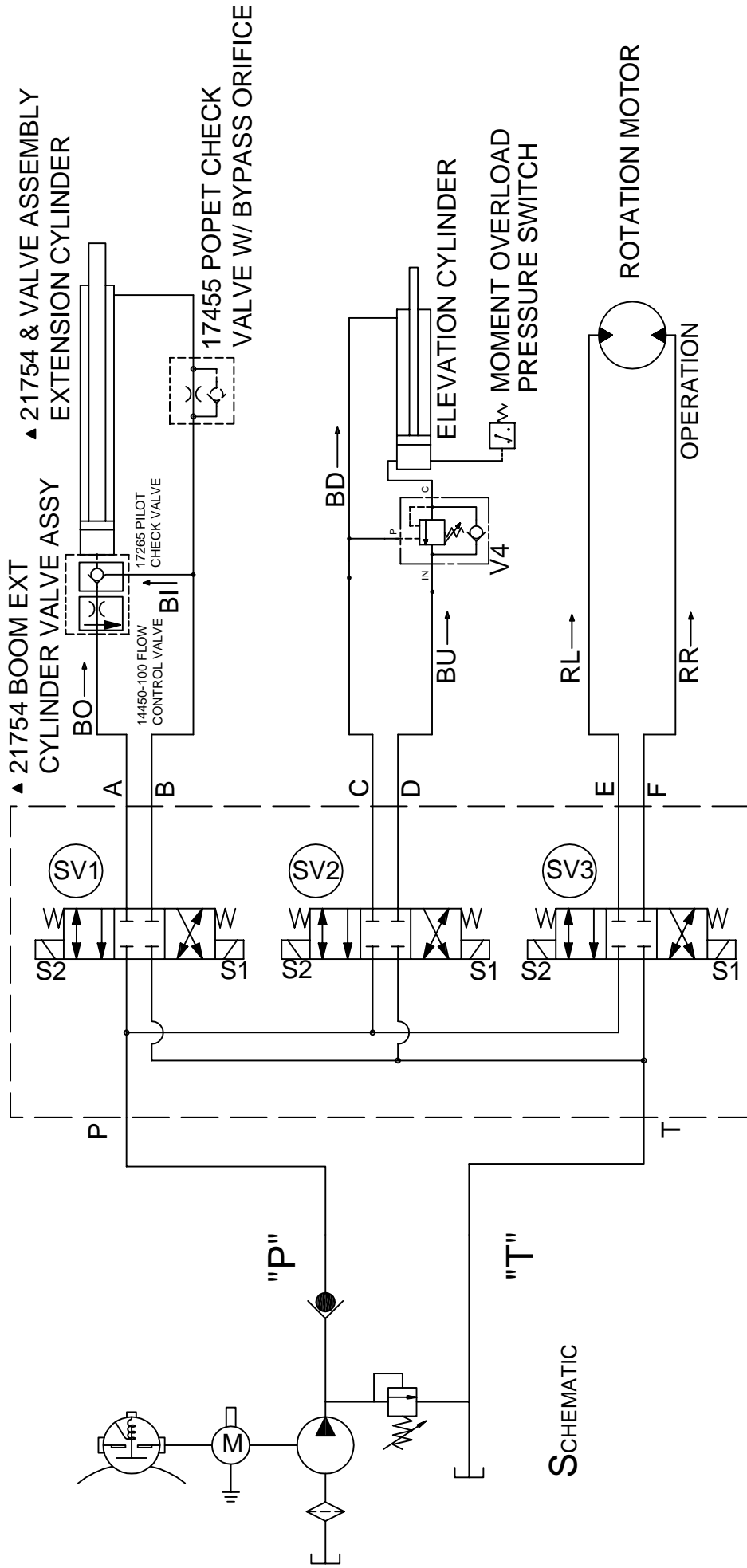

SCHMATIC

▲ NOTE:  
 21754 CYLINDER & SV1 VALVE NOT AVAILABLE ON 'K' SERIES CRANES

- (SV1) ERNERGIZE "S2" OPEN FLOW 'P' TO 'A' 'B' TO 'T' ERNERGIZE "S1" OPEN FLOW 'P' TO 'B' 'A' TO 'T'
- (SV2) ERNERGIZE "S2" OPEN FLOW 'P' TO 'C' 'D' TO 'T' ERNERGIZE "S1" OPEN FLOW 'P' TO 'D' 'C' TO 'T'
- (SV3) ERNERGIZE "S2" OPEN FLOW 'P' TO 'E' 'F' TO 'T' ERNERGIZE "S1" OPEN FLOW 'P' TO 'F' 'E' TO 'T'

		VENCO VENTURO INDUSTRIES LLC CINCINNATI, OHIO	
TITLE HYDRAULIC SYSTEM DIAGRAM			
DATE	03-11-19D	SECTION	C400
SUPERSEDES	01-26-15C		
ET8 (14') & ET12 (15') GEN. 'C' SERIES CRANES		<b>21602</b>	

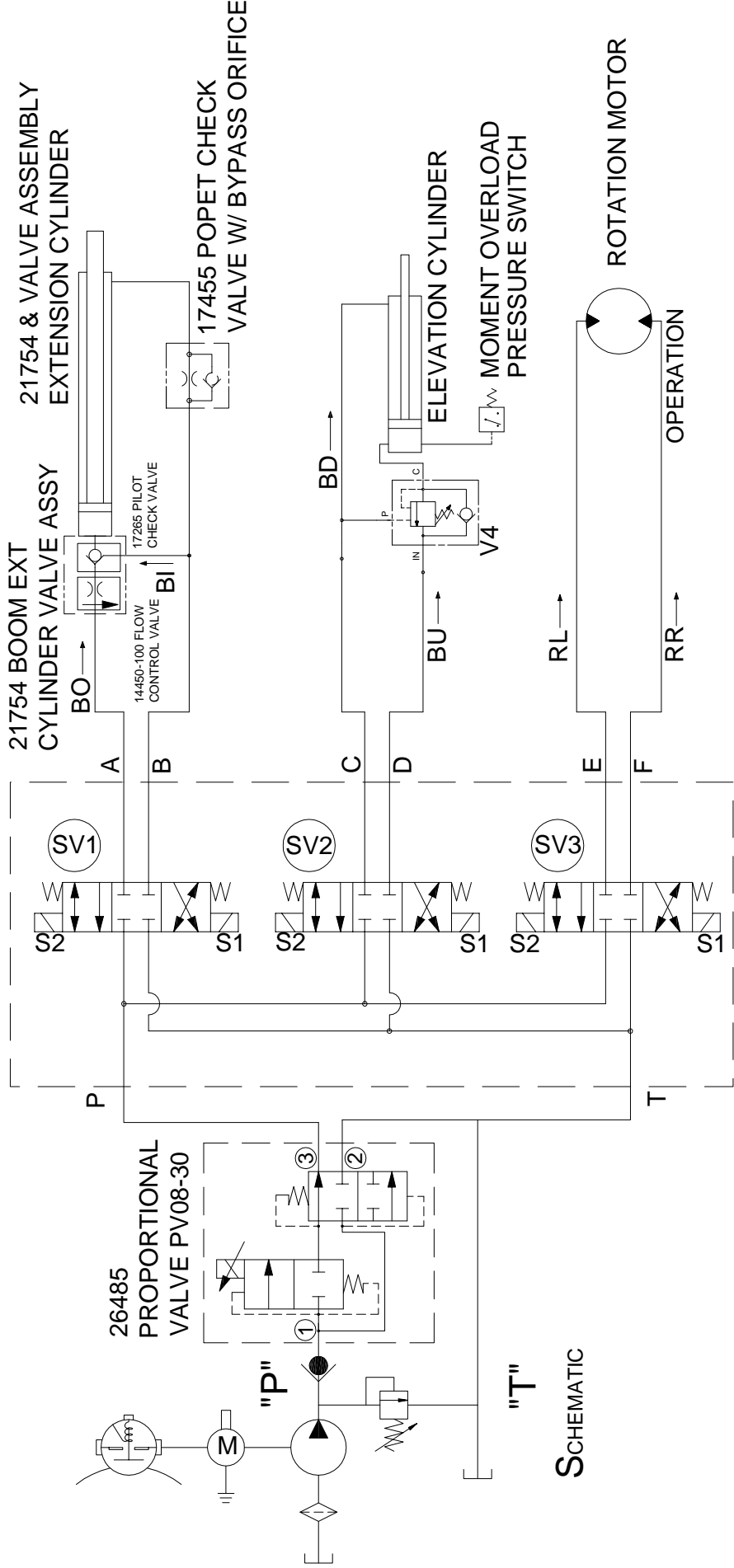

SCHEMATIC

- (SV1) ERNERGIZE "S2" OPEN FLOW 'P' TO 'A' 'B' TO 'T' ENERGEZE "S1" OPEN FLOW 'P' TO 'B' 'A' TO 'T'
- (SV2) ENERGEZE "S2" OPEN FLOW 'P' TO 'C' 'D' TO 'T' ENERGEZE "S1" OPEN FLOW 'P' TO 'D' 'C' TO 'T'
- (SV3) ENERGEZE "S2" OPEN FLOW 'P' TO 'E' 'F' TO 'T' ENERGEZE "S1" OPEN FLOW 'P' TO 'F' 'E' TO 'T'

 <p>VENCO VENTURO INDUSTRIES LLC CINCINNATI, OHIO</p>	TITLE	HYDRAULIC SYSTEM DIAGRAM	
	DATE	03-11-19	SECTION C400
		SUPERSEDES	28077
		ET8KXP (6-10-14), ET12KXP (7-11-15), GEN. 'C'	

# Single & 2-Pole Slip-ring Replacement Parts (1 of 2)

						<b>16780 BILLS OF MATERIALS</b>		
Quill Rotation	Slew Rotation Single Pole Slip-Ring	Slew Rotation 2-Pole Slip-Ring (ET6K ONLY)	Slew Rotation 2-Pole Slip-Ring (ET8-18KX)	Slew Rotation 2-Pole Slip-Ring (ET25-36KX)	ALL CRANES			
16780	16780 - 1	16780 - 2P6	16780 - 2P8	16780 - 2P25	16780 - KIT			
QTY						#	PART	DESCRIPTION
1	1	1	1	1	-	1	16783	PIGTAIL AND STUD ASSEMBLY
1	1	1	1	1	1	2	12534-5	ZINC BUSHING; 5/8" I.D. X 1" O.D. X 14 GAUGE
2	2	2	2	2	2	3	14357-1	FIBER WASHER; 5/8" I.D. X 1 1/16" O.D. X 1/16"
1	1	1	1	1	1	4	14233	INSULATING BUSHING; 5/8" I.D. X 7/8" O.D. X 7/8"
1	-	-	-	-	-	5	14318	FLAT WASHER; 1 3/16" I.D. X 2 3/4" O.D. X 3/16"
1	-	-	-	-	-	6	14232	INVERTED FLARE NUT; 1 3/16"-16
-	-	-	-	-	-	7	27568	WELDED ASSY. CANDLESTICK
1	1	1	1	1	1	8	14357-2	FIBER WASHER; 5/8" I.D. X 1 1/4" O.D. X 1/16"
1	1	1	1	1	1	9	IFWSH-063SAE	FLAT WASHER; 5/8" SAE
-	1	-	-	-	-	10	27156	RUBBER WATER SHIELD; 1/8" THICK
1	1	1	1	1	1	11	ISHCS02528025KC	SET SCREW W/ KNURLED CUP; 1/4"-28 X 1/4"
1	1	1	1	1	1	12	21273	BRASS JAM NUT; 5/8"-11
-	-	-	-	-	-	13	26035-2	PIGTAIL; SWIVEL TERMINAL
-	-	-	-	-	-	14	17012	RUBBER BOOT; SWIVEL TERMINAL
1	1	1	1	1	1	15	5612-162-62	TEFLON WASHER
1	1	1	1	1	1	16	5714-113-62	BRASS WASHER
1	1	1	1	1	1	17	LC-098K-00	SPRING; 0.845" O.D. X 0.098" WIRE X 1.00 F.L.
1	1	1	1	1	1	18	!JNUT-06311N	JAM NUT; 5/8"-11, NYLON NUT
1	1	1	1	1	1	19	LOCTITE-24205	REMOVABLE THREAD LOCKER; 0.5ML
1	1	1	1	1	1	20	19368	IDWG; 16780 SWIVEL TERMINAL
-	-	1	-	-	-	21	27456	UHMW WATER SHIELD, (ET6K ONLY)
-	-	-	1	1	-	22	27456-1	UHMW WATER SHIELD, (ET8 - ET36)
-	-	1	1	1	-	23	27461	SPRING, (-) SLIP-RING ASSY.
-	-	-	1	1	-	24	27441-1	COPPER SLIP-RING, (ET8 - ET36)
-	-	1	-	-	-	25	27441	COPPER SLIP-RING, (ET6K ONLY)
-	-	1	1	1	-	26	27449-1	BRASS SLIP-RING (ET6 - ET36)
-	-	1	1	1	-	27	!HHCS03118075-B	BRASS HHCS
-	-	1	1	1	-	28	!HNUT-03118-B	BRASS NYLOC NUT
-	-	1	-	-	-	29	23255	SLIP-RING, WELDED ASSY, ET6K
-	-	-	1	-	-	30	23255-1	SLIP-RING, WELDED ASSY, ET8 - 18K(X)
-	-	-	-	1	-	31	23255-2	SLIP-RING, WELDED ASSY, ET25 - 36K(X)
-	-	1	1	1	-	32	02025-2*96.5INX	(-) WELDING CABLE ASSY, BRASS SLIP-RING
-	-	1	1	1	-	33	02025-2*22.5INX	(-) WELDING CABLE ASSY, COPPER SLIP-RING
-	-	1	1	1	-	34	27463	SHIM, WIDE RIM, 18GA, 2-1/4 O.D. X 1-1/2 I.D.
-	-	1	1	1	-	35	20889	RUBBER GROMMET
-	-	1	1	1	-	36	!SRNG-150	SNAP-RING, EXTERNAL, 1-1/2"



VENCO VENTURO INDUSTRIES LLC  
CINCINNATI, OHIO

TITLE	DATE	SECTION
16780 REPLACEMENT PARTS	03-29-19A	C400
ET6/8/12/16/18/25/30/36K(X)	SUPERSEDES 04-27-18	21292

# Single & 2-Pole Slip-ring Replacement Parts (2 of 2)

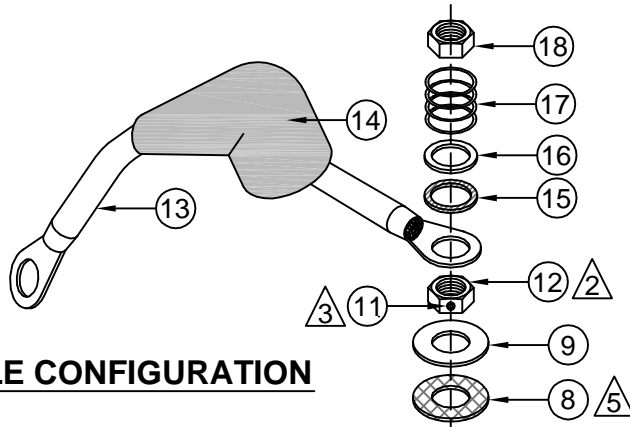

**SINGLE-POLE CONFIGURATION**

**2-POLE CONFIGURATION**

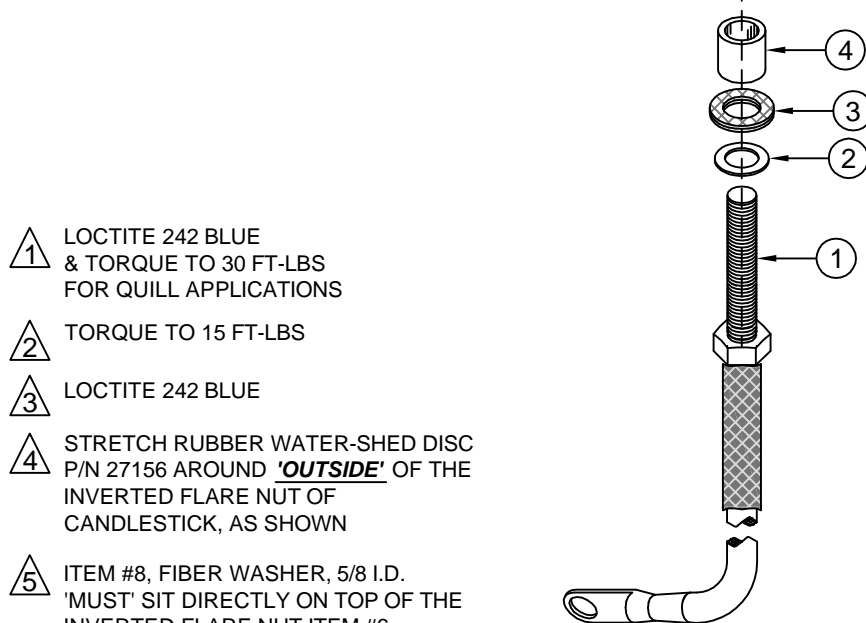
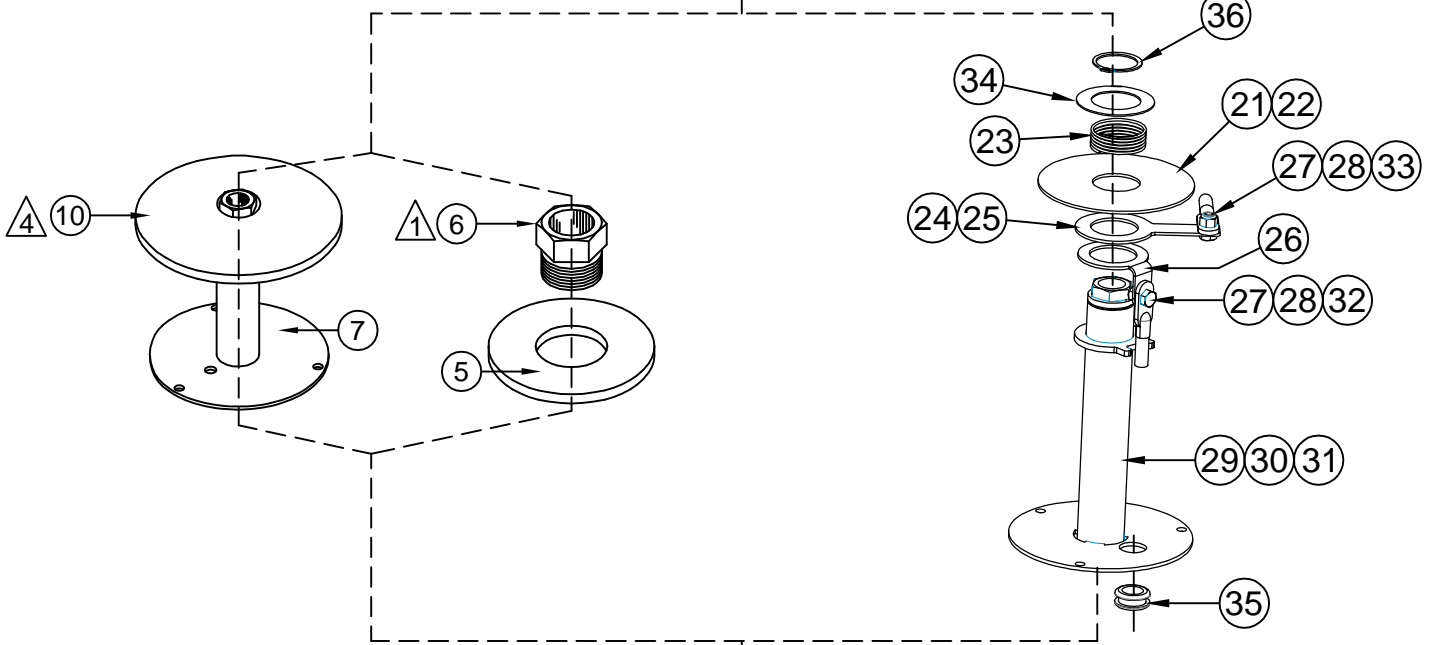

- ① LOCTITE 242 BLUE & TORQUE TO 30 FT-LBS FOR QUILL APPLICATIONS
- ② TORQUE TO 15 FT-LBS
- ③ LOCTITE 242 BLUE
- ④ STRETCH RUBBER WATER-SHED DISC P/N 27156 AROUND **'OUTSIDE'** OF THE INVERTED FLARE NUT OF CANDLESTICK, AS SHOWN
- ⑤ ITEM #8, FIBER WASHER, 5/8 I.D. **'MUST'** SIT DIRECTLY ON TOP OF THE INVERTED FLARE NUT ITEM #6.

THE 16780 SWIVEL TERMINAL CAN REPLACE & INTERCHANGE WITH THE 14231 SWIVEL TERMINAL, FOR ET20,000 & ET20K(X) CRANES.

 VENCIO VENTURO INDUSTRIES LLC CINCINNATI, OHIO	TITLE	DATE	SECTION
	REPL. PARTS ILLUSTRATION	04-27-18	C400
	ET6/8/12/16/18/25/30/36K(X)	SUPERSEDES	21293
		-	

# 21991 PENDANT; 3 FUNCTION ET CRANES, E-STOP / HORN

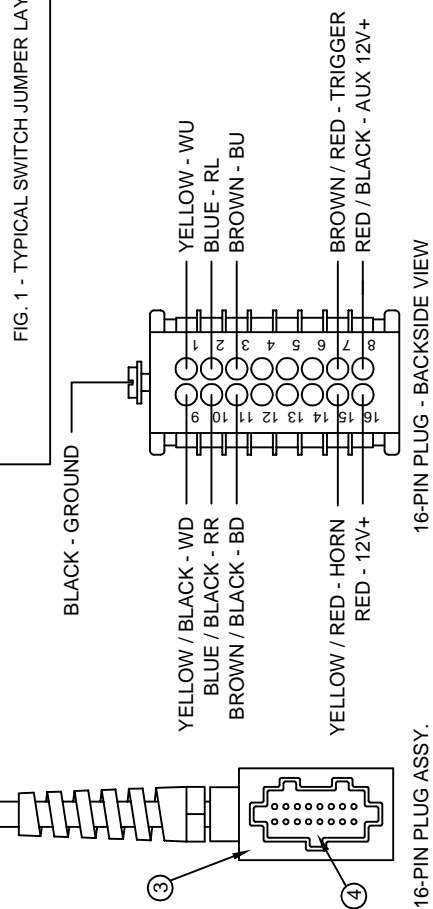
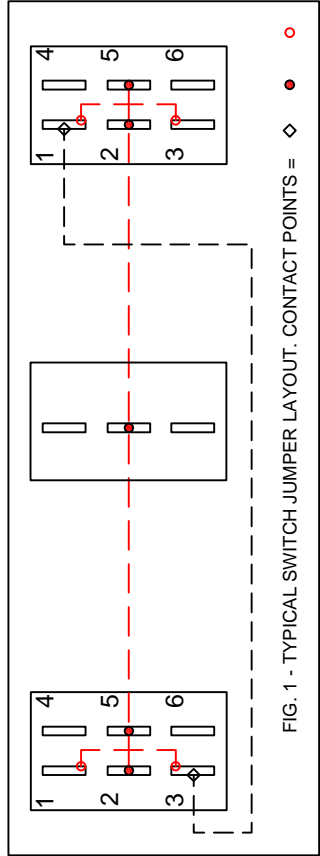
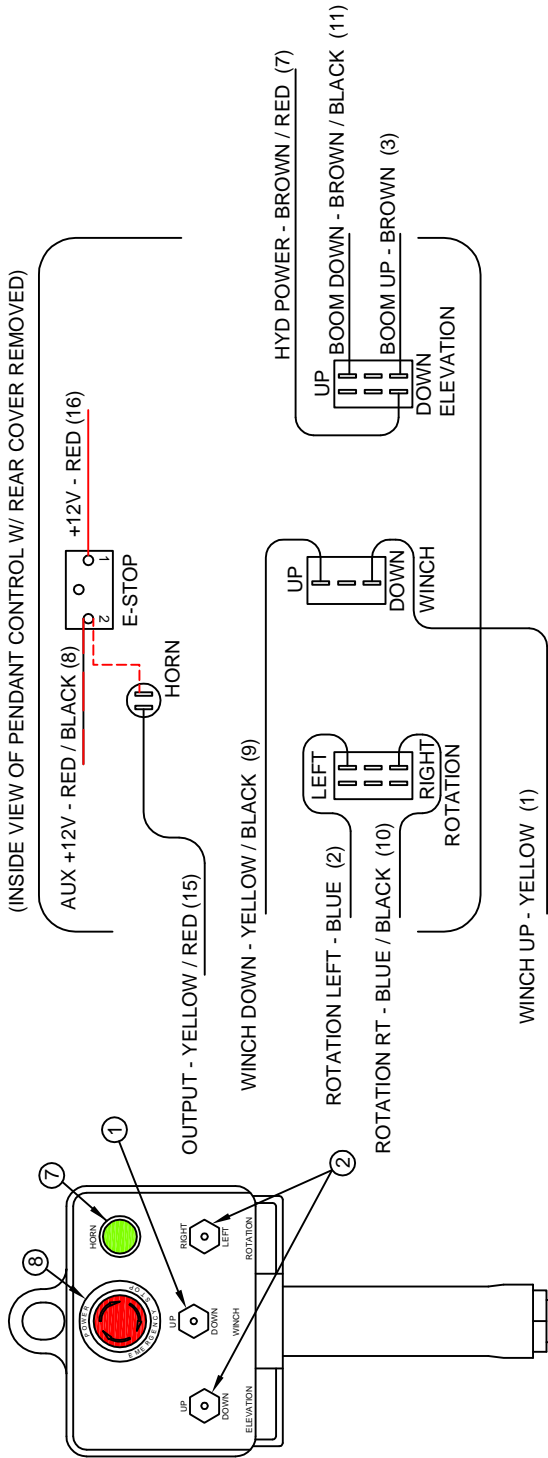

NOTE 1:  
WIRE TERMINALS TO BE INSTALLED 'AFTER'  
ROUTING REPLACEMENT CORD ASSY  
THROUGH PENDANT HEAD AND PLUG  
HOUSING.

NOTE 2:  
STOW OR CUT BACK UNUSED WIRES.

MODEL	STARTING S/N
ET6K	160000
ET8K	45000
ET12K	61800

ITEM	QTY	PART NO.	DESCRIPTION
8	1	22156	SWITCH; E-STOP
7	1	22155	SWITCH; PUSHBUTTON, HORN
6	1	22135	KIT; REPLACEMENT CORD ASSY
5	-	-	-
4	1	22472	INSERT; MALE; 16 + 1 POLE
3	1	22471	PLUG CASE; 16 + 1 POLE
2	2	22152	SWITCH; DPDT, MOMENTARY
1	1	22081	SWITCH; SPDT, MOMENTARY



VENCO VENTURO INDUSTRIES LLC  
CINCINNATI, OHIO

TITLE  
**REPLACEMENT PARTS DWG & LIST**

DATE  
10-03-14

SECTION  
C400

SUPERSEDES  
-

21991 PNDNT; 3 FNCTN ET CRNS, ESTP/HRN

**23076**

# 21990 PENDANT; 4 FUNCTION ET CRANES, E-STOP / HORN

(INSIDE VIEW OF PENDANT CONTROL W/ REAR COVER REMOVED)

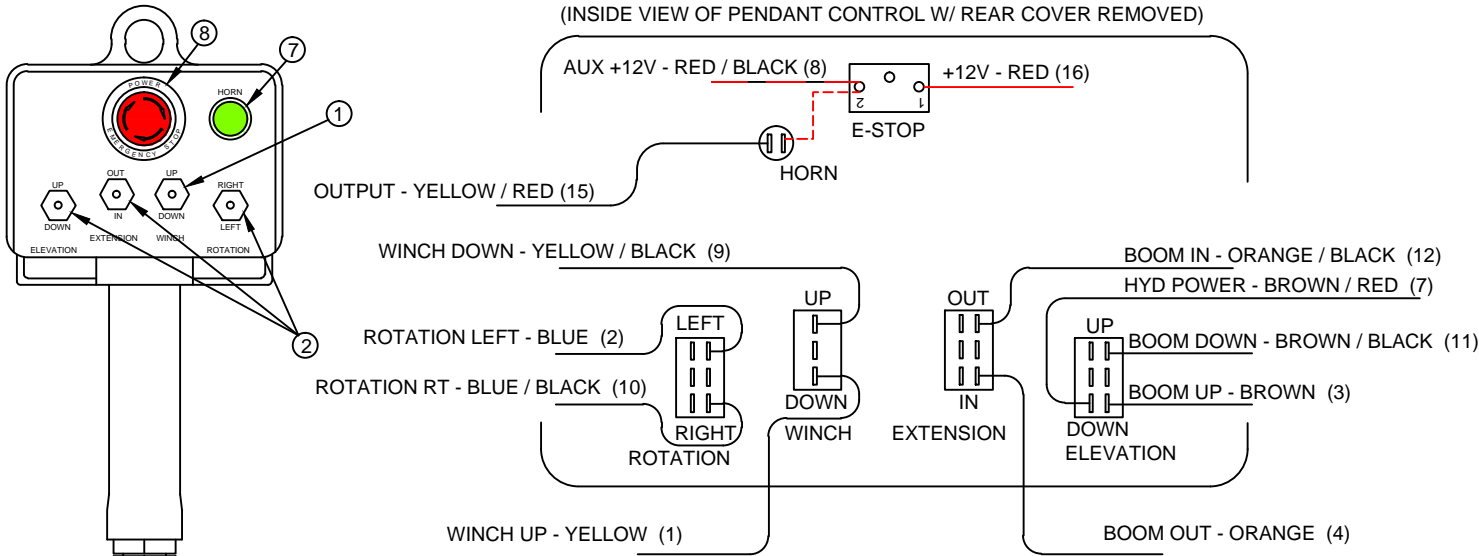

NOTE 1:  
WIRE TERMINALS TO BE INSTALLED 'AFTER'  
ROUTING REPLACEMENT CORD ASSY  
THROUGH PENDANT HEAD AND PLUG  
HOUSING.

NOTE 2:  
STOW OR CUT BACK UNUSED WIRES.

MODEL	STARTING S/N
ET8KX	73800
ET12KX	69800
ET16KX	170000
ET18KX	95900
ET25KX	125300
ET30KX	130300
ET36KXX	140300

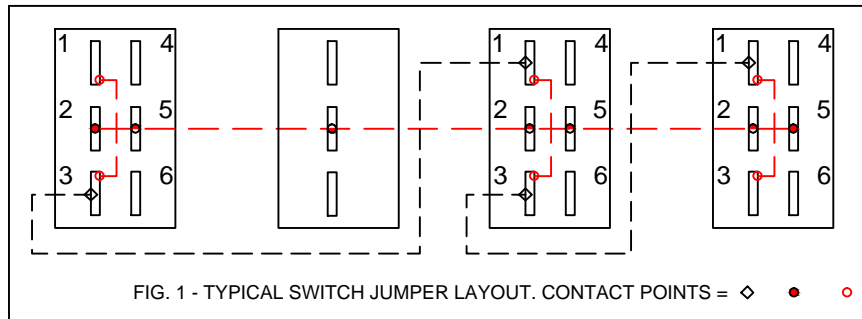
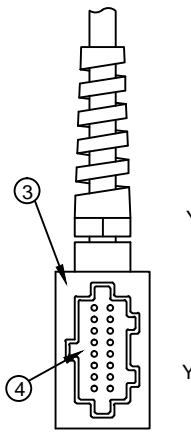

FIG. 1 - TYPICAL SWITCH JUMPER LAYOUT. CONTACT POINTS = ◇ ● ○



16-PIN PLUG ASSY.

16-PIN PLUG - BACKSIDE VIEW

ITEM	QTY	PART NO.	DESCRIPTION
8	1	22156	SWITCH; E-STOP
7	1	22155	SWITCH; PUSHBUTTON, HORN
6	1	22135	KIT; REPLACEMENT CORD ASSY
5	-	-	-
4	1	22472	INSERT; MALE, 16 + 1 POLE
3	1	22471	PLUG CASE; 16 + 1 POLE
2	3	22152	SWITCH; DPDT, MOMENTARY
1	1	22081	SWITCH; SPDT, MOMENTARY



VENCO VENTURO INDUSTRIES LLC  
CINCINNATI, OHIO

TITLE  
REPLACEMENT PARTS DWG & LIST

DATE  
01-12-17B  
SECTION  
C400

21990 PNDNT; 4 FNCTN ET CRNS, ESTP/HRN

SUPSEDES  
10-20-14A

23075



# 22158 RADIO; PROP, NON-CAN, NO ENG CNTRLS, E-STOP/HORN

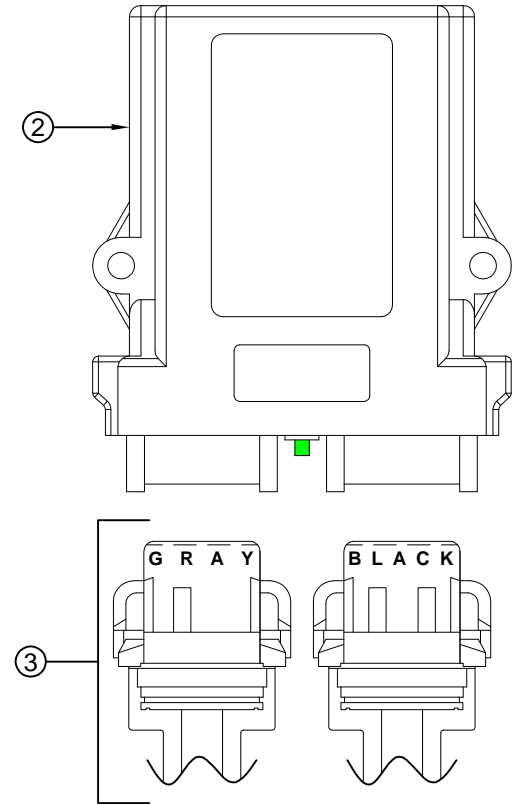
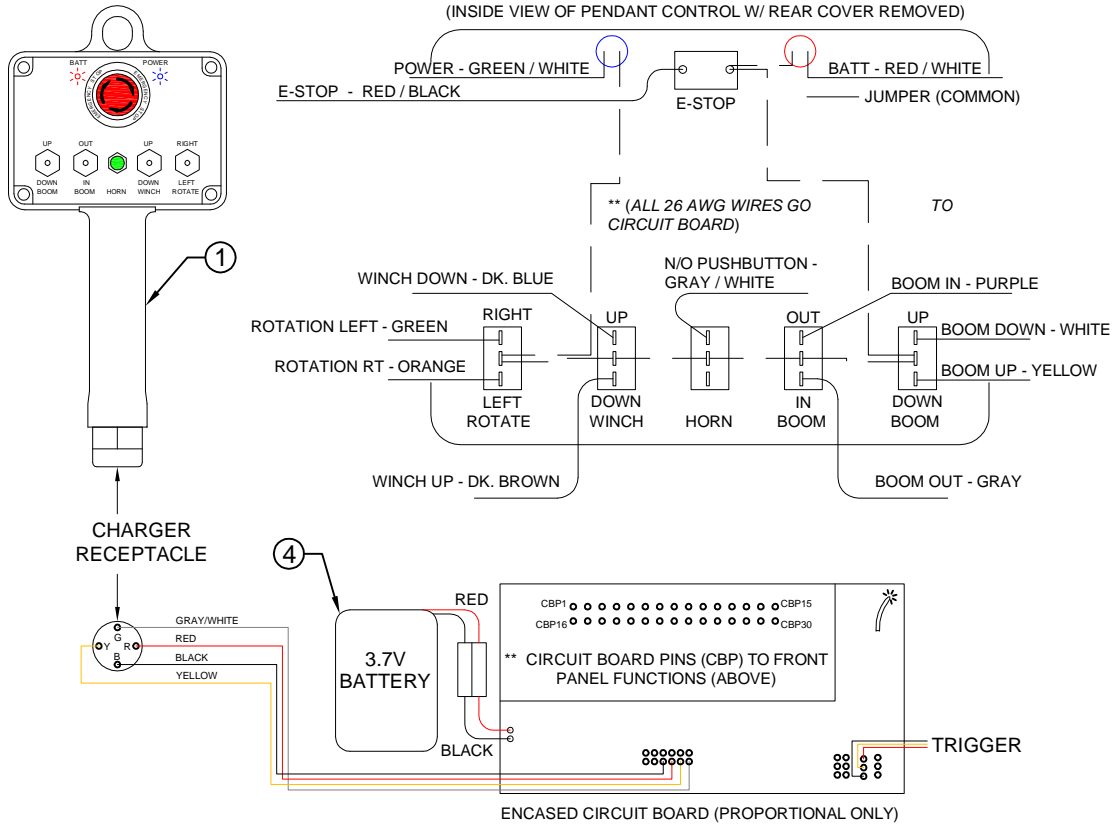

CABLE 1 = GRAY CONNECTOR  
CABLE 2 = BLACK CONNECTOR

16-PIN PLUG - BACKSIDE VIEW

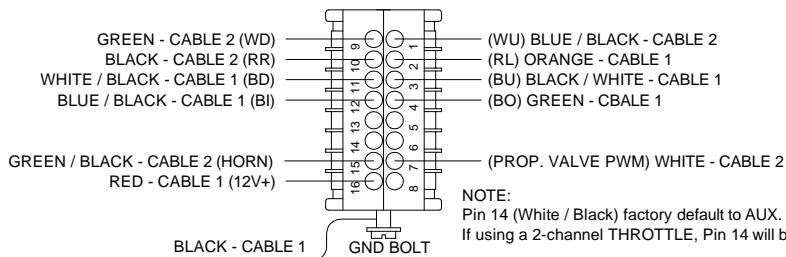

NOTE:  
Pin 14 (White / Black) factory default to AUX. ON/OFF  
If using a 2-channel THROTTLE, Pin 14 will be THROTTLE DOWN.

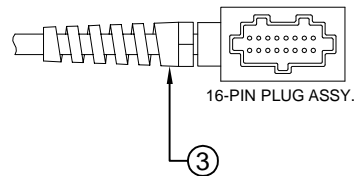

COMPONENTS		
ITEM NO.	PART NO.	DESCRIPTION
1	22158-TX	TRANSMITTER
2	22158-RX	RECEIVER
3	21983-HN	HARNESS
4	22965-BATT	BATTERY
5	22965-CHGR	CHARGER (NOT SHOWN)



VENCO VENTURO INDUSTRIES LLC  
CINCINNATI, OHIO

TITLE  
REPLACEMENT PARTS DWG & LIST

ET PROPORTIONAL SERIES CRANES ▲

DATE  
03-11-19A

SUPERSEDES  
07-31-18

SECTION  
C400

23786

# 21556 WINCH REPLACEMENT PARTS

## WARN DC1600

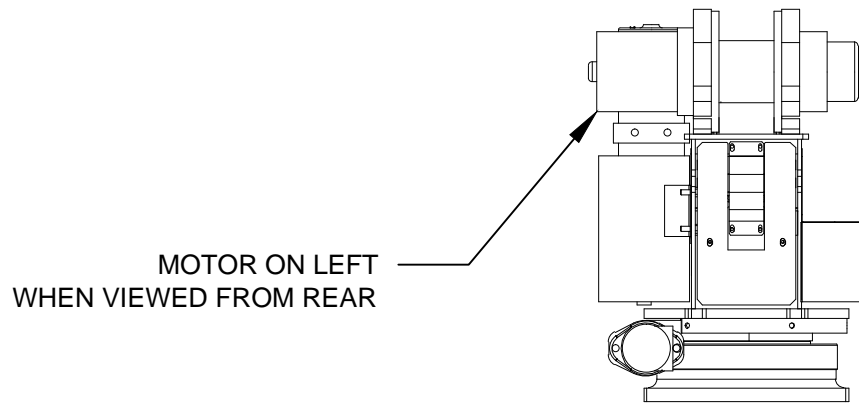

## COMEUP GTD-2200

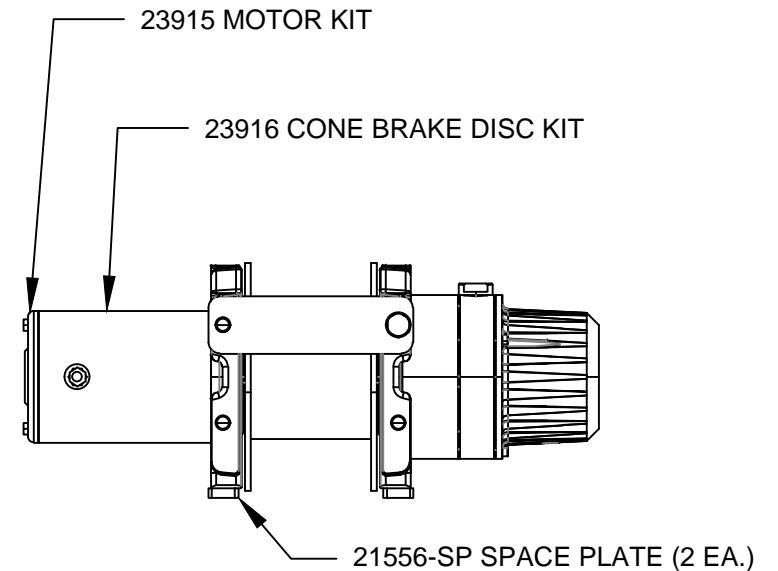
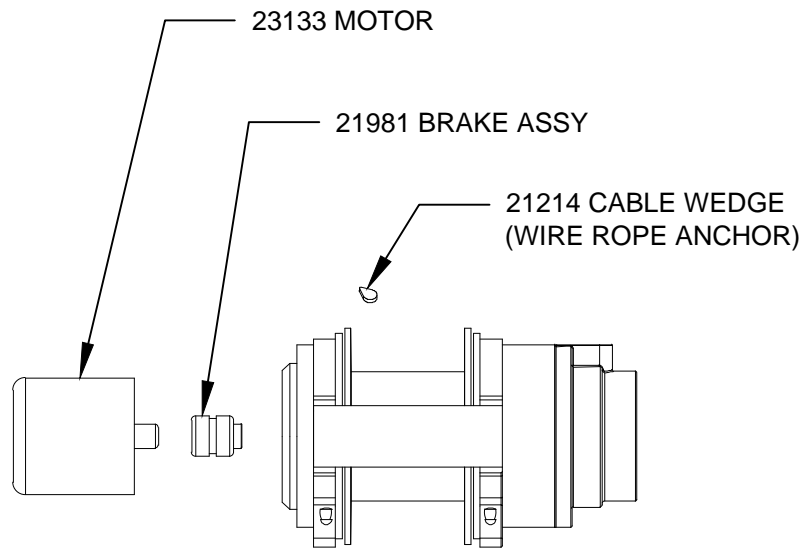
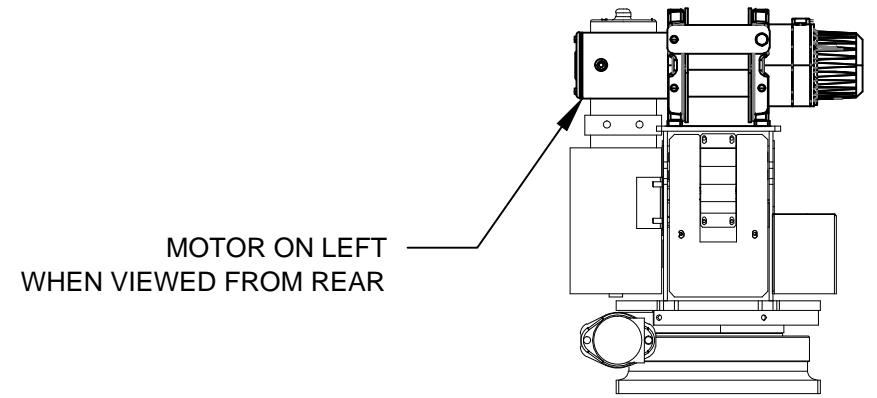

MANUFACTURING, INC.  
CINCINNATI, OHIO

TITLE  
WINCH REPLACEMENT PARTS (DC1600)  
ET8/12K(X)

DATE  
10-24-22E  
SUPERSEDES  
06-16-22D

SECTION  
C400  
21741

# 20873 HYDRAULIC POWER UNIT (H.P.U.)

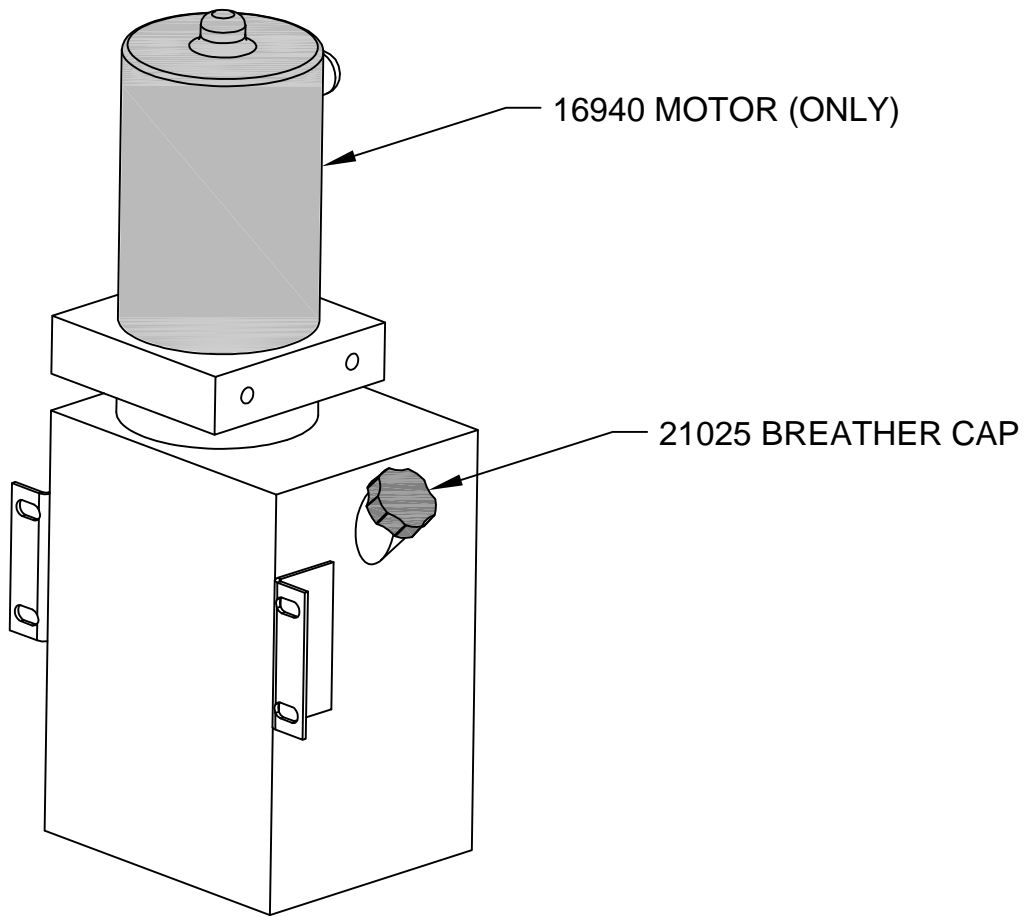

NOTE:  
HYDRAULIC POWER UNIT SETTINGS ARE AS FOLLOWS:

- ▲ ET8/12K(X) PRESSURE = 2600 PSI



VENCO VENTURO INDUSTRIES LLC  
CINCINNATI, OHIO

TITLE

H.P.U. RPLCMNT PARTS

DATE

01-26-15B

SECTION

C400

ET8/12K(X) ▲

SUPERSEDES

12-27-13A

16942

# 21735 SLEWING SYSTEM REPLACEMENT PARTS

21123 MOTOR (ONLY)

21218 - MOTOR SEAL KIT

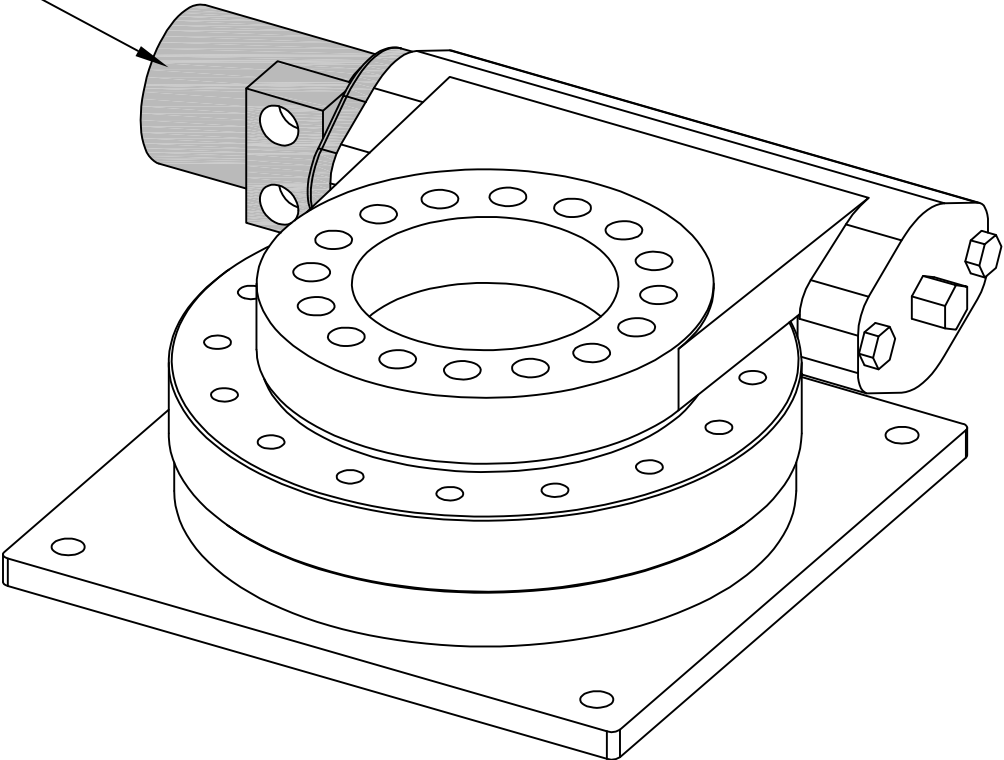

VENCO VENTURO INDUSTRIES LLC  
CINCINNATI, OHIO

TITLE	DATE	SECTION
SLEWING SYSTEM REPLACEMENT PARTS	10-23-14B	C400
ET8/12K & ET8/12/16/18KX ▲	SUPERSEDES 12-27-13A	21973

LEFT

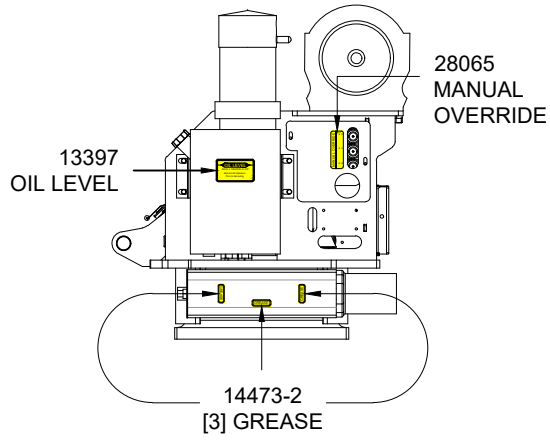

BACK

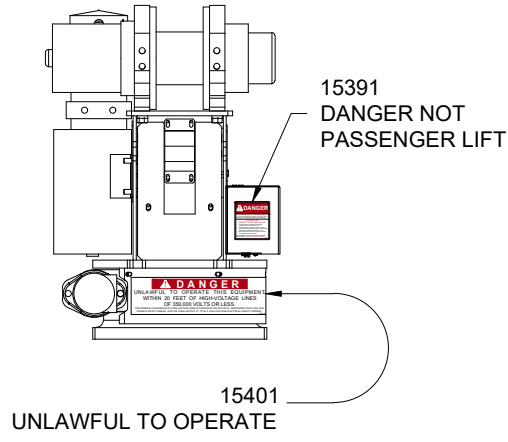

RIGHT

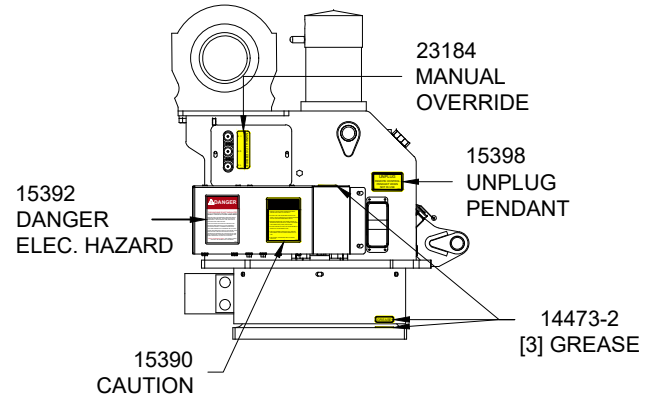

### ET 8 SERIES

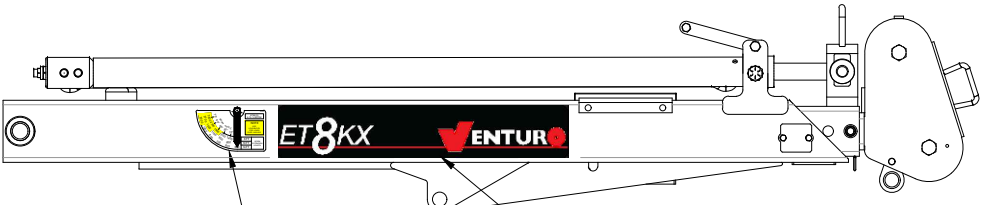

CAPACITY		
DECAL	MODEL	PART #
RIGHT	ET8K(X)	21702
LEFT	ET8K(X)	21703

28540 DECAL MODEL

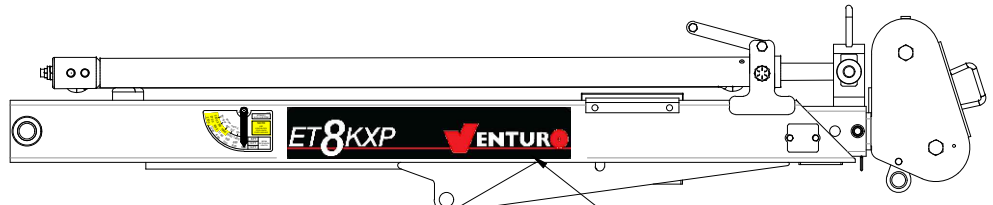

28541 DECAL MODEL

### ET12 SERIES

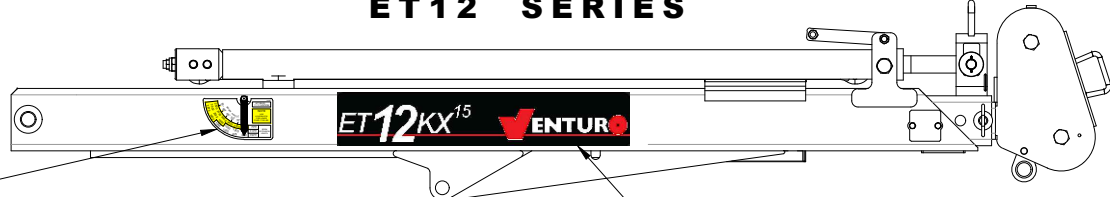

CAPACITY		
DECAL	MODEL	PART #
RIGHT	ET12KX	21576
LEFT	ET12KX	21577

28550 DECAL MODEL



VENCO VENTURO INDUSTRIES LLC  
CINCINNATI, OHIO

TITLE  
DECAL PLACEMENT

ET8 & ET12-15' SERIES

DATE  
11-14-23

SUPERSEDES  
-

SECTION  
C400

28543

# FIELD SERVICE LABEL KIT; ET12KX-15'

21586; FIELD SERVICE LABEL KIT, ET12KX		
SERIAL RANGE: 68900 - CURRENT		
PART #	QTY	DESCRIPTION
14473-2	6	DECAL; GREASE
28550	2	DECAL; VENTURO, ET12-15'
21576	1	DECAL; BOOM CAPACITY, ET12 SERIES, RIGHT
21577	1	DECAL; BOOM CAPACITY, ET12 SERIES, LEFT
13397	1	DECAL; OIL LEVEL
28065	1	DECAL; MANUAL OVERRIDE, RIGHT
23184	1	DECAL; MANUAL OVERRIDE, LEFT
17813	1	DECAL; OVERLOAD SENSING SYSTEM
16184-1	1	DECAL; HORN RELAY
28552	1	IDWG; FIELD SERVICE LABEL KIT LIST
28543	1	IDWG; DECAL PLACEMENT
INST-23233	1	SAFETY MANUAL, VENTURO CRANES
15397	1	KIT; ACCIDENT PREVENTION SIGNS



VENCO VENTURO INDUSTRIES LLC  
CINCINNATI, OHIO

TITLE  
FIELD SERVICE LABEL KIT  
ET12KX-15'

DATE  
11-15-23  
SUPERSEDES  
-

SECTION  
C400  
28552





## VENTURO CRANES LIMITED WARRANTY POLICY

Venturo products are built to last...we guarantee them.

As a purchaser of any new Venturo product covered by warranty, you will receive 1 year of the most complete coverage available...and, at no added cost to you.

### 1-Year Limited Warranty Policy

This limited policy warrants new products of Venturo to be free from defects in material and workmanship for a period of one (1) year from date of original installation. OEM products or accessories purchased by Venturo as part of or offered with our product will carry the OEM manufacturer's respective warranty. Our warranty covers:

- ***Repair or replacement of product***
- ***Labor to repair or replace product***
- ***Freight to return and/or replace product***

We shall not be liable for any contingent liabilities arising out of the improper function of any products. Warranty shall become void if the product is improperly installed, modified, damaged, abused or used for application other than intended use. There is no warranty of merchantability, fitness for a particular purpose, warranty arising from course of dealing or usage of trade, or any other implied or expressed warranty, except as made specifically herein. This warranty supersedes all previous warranties, written or implied.

### Warranty Claims

Venco Venturo Industries LLC will make a good faith effort for prompt correction or other adjustment with respect to any product, which proves to be defective after our inspection and within the warranty period. Before any repairs are attempted or before returning any product, your Venturo Distributor is required to obtain a warranty claim number. This number is necessary for any claim to be considered. To obtain a warranty claim number, Venturo requires the model and serial number. Only authorized Venturo Distributors can perform warranty. For the name and address of your local Venturo Distributor call the **Warranty Claim Department - 513-772-8448**.

**WARNING** - It is the responsibility of the installer to ensure the installation is completed according to the manufacturer's recommendations, ensure the ultimate user understands how to operate product in a safe manner, and understands the need for regular service and maintenance by an authorized Venturo Distributor. No modifications or alterations may be made to any Venturo product without the expressed written consent of Venco Venturo Industries LLC. Installation of any Venturo product must be done by an authorized Venturo Distributor, to the standards of the industry; including maintenance, service and affixing of all instruction, safety and warning decals. Users should be instructed as to the safe operation at time of delivery. Maintenance, service, operation and safety warning decals are available on request from Venco Venturo Industries LLC.

**VENCO VENTURO INDUSTRIES LLC**  
12110 BEST PLACE | CINCINNATI, OHIO 45241  
P: 800-226-2238 | F: 513-326-5427  
[www.venturo.com](http://www.venturo.com)