

PARTS & INSTALLATION MANUAL

HT45KX-25

Included in this manual:

HT45KX-25 (VLC)

- 7,800 lb Hydraulic Telescopic Service Crane
- Venturo Logic Control System w/ Proportional Control
- 25 ft Fully-Powered, Two-Stage Boom Extension

HT45KX-25' VLC

INST-26916 - 11/11/2024 (Rev: NEW5)

7607100A	SECTION 100: DESCRIPTION & SPECIFICATIONS
26893	INSTALLATION DIMENSIONS
26892	MOUNTING DIMENSIONS
24249	CAPACITY CHART; HT45KX (25' BOOM)
7607150A	SECTION 150: SAFETY
15394	VEHICLE & CRANE ELECTRICAL HAZARD INFORMATION
920612	SAFETY & HAZARDS, GENERAL
19217	WINCH SAFETY WARNINGS
22181A	SAFETY DECALS DRAWING & LIST
22181B	SAFETY DECALS DRAWING & LIST
22181C	SAFETY DECALS DRAWING & LIST
28526	SAFETY DECALS DRAWING & LIST
23749	BOOM CAPACITY DECALS; HT45 SERIES
23748	DECALS; VENTURO LOGIC CONTROLS (VLC)
7607200A	SECTION 200: INSTALLATION
26900	CRANE INSTALLATION (PAGE 1 OF 2)
23752	CRANE INSTALLATION (PAGE 2 OF 2)
20051	ROTATION STOP LOCATION
20906-45	HT45KX 25' BOOM STABILITY TESTING
20907	STABILITY CHART
22825	22785 HYDRAULIC TANK DIMENSIONS
22883	HYDRAULIC COMPONENT INSTALLATION
23015	CONNECTIONS GUIDE (PAGE 1 OF 2)
23014	CONNECTIONS GUIDE (PAGE 2 OF 2)
22913	CONNECTIONS GUIDE (PAGE 3 OF 3)
22245	WIRE ROPE INSTALLATION
7607300B	SECTION 300: OPERATION & MAINTENANCE
23203	MAINTENANCE OVERVIEW INFORMATION
23753	CRANE OPERATION & MAINTENANCE INSTRUCTIONS (PAGE 1 OF 3)
23754	CRANE OPERATION & MAINTENANCE INSTRUCTIONS (PAGE 2 OF 3)
23755	CRANE OPERATION & MAINTENANCE INSTRUCTIONS (PAGE 3 OF 3)
22168	SAFETY SHUTOFF INSTRUCTIONS
23231	WIRE ROPE & HOOK SPECIFICATIONS
7607400A	SECTION 400: REPLACEMENT PARTS
26901	REPLACEMENT PARTS DRAWING; MECHANISM
26902	REPLACEMENT PARTS LIST; MECHANISM
26903	REPLACEMENT FASTENER DRAWING; MECHANISM
26904	REPLACEMENT FASTENER LIST; MECHANISM
23860	REPLACEMENT PARTS DRAWING; 23107 BOOM
23861	REPLACEMENT PARTS LIST; 23107 BOOM
23862	REPLACEMENT FASTENER DRAWING; 23107 BOOM
23863	REPLACEMENT FASTENER LIST; 23107 BOOM
28239	A2B STOWAGE CUT-OUT
26896	REPLACEMENT PARTS DIAGRAM; T11 & T12 WINCH
23864	REPLACEMENT PARTS DRAWING; HYDRAULIC COMPONENTS
23865	REPLACEMENT PARTS LIST; HYDRAULIC COMPONENTS
22940	REPLACEMENT PARTS DIAGRAM; 22736H HYDRAULIC VALVE MANIFOLD
28188	WORK LIGHT INSTALLATION INSTRUCTIONS; COMPACT A2B MOUNT
23436	WIRING DIAGRAM, PG. 1
23437	WIRING DIAGRAM, PG. 2
23868	HYDRAULIC SYSTEM DIAGRAM
22615	ENGINE START/STOP/THROTTLE CONTROLS
28527	DECAL PLACEMENT
23224	RESERVOIR KITS; REPLACEMENT PARTS DRAWING & LISTS
23766	23739 FIELD SERVICE LABEL KIT, HT45KX

12-00073_VNT1 WARRANTY PAGE

SECTION 100

DESCRIPTION

&

SPECIFICATIONS



VENCO VENTURO INDUSTRIES LLC
CINCINNATI, OHIO

WARNING

- These products are not passenger lifts. They are not designed or intended to be used to lift, support, or otherwise transport personnel.

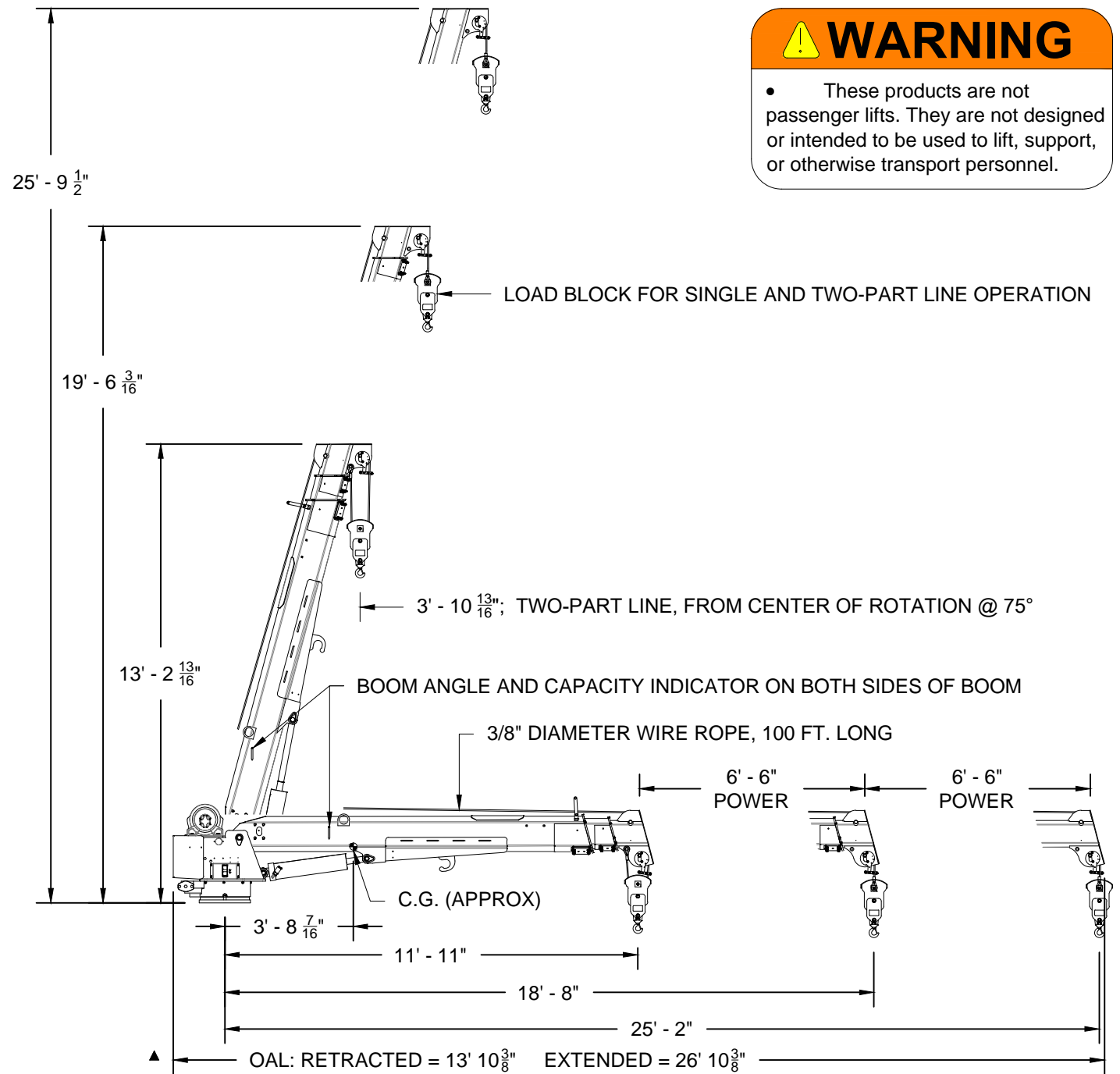
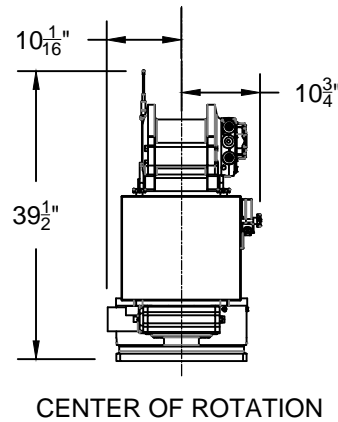
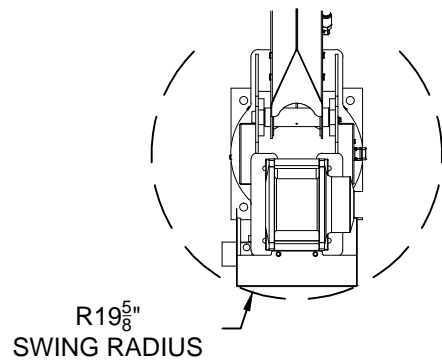

VENCO VENTURO INDUSTRIES LLC
CINCINNATI, OHIO

TITLE
INSTALLATION DIMENSIONS

HT40/45/50KX-25' BOOM

DATE
10-03-24A

SUPERSEDES
05-25-23

SECTION
C100

26893

HT40/45/50KX SERIES MOUNTING DIMENSIONS

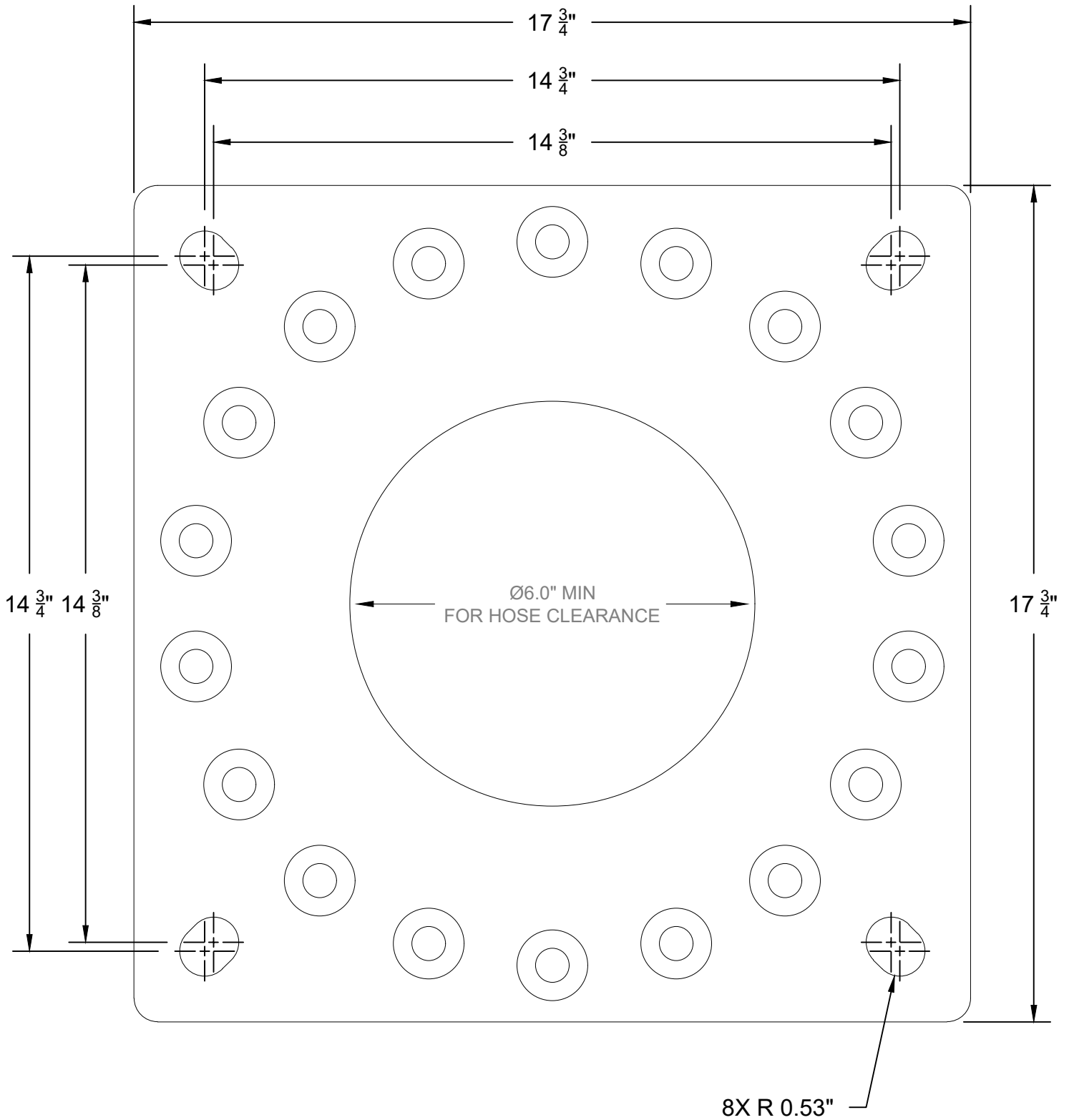

VENCO VENTURO INDUSTRIES LLC
CINCINNATI, OHIO

TITLE
MOUNTING DIMENSIONS

HT40/45/50KX SERIES

DATE
09-03-24A

SUPERSEDES
05-25-23

SECTION
C100

26892

HT45KX, 12' - 18.5' - 25' BOOM, WITH VENTURO LOGIC CONTROL SYSTEM
AND 7,800 LB CAPACITY

CRANE SERIAL NUMBER: _____

MAXIMUM LOAD CAPACITY CHART

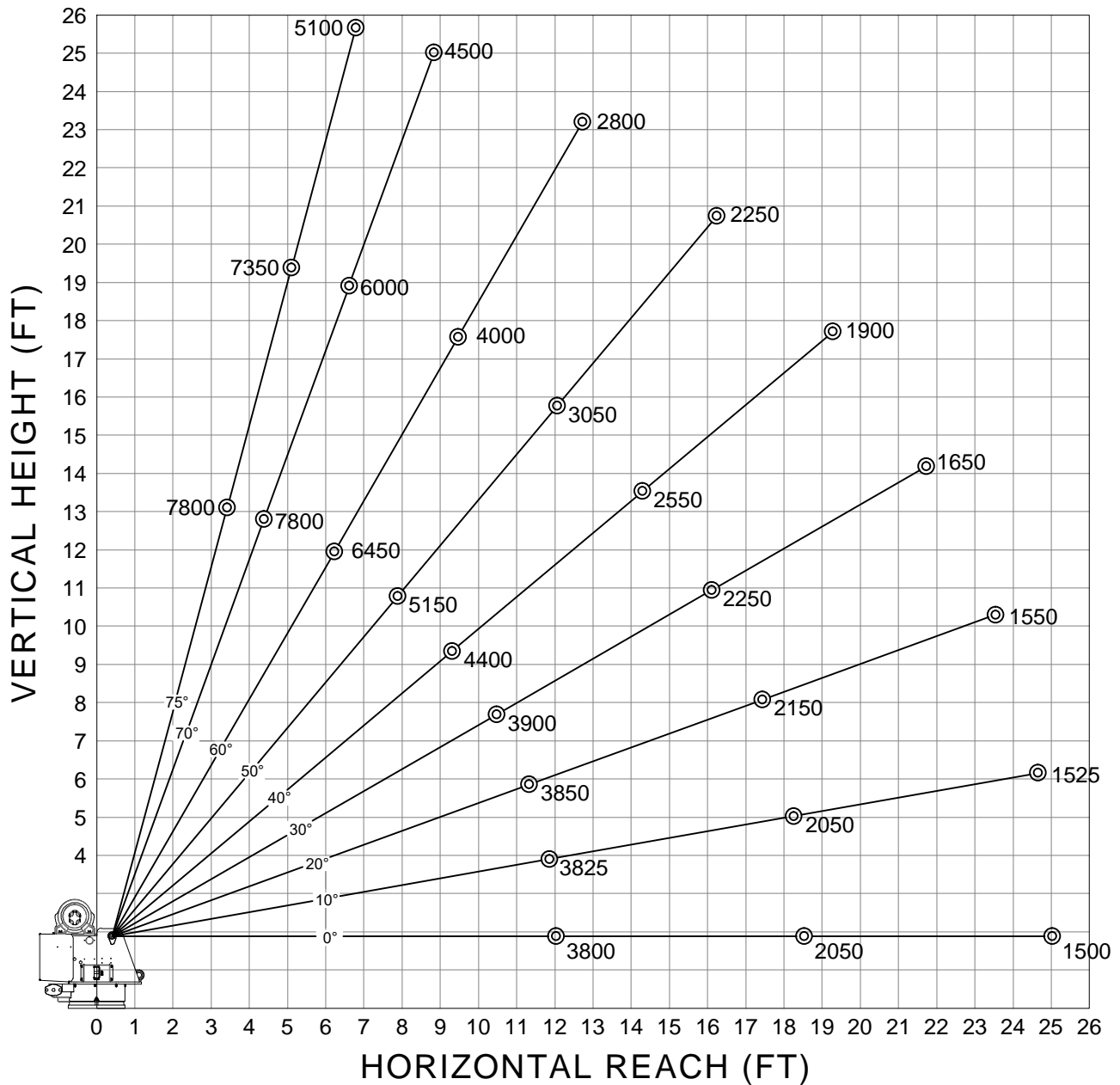

WEIGHT OF LOAD HANDLING DEVICES ARE PART OF THE LOAD AND MUST BE DEDUCTED FROM THE GROSS CAPACITY.

LOAD BLOCK USAGE

1-PART LINE FOR LOADS LESS THAN 3000 LBS

2-PART LINE FOR LOADS OF 3000 LBS AND GREATER

WEIGHT OF LOAD BLOCK = 51 LBS



VENCO VENTURO INDUSTRIES LLC
CINCINNATI, OHIO

TITLE	DATE	SECTION
MAXIMUM LOAD CAPACITY	05-02-22A	C100
HT45KX-25', VLC, 7,800 LB CAP.	SUPERSEDES 10-11-18	24249

DATE	SECTION
05-02-22A	C100
SUPERSEDES 10-11-18	24249

SECTION 150

SAFETY



VENCO VENTURO INDUSTRIES LLC
CINCINNATI, OHIO

VEHICLE & CRANE MOUNTED ELECTRICAL HAZARD SIGN APPLICATION & INFORMATION

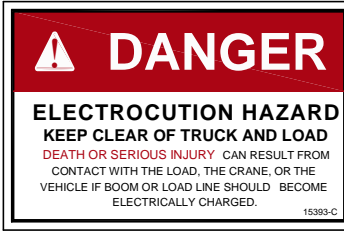

SIGN NO. 15393 DISPLAYS THE INTERNATIONAL SYMBOL FOR ELECTRICITY AND WARNS OF DANGER FROM AN ELECTRICALLY CHARGED VEHICLE, CRANE, OR LOAD. FOUR ARE RECOMMENDED (ONE FOR EACH SIDE AND ONE FOR EACH END OF VEHICLE) TO BE APPLIED IN LOCATIONS WHICH ARE READILY VISIBLE TO GROUND PERSONNEL.

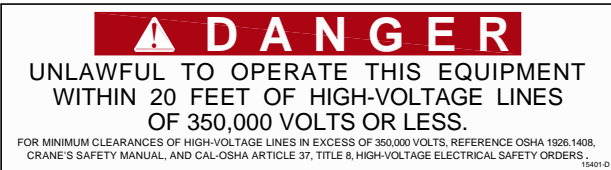

SIGN NO. 15401 PROVIDES ADDITIONAL WARNING OF LEGAL REQUIREMENTS WHEN OPERATING NEAR HIGH VOLTAGE LINES. THIS SIGN IS PLACED ON THE CONTROL PENDANT SIDE OF BOOM.

Table A - Minimum Clearance Distances

Voltage (nominal, kV, alternating current)	Minimum clearance distance (feet) *
Up to 50.....	10
over 50 - 200.....	15
over 200 - 350.....	20
over 350 - 500.....	25
over 500 - 750.....	35
over 750 - 1000.....	45
Over 1000.....	(as established by the utility owner/operator or registered professional engineer who is a qualified person with respect to electrical power transmission and distribution).

Table T - Minimum Clearance Distances While Traveling With No Load

Voltage (nominal, kV, alternating current)	While traveling - minimum clearance distance (feet) *
0 - 0.75.....	4
over 0.75 - 50.....	6
over 50 - 345.....	10
over 345 - 750.....	16
over 750 - 1000.....	20
Over 1000.....	(as established by the utility owner/operator or registered professional engineer who is a qualified person with respect to electrical power transmission and distribution).

* NOTE: ENVIRONMENTAL CONDITIONS SUCH AS FOG, SMOKE, OR PRECIPITATION MAY REQUIRE INCREASED CLEARANCES



VENCO VENTURO INDUSTRIES LLC
CINCINNATI, OHIO

TITLE	DATE	SECTION
HAZARD APPS & INFO	02-21-14M	C150
ET/HT CRANES	SUPERSEDES 12-20-13L	15394

CRANE SAFETY AND HAZARDS

HT SERIES CRANES

CAUTIONS

1. INSPECT VEHICLE AND CRANE, INCLUDING OPERATION, PRIOR TO USE DAILY.
2. DO NOT USE THIS EQUIPMENT EXCEPT ON SOLID, LEVEL SURFACE WITH CRANE MOUNTED ON FACTORY-RECOMMENDED TRUCK.
3. BEFORE OPERATING THE CRANE, REFER TO MAXIMUM LOAD (CAPACITY) CHART ON CRANE FOR OPERATING (LOAD) LIMITATIONS.
4. DO NOT OPERATE, WALK, OR STAND BENEATH BOOM OR A SUSPENDED LOAD.
5. ATTACH PENDANT CORD SUPPORT SNAP TO ATTACHMENT POINT BEFORE PLUGGING IN PENDANT.
6. UNPLUG PENDANT AND DISENGAGE PTO SYSTEM WHEN CRANE NOT IN USE.
7. FOR TRAVEL, BOOM MUST BE IN STOWED POSITION.

DANGER

- THIS CRANE IS NOT A PASSENGER LIFT
- IT IS NOT DESIGNED OR INTENDED TO BE USED TO LIFT, SUPPORT, OR OTHERWISE TRANSPORT PERSONNEL.

YOU MUST NOT OPERATE THIS CRANE UNLESS

1. YOU HAVE BEEN TRAINED IN THE SAFE OPERATION OF THIS CRANE
AND
2. YOU KNOW AND FOLLOW THE SAFETY AND OPERATING RECOMMENDATIONS CONTAINED IN THE MANUFACTURER'S MANUALS, YOUR EMPLOYER'S WORK RULES, AND APPLICABLE GOVERNMENT REGULATIONS. AN UNTRAINED OPERATOR SUBJECTS HIMSELF AND OTHERS TO DEATH OR SERIOUS INJURY.

ELECTROCUTION HAZARD

- THIS MACHINE IS NOT INSULATED.
- MAINTAIN SAFE CLEARANCES FROM ELECTRICAL LINES AND APPARATUS.
- YOU MUST ALLOW FOR BOOM SWAY, ROCK OR SAG, AND ELECTRICAL LINE AND LOADLINE SWAYING.
- THIS LIFTING DEVICE DOES NOT PROVIDE PROTECTION FROM CONTACT WITH OR PROXIMITY TO AN ELECTRICALLY CHARGED CONDUCTOR.
- YOU MUST MAINTAIN A CLEARANCE OF AT LEAST 20 FEET BETWEEN ANY PART OF THE CRANE, LOADLINE, OR LOAD, AND ANY ELECTRICAL LINE OR APPARATUS CARRYING UP TO 350 kV (SEE NEW CHART). ADDITIONAL CLEARANCES ARE REQUIRED FOR VOLTAGES IN EXCESS OF 50,000 VOLTS. REFER TO DRAWING 15394 FOR ADDITIONAL INFORMATION.
- **DEATH OR SERIOUS INJURY** WILL RESULT FROM CONTACT OR INADEQUATE CLEARANCE.



VENCO VENTURO INDUSTRIES LLC
CINCINNATI, OHIO

TITLE	DATE	SECTION
CRANE SAFETY & HZRDS	02-21-14D	C150
HYDRAULIC CRANES	SUPERSEDES 04-04-12C	920612

WINCH SAFETY WARNINGS

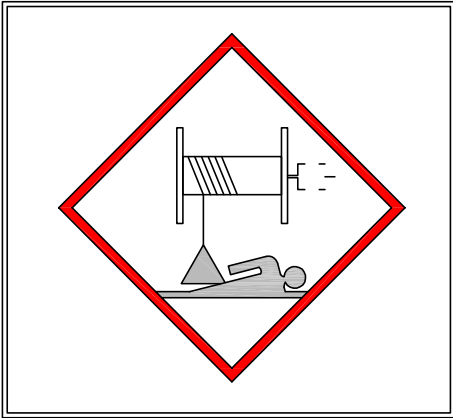

DANGER

- DO NOT DISENGAGE WINCH UNDER LOAD

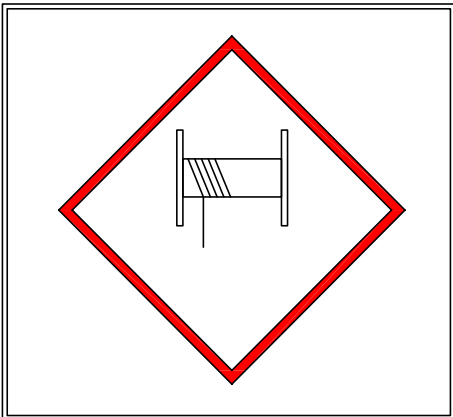

DANGER

- THE LAST [5] (DEAD) WRAPS OF WIRE ROPE MUST BE LEFT ON TO ASSIST WIRE ROPE CLAMP IN HOLDING LOAD

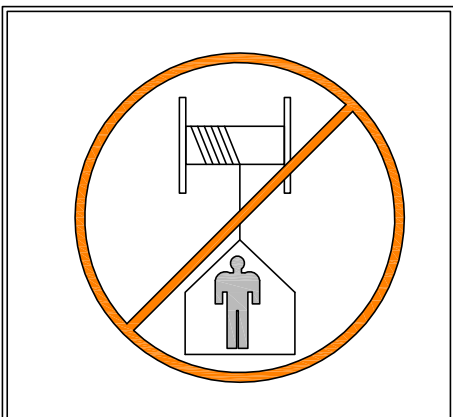

WARNING

- Winches are not to be used to lift, support, or otherwise transport personnel



VENCO VENTURO INDUSTRIES LLC
CINCINNATI, OHIO

TITLE
WINCH SAFETY
HT CRANES

DATE
02-21-14D
SUPERSEDES
04-04-12C

SECTION
C150
19217

PART NO.: 15398
 DECAL: UNPLUG REMOTE CONTROL
 FUNCTION: To inform the operator to unplug remote control when not being used.
 QUANTITY: 1
 PLACEMENT: Right side of housing.



PART NO.: 15401
 DECAL: UNLAWFUL TO OPERATE
 FUNCTION: To inform the operator of proper operation in vicinity of power lines.
 QUANTITY: 1
 PLACEMENT: Right side of housing.

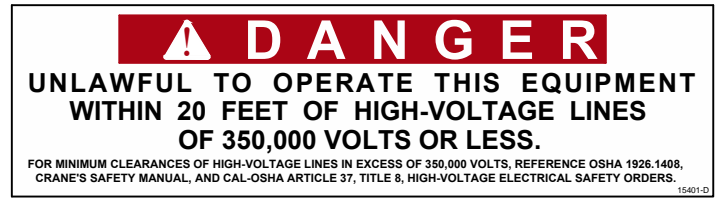

PART NO.: 19314-1 [LEFT] & -2 [RIGHT]
 DECAL: MANUAL OVERRIDE (NON-PROP)
 FUNCTION: To inform the operator of manual override locations.
 QUANTITY: 1 EACH
 PLACEMENT: Inside of rear cover.

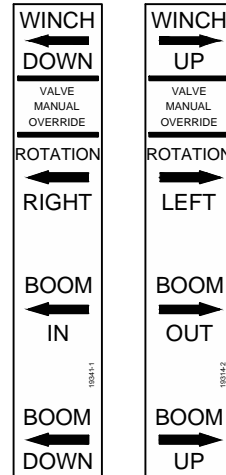

PART NO.: 22768-1 [LEFT] & -2 [RIGHT]
 DECAL: MANUAL OVERRIDE (PROPORTIONAL)
 FUNCTION: To inform the operator of manual override locations.
 QUANTITY: 1
 PLACEMENT: Inside of rear cover.

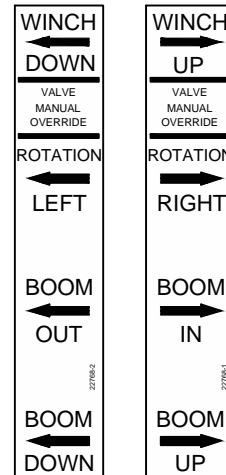

VENCO VENTURO INDUSTRIES LLC
 CINCINNATI, OHIO

TITLE	DATE	SECTION
DECAL DRAWING & LIST	11-30-22E	C150
HT40/50/60/66 SERIES	SUPERSEDES 02-21-14D	22181A

▲
 PART NO.: 23068-1 [LEFT] & -2 [RIGHT]
 DECAL: MANUAL OVERRIDE
 (HT66KXX w/ TH-2 Winch ONLY)
 FUNCTION: To inform the operator of
 manual override locations.
 QUANTITY: 1
 PLACEMENT: Inside of rear cover.

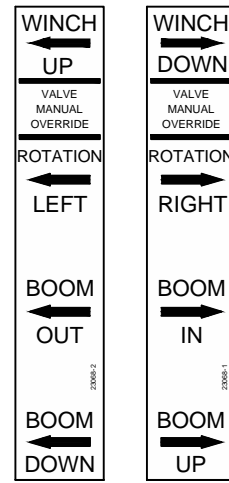

PART NO.: 19315-1
 DECAL: SHUT OFF (NON-PROPORTIONAL)
 FUNCTION: To show the operator how to
 override master shut off valve.
 QUANTITY: 1
 PLACEMENT: Inside rear cover.

WARNING!

KEEP VALVE IN NORMAL POSITION.
 OVERRIDE POSITION IS INTENDED
 FOR EMERGENCY USE ONLY.

NON-PROPORTIONAL VALVE
 PUSH IN STEM
 AND ROTATE

19315-1 Rev B

PART NO.: 19315-2
 DECAL: MANUAL OVERRIDE (PROPORTIONAL)
 FUNCTION: To show the operator how to
 override proportional valve.
 QUANTITY: 1
 PLACEMENT: Inside rear cover.

WARNING!

KEEP VALVE IN NORMAL POSITION.
 OVERRIDE POSITION IS INTENDED
 FOR EMERGENCY USE ONLY.

PROPORTIONAL VALVE
 ROTATE STEM

19315-2 Rev B

PART NO.: 20834
 DECAL: MANUAL OVERRIDE NOTICE
 FUNCTION: To inform the operator of
 manual override locations.
 QUANTITY: 1
 PLACEMENT: Inside rear cover.

NOTICE

FOR MANUAL OVERRIDE
 OF CRANE FUNCTIONS,
 REMOVE REAR COVER
 AND SEE INSTRUCTIONS
 INSIDE.

20834-B

PART NO.: 15390

DECAL: CAUTION - INSPECT VEHICLE & CRANE

FUNCTION: To inform the operator of key operating requirements.

QUANTITY: 1

PLACEMENT: Left side of rear cover.



PART NO.: 15391

DECAL: DANGER - NOT PASSENGER LIFT

FUNCTION: To inform the operator not to lift, support or transport personnel, and to ensure that crane operator is adequately trained.

QUANTITY: 1

PLACEMENT: Left side of rear cover.

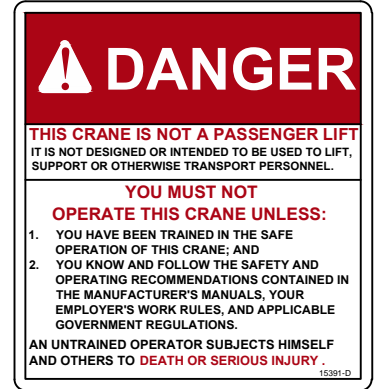

PART NO.: 15392

DECAL: DANGER - ELECTROCUTION HAZARD

FUNCTION: To inform the operator that the machine (crane) represents an electrocution hazard should it come too near or in contact with electrical voltage source.

QUANTITY: 1

PLACEMENT: Left side of rear cover.

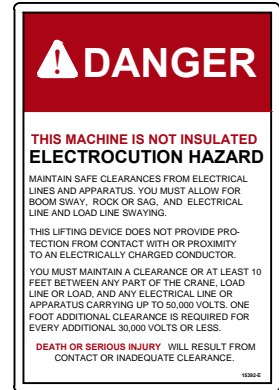

PART NO.: 22499

DECAL: KNOW YOUR SIGNALS

FUNCTION: To inform the operator of proper signals.

QUANTITY: 1

PLACEMENT: Right side of rear cover.

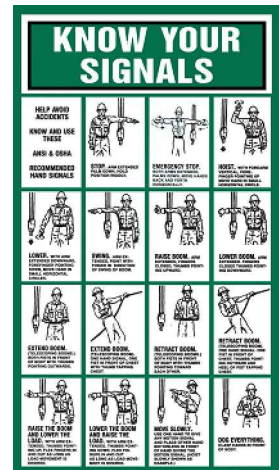

VENCO VENTURO INDUSTRIES LLC
CINCINNATI, OHIO

TITLE
DECAL DRAWING & LIST

HT40/50/60/66 SERIES

DATE
11-30-22F

SUPERSEDES
02-21-14E

SECTION
C150

22181C

PART NO.: 17389
 DECAL: MEDIUM VENTURO
 FUNCTION: Branding.
 QUANTITY: 1
 PLACEMENT: Rear cover.



PART NO.: 28525
 DECAL: MODEL HT45KX
 FUNCTION: Branding.
 QUANTITY: 2
 PLACEMENT: Boom.



PART NO.: 20927
 DECAL: CRANE STABILITY
 FUNCTION: To inform the operator of the crane's lifting capacity throughout the entire rotation.
 QUANTITY: 1
 PLACEMENT: In prominent location, so it is easily seen and readily identifiable.

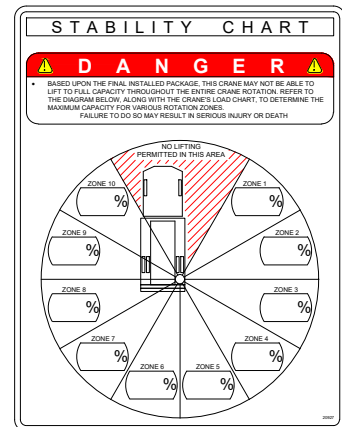

VENCO VENTURO INDUSTRIES LLC
 CINCINNATI, OHIO

TITLE
DECAL DRAWING & LIST
 HT45KX

DATE
 06-19-23
 SUPERSEDES
 -

SECTION
 C150
28526

LEFT SIDE OF BOOM

RIGHT SIDE OF BOOM

PART NO.: 24171 & 24172
 DECAL: HT45-30' CRANE CAPACITY (VLC)
 FUNCTION: To show the operator the operating capacities of the crane
 QUANTITY: 1 each
 PLACEMENT: Right side of boom, Left side of boom

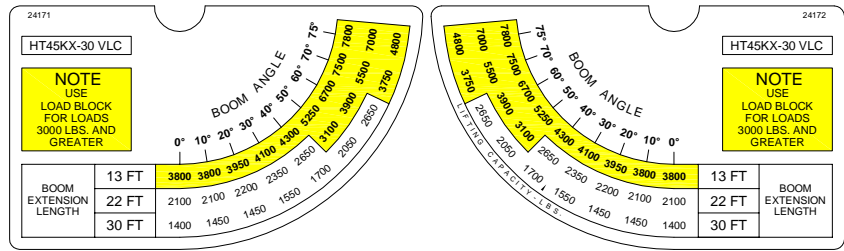

24171

24172

LEFT SIDE OF BOOM

RIGHT SIDE OF BOOM

PART NO.: 23464 & 23465
 DECAL: HT45-25' CRANE CAPACITY (VLC)
 FUNCTION: To show the operator the operating capacities of the crane
 QUANTITY: 1 each
 PLACEMENT: Right side of boom, Left side of boom

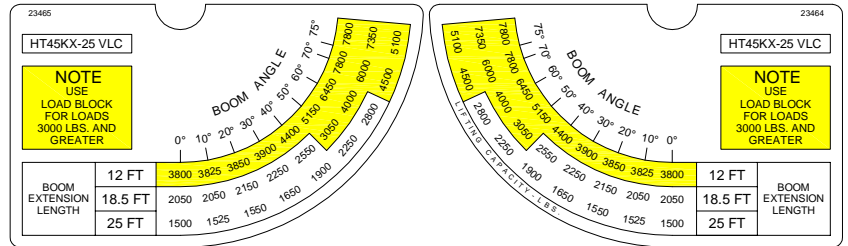

23465

23464

LEFT SIDE OF BOOM

RIGHT SIDE OF BOOM

PART NO.: 23462 & 23463
 DECAL: HT45-20' CRANE CAPACITY (VLC)
 FUNCTION: To show the operator the operating capacities of the crane
 QUANTITY: 1 each
 PLACEMENT: Right side of boom, Left side of boom

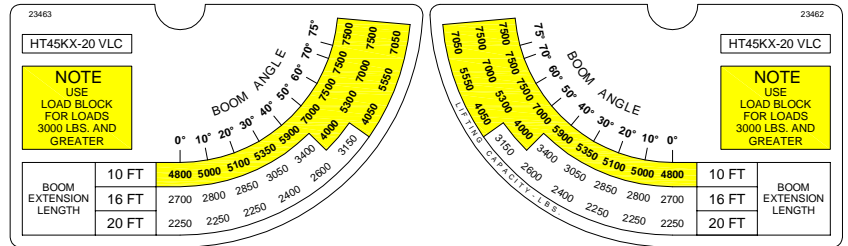

23463

23462

S P A C E I N T E N T I O N A L L Y L E F T B L A N K



VENCO VENTURO INDUSTRIES LLC
 CINCINNATI, OHIO

TITLE
BOOM CAPACITY DECALS
 HT45 SERIES

DATE
 06-29-21D
 SUPERSEDES
 05-28-20C

SECTION
 C150
23749

▲

PART NO.: 23742

DECAL: VLC, 2.94" x 6.00"

FUNCTION: To show that the crane is equipped with Venturo Logic Controls

QUANTITY: 2 each

PLACEMENT: Each side of Housing



▲

S P A C E I N T E N T I O N A L L Y L E F T B L A N K

S P A C E I N T E N T I O N A L L Y L E F T B L A N K

S P A C E I N T E N T I O N A L L Y L E F T B L A N K



VENCO VENTURO INDUSTRIES LLC
CINCINNATI, OHIO

TITLE

VLC DECALS

DATE

02-06-19A

SECTION

C150

VLC SERIES CRANES

SUPERSEDES

10-11-18

23748

SECTION 200

INSTALLATION



VENCO VENTURO INDUSTRIES LLC
CINCINNATI, OHIO

BODY REINFORCEMENT

The truck body must be reinforced and outriggers provided to withstand the combined loads resulting from lifting and the weight of the crane and boom.

The maximum combined overturning moment for the HT45KX is 45,000 ft. lbs.

The maximum vertical loads for the HT45KX are listed based on the boom length:

HT45KX VLC			
BOOM LENGTH (FT)	20'	25'	30'
MAX VERTICAL LOAD (LBS)	9400	9850	10050

CRANE MOUNTING

The crane base plate or mounting pedestal must be bolted to the body reinforcing plate with four [4] grade eight (8) bolts of 1" dia. with coarse threads, torqued to 680 foot pounds.
A 6" dia. hose clearance hole must be cut in this plate to allow the hoses to swing and coil freely.

ROTATION POSITIONING

The HT cranes are shipped with the boom rotated as shown on drawing 20051. It can be in any position that pleases the user since the boom can always reach the storage and travel position by rotating one way or the other.

HYDRAULIC CONNECTIONS

The crane is furnished with a pressure, return and a case drain hoses that come down through the center of the housing. The pressure and return hoses connect to two hydraulic swivels to prevent damage while rotating the crane right and left.

CAUTION

- THE CASE DRAIN HOSE MUST BE A DEDICATED RETURN HOSE UNRESTRICTED TO TANK / RESERVOIR. DO NOT 'T' INTO ANOTHER EXISTING RETURN HOSE OR DAMAGE TO THE HYD. WINCH FROM BACK-PRESSURE WILL OCCUR. BACK-PRESSURE IN EXCESS OF 200 PSI WILL DAMAGE THE HYD. WINCH.

Arrange the pressure & return hoses in the compartment below the crane so that they are connected in a relaxed position while the crane is at the midpoint of the 400 degree rotation range -- regardless of the final position of the boom during storage/travel. See installation pages 22913 for more information on hose connections.



VENCO VENTURO INDUSTRIES LLC
CINCINNATI, OHIO

TITLE
CRANE INSTALLATION
HT45KX VLC SERIES

DATE
05-23-23
SUPERSEDES
-

SECTION
C200
26900

CRANE INSTALLATION, PAGE 2

HT45/55 VLC SERIES CRANES

▲ ELECTRICAL CONNECTIONS

An electrical power lead - intended for 12V DC only - comes down through the center of the crane base plate along with the hoses. This power lead should be slacked in the compartment so that it remains relaxed throughout the 400 degree rotation of the crane.

A 20 amp circuit breaker is mounted on the crane and protects the crane's internal wiring and solenoid coils. The 20 amp circuit breaker does NOT protect the electrical power lead. For added protection, the electrical power lead can be connected to a 20 amp protected circuit that, if possible, is powered only when the vehicle engine is running.

HYDRAULIC FLUID

<u>Average Climate</u>	<u>Type of Oil</u>
Cold to Moderate	ISO Grade AW 46
Warm to Hot	ISO Grade AW 68

The fluid should have the highest anti-wear characteristics and treated to inhibit rust and oxidation.

HYDRAULIC HOSES & LINES

The minimum sizes for lines and hoses are as follows:

HYDRAULIC LINES	HT45/55 SERIES
PRESSURE	5/8"
RETURN	3/4"
SUCTION	1-1/4"

RESERVOIR

The PTO reservoir should have a capacity of 25 gallons fitted with 100 mesh suction screen, 10 micron return line filter, and filler/breather cap.

▲ PTO PUMP

The PTO and pump should be sized to deliver approximately 12.0 GPM at 3000 psi for the HT45/55 VLC series cranes.

PTO START-UP

Before connecting the PTO system to the crane pressure and return hoses, connect the PTO pressure and return lines together at the bulkhead. Operate the PTO system for about two (2) minutes per gallon of reservoir capacity (25 gallon reservoir = 50 minutes) to flush out the lines and filter all the fluid several times.

ENGINE START/STOP & THROTTLE CONTROL

If your crane was purchased with optional engine start/stop and throttle control, refer to drawing 22615 in the replacement parts section for further information.



VENCO VENTURO INDUSTRIES LLC
CINCINNATI, OHIO

TITLE
CRANE INSTALLATION
HT45/55 VLC SERIES

DATE
08-08-23C
SUPERSEDES
05-10-21B

SECTION
C200

23752

400° ROTATION STOP LOCATION

CURBSIDE

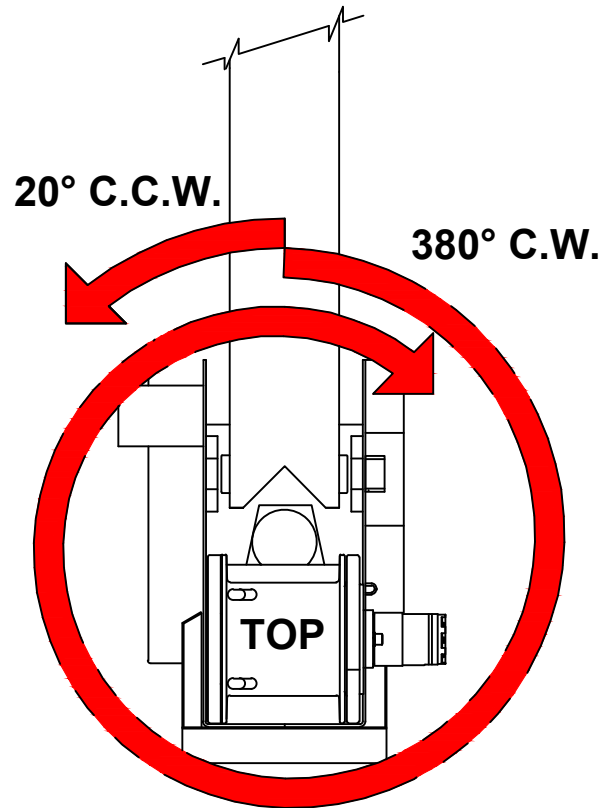

STREETSIDE

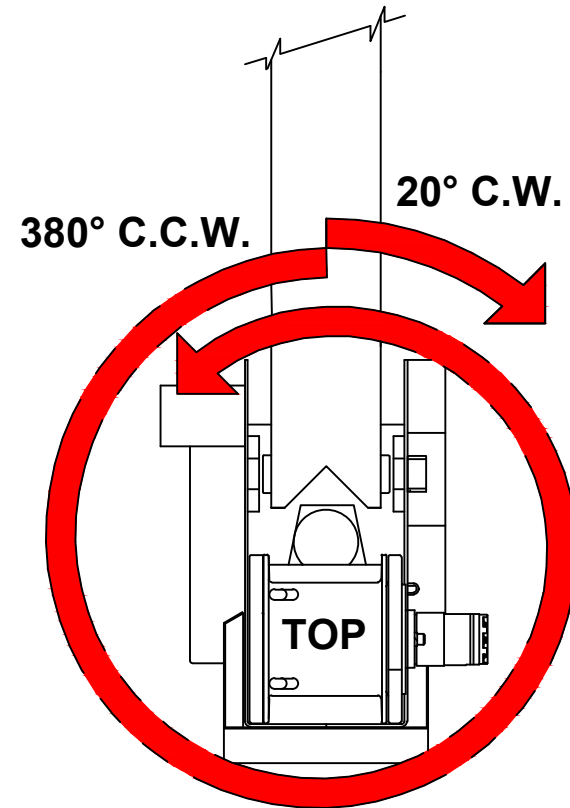

VENCO VENTURO INDUSTRIES LLC
CINCINNATI, OHIO

TITLE
ROTATION STOP LOCATION

400° ROTATION CRANES

DATE
03-09-23F

SUPERSEDES
05-20-20E

SECTION
C200

20051

STABILITY TEST - HT45-25'-VLC SERIES

Overview

Venturo follows the guidelines of ANSI B30.5 in defining stability. Generally speaking, a truck is considered stable as long as it is not on the verge of tipping - i.e. with the truck level, **at least one tire** on each corner of the truck must remain in contact with the ground.

It is important to note that nearly every installation is unique and will, therefore, typically require stability testing.

The procedure outlined below follows ANSI's (B30.5 - 5-1.1.1) specified "maximum load rating" of 85% of truck stability.

Testing Procedure

1. Locate the truck on firm, level ground and set parking brake.
2. Fully deploy stabilizers, making sure they are firmly in contact with supportive ground; use stabilizer pads as required. The tires of the truck should remain in full contact with the ground.
3. Inspect wire rope and other key components of crane (consult owners manual for more information).
4. Conduct an operational check of all crane functions.
5. Use a **Test Weight** weighing a **minimum** of **1765 lbs.**, (includes load block weight of **51 lbs.**) to a **maximum of 2000 lbs.**
6. Place the VLC system into **Stability Mode** (ref. VLC Manual, INST-30000, page 30005)
7. Position the boom level and fully **retracted**
8. Referring to the Stability Chart (drawing 20907) rotate the crane to a position between 1 and 2 o'clock (truck cab is facing 12 o'clock) to begin testing.
9. Use the winch to lift the Test Weight; DO NOT allow the weight to be more than 6" off the ground at any time during testing (for safety).
10. Using a test weight weighing between **1765 to 2000 lbs.**, extend the boom slowly, until one of three conditions occur:
 - 10.1. Full extension is reached - Mark the **ZONE** in question **100%**
 - 10.2. The VLC system stops the boom extension - Mark the **ZONE** in question **100%**
 - 10.3. The truck becomes unstable i.e. a tire lifts off the ground
 - 10.3.1. Retract the boom until at least one tire on each corner of the truck is making contact with the ground
 - 10.3.2. Use the formula below to determine the allowable **% Rated Capacity** for the **ZONE** in question:
11. Note: The "**Max Stable Reach in inches**" is measured from the **center of rotation** of the crane housing to the **lifting load hook**.

$$\% \text{ Rated Capacity} = \frac{\text{"Max Stable Reach" in inches}}{302} \times 100$$

12. Record the **% of Rated Capacity** in the appropriate blank (region) on the Crane Stability page (ref. 20907) and decal.

13. Repeat Steps 7 through 12 for each **ZONE** on the stability page.



VENCO VENTURO INDUSTRIES LLC
CINCINNATI, OHIO

TITLE	DATE	SECTION
STABILITY TEST	07-29-21D	C200
HT45-25'-VLC SERIES	SUPERSEDES	20906-45
	02-16-21C	

CRANE STABILITY

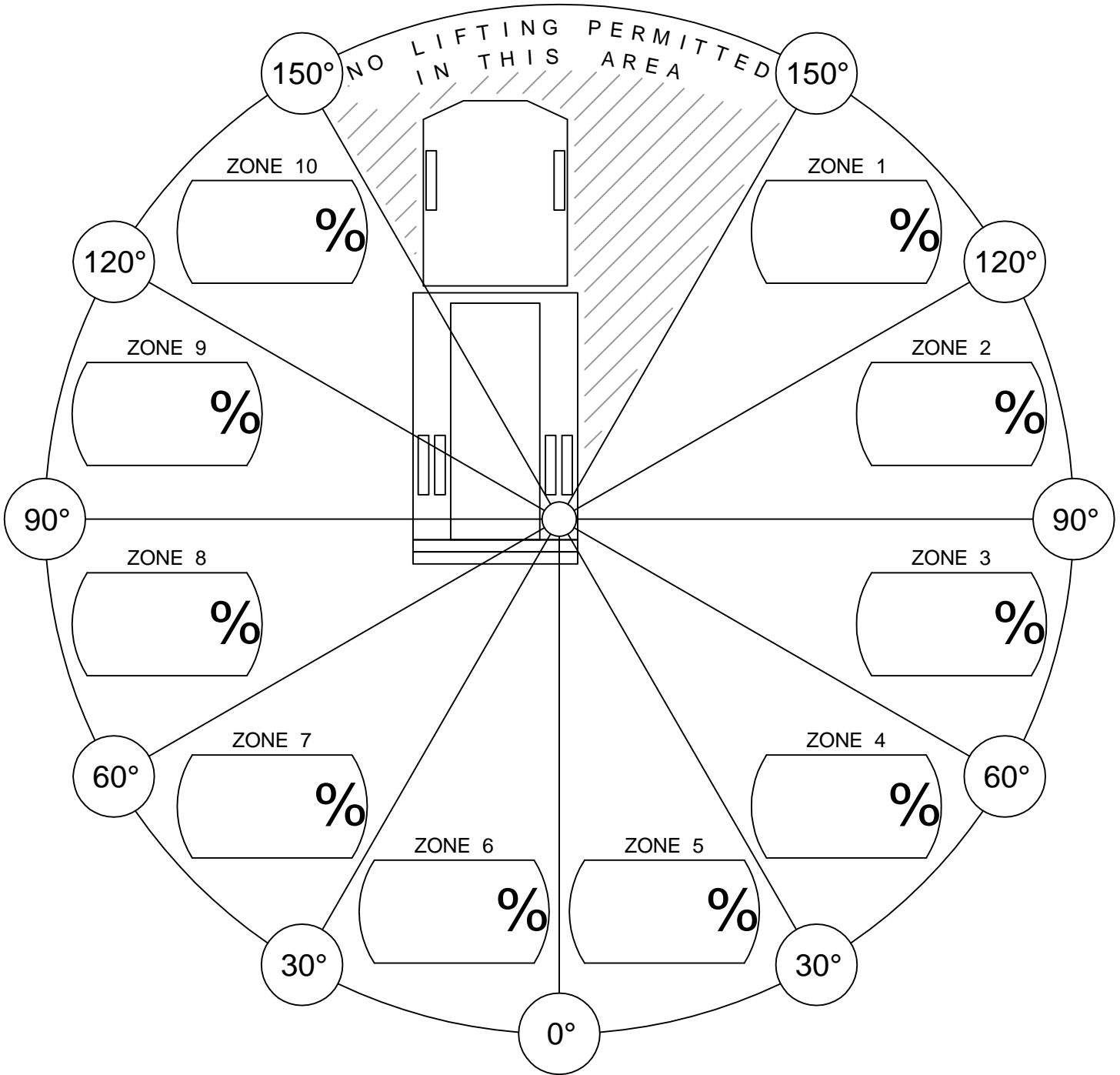

% of Rated Capacity for each of the 10 regions are provided above.

CONDITIONS:

- STABILIZERS FULLY EXTENDED & DOWN, ON FIRM LEVEL GROUND.



VENCO VENTURO INDUSTRIES LLC
CINCINNATI, OHIO

TITLE
STABILITY CHART

VENTURO CRANES

DATE
05-11-17F

SUPERSEDES
02-21-14E

SECTION
C200

20907

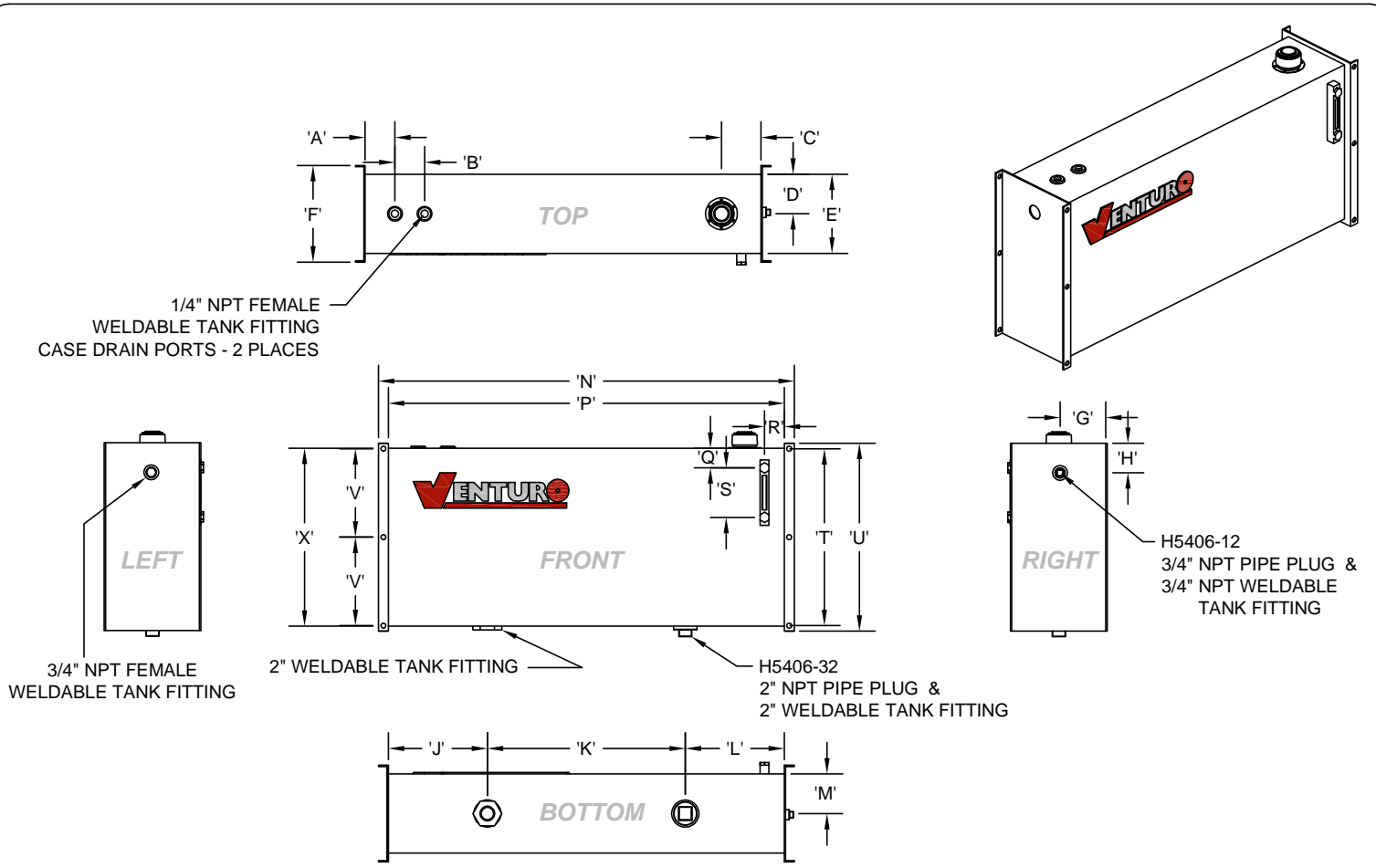

ILLUSTRATIONS FOR REFERENCE ONLY!
- COMPONENT LOCATIONS MAY DIFFER -

HYD. TANK DIMENSION (HTD) CHART			
DIMENSION	PART NO.	22786 (25 GAL.)	22999 (40 GAL.)
'A'		3"	3"
'B'		3"	3"
'C'		4"	4"
'D'		4"	5.5"
'E'		8"	11"
'J'		5"	6"
'K'		30"	30"
'L'		5"	6"
'M'		4"	5.5"
'P'		40"	42"
'Q'		2"	2"
'R'		2"	2"
'S'		5"	5"
'X'		18"	20"

MEASUREMENTS EXCLUDE MOUNTING APARATUSES

MOUNTING DIMENSION (TMD) CHART			
DIMENSION	PART NO.	22786 (25 GAL.)	22999 (40 GAL.)
'F'		9.75"	12"
'G'		4.875"	6"
'H'		3"	3"
'N'		42"	44"
'T'		17.875"	19.875"
'U'		19"	21"
'V'		8.938"	9.938"

MEASUREMENTS INCLUDE MOUNTING APARATUSES



VENCO VENTURO INDUSTRIES LLC
CINCINNATI, OHIO

TITLE	DATE	SECTION
RESERVOIR DIMENSIONS	02-21-14E	C200
HYD. TANKS (25/40 GAL.)	SUPERSEDES 06-04-13D	22825

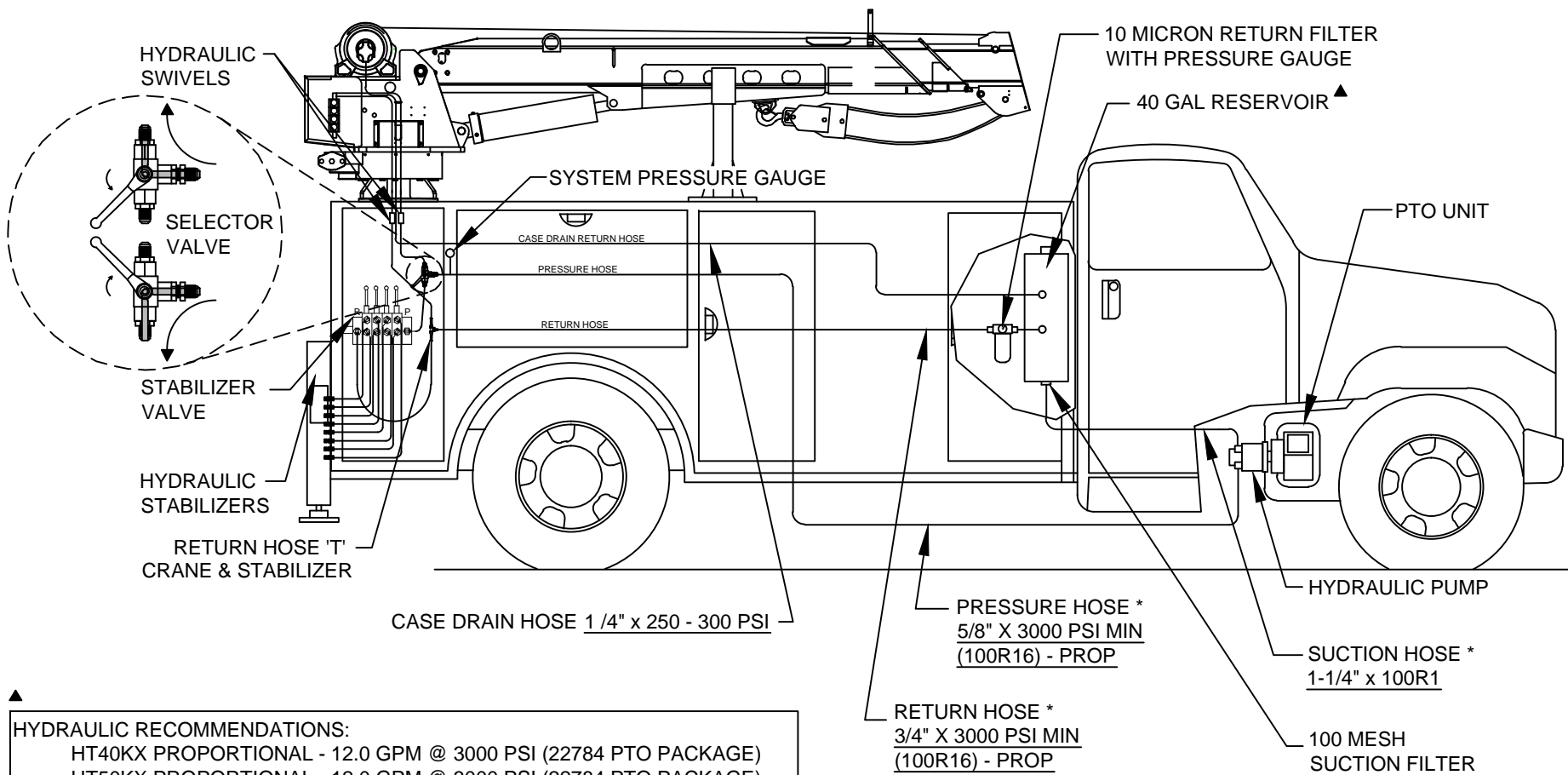

HYDRAULIC RECOMMENDATIONS:

- HT40KX PROPORTIONAL - 12.0 GPM @ 3000 PSI (22784 PTO PACKAGE)
- HT50KX PROPORTIONAL - 12.0 GPM @ 3000 PSI (22784 PTO PACKAGE)
- HT45KX - 12.0 GPM @ 3000 PSI (22998 PTO PACKAGE)
- HT55KX - 12.0 GPM @ 3000 PSI (22998 PTO PACKAGE)
- HT60KX - 12.0 GPM @ 3000 PSI (22998 PTO PACKAGE)
- HT66KX - 12.0 GPM @ 3000 PSI (22998 PTO PACKAGE)

CAUTION

- SELECTOR VALVE MUST BE 'NON-CLOSED CENTER TRANSITION' TYPE.

REFER TO SECTION 200 FOR MORE INFORMATION ON INSTALLING HYDRAULIC COMPONENTS.

* HOSES AND FITTINGS BETWEEN PUMP, RESERVOIR, AND CRANE *NOT INCLUDED*.

CAUTION

- THE CASE DRAIN LINE FROM THE WINCH MUST HAVE AN UNRESTRICTED PATH TO TANK/RESERVOIR.



VENCO VENTURO INDUSTRIES LLC
CINCINNATI, OHIO

TITLE	DATE	SECTION
HYDRAULIC COMPONENT INSTALLATION	07-15-24H	C200
HT40-66, PROPORTIONAL	SUPERSEDES 08-08-23G	22883

HYDRAULIC CIRCUIT CONNECTION GUIDE - SINGLE PUMP (NO COMPRESSOR)
 (REFER TO SECTION 200 FOR MORE INFORMATION, INCLUDING HOSE SPECIFICATIONS)

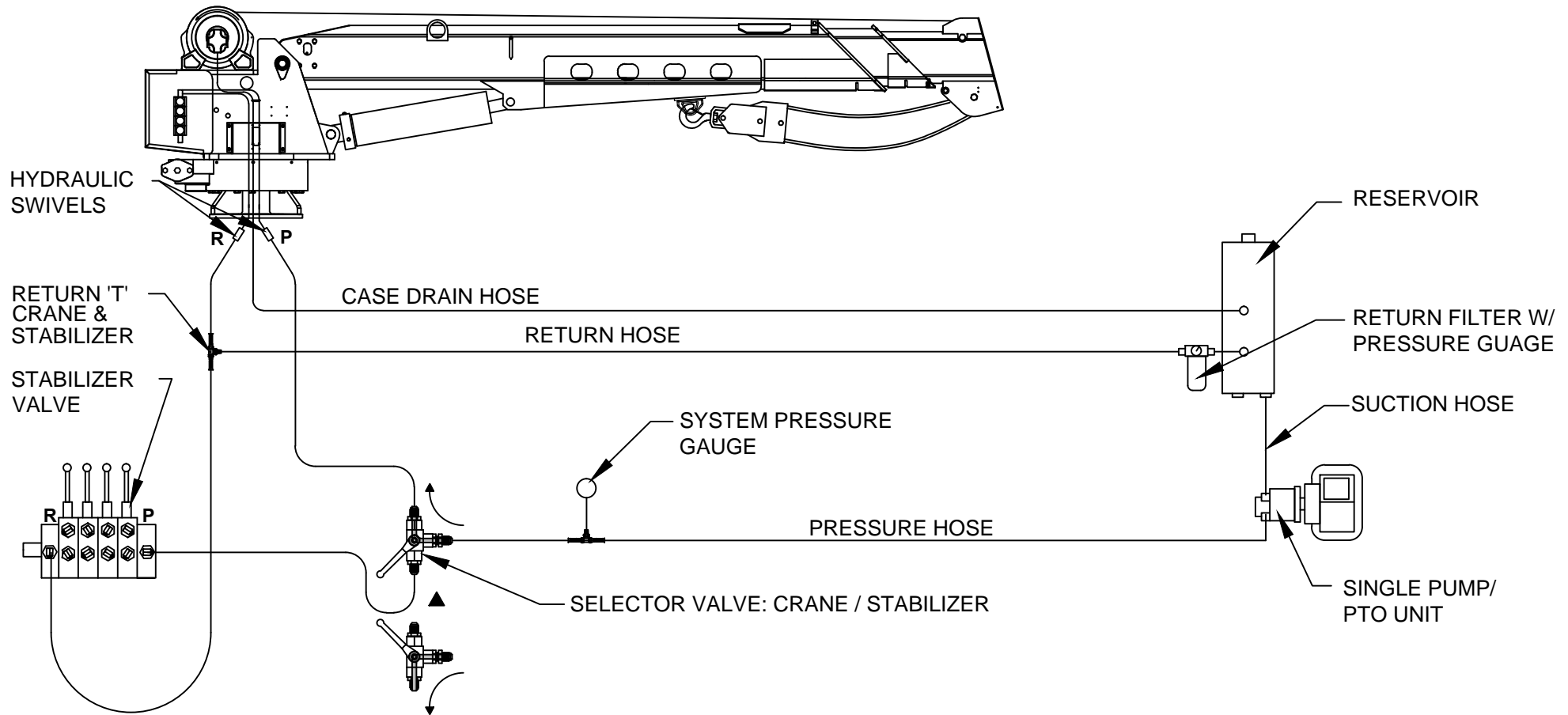

CAUTION

- SELECTOR VALVE MUST BE 'NON-CLOSED CENTER TRANSITION' TYPE.

CAUTION

- THE CASE DRAIN LINE FROM THE WINCH MUST HAVE AN UNRESTRICTED PATH TO TANK/ RESERVOIR.



VENCO VENTURO INDUSTRIES LLC
CINCINNATI, OHIO

TITLE
CONNECTION GUIDE, PAGE 1 / 2

HT CRANES

DATE
08-09-23C

SUPERSEDES
02-21-14B

SECTION
C200

23015

HYDRAULIC CIRCUIT CONNECTION GUIDE - SINGLE PUMP W/ COMPRESSOR

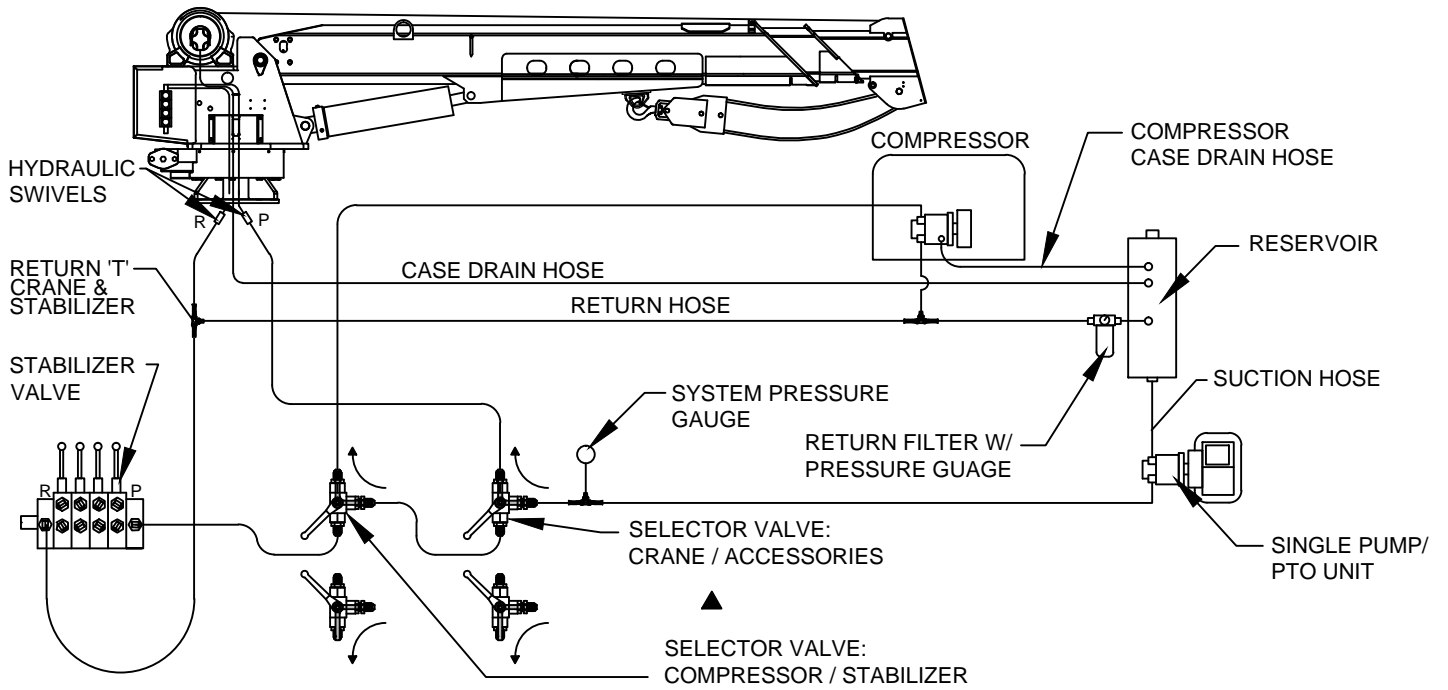

HYDRAULIC CIRCUIT CONNECTION GUIDE - TWO-STAGE PUMP W/ COMPRESSOR

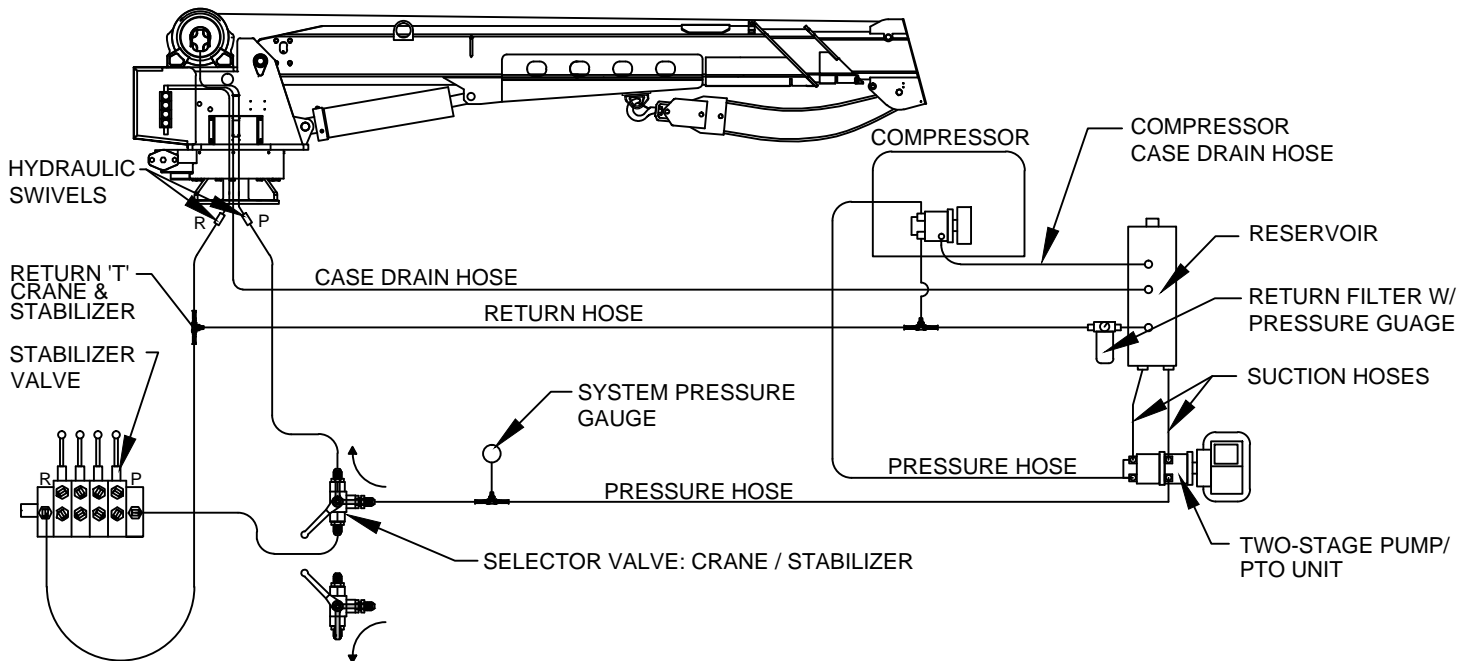

CAUTION

- SELECTOR VALVE MUST BE 'NON-CLOSED CENTER TRANSITION' TYPE.

REFER TO SECTION 200 FOR MORE INFORMATION, INCLUDING HOSE SPECIFICATIONS



CAUTION

- THE CASE DRAIN LINE FROM THE WINCH MUST HAVE AN UNRESTRICTED PATH TO TANK/ RESERVOIR.



VENCO VENTURO INDUSTRIES LLC
CINCINNATI, OHIO

TITLE
CNNCTN GDE, PAGE 2/2

HT CRANES

DATE
08-08-23C

SUPERSEDES
02-21-14B

SECTION
C200

23014

RECOMMENDED SUPPLY & RETURN HOSE CONNECTIONS CRANE & STABILIZERS

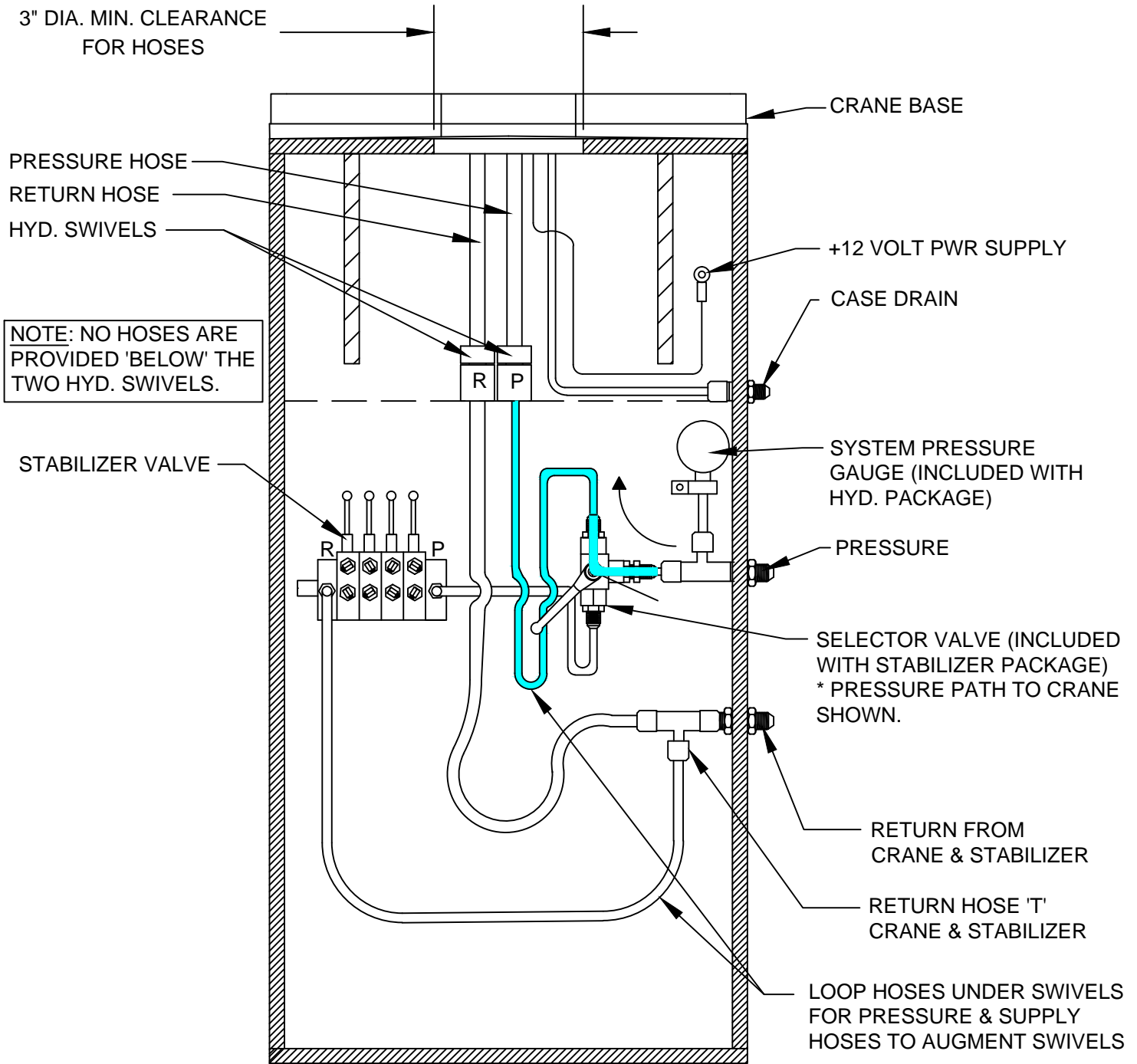

CAUTION

- SELECTOR VALVE MUST BE 'NON-CLOSED CENTER TRANSITION' TYPE VALVE.



CAUTION

- CASE DRAIN MUST RETURN DIRECTLY TO RESERVOIR WITHOUT RESTRICTION.



VENCO VENTURO INDUSTRIES LLC
CINCINNATI, OHIO

TITLE
CONNECTIONS GUIDE

HT CRANES

DATE
08-07-23G

SUPERSEDES
02-21-14F

SECTION
C200

22913

WIRE ROPE INSTALLATION

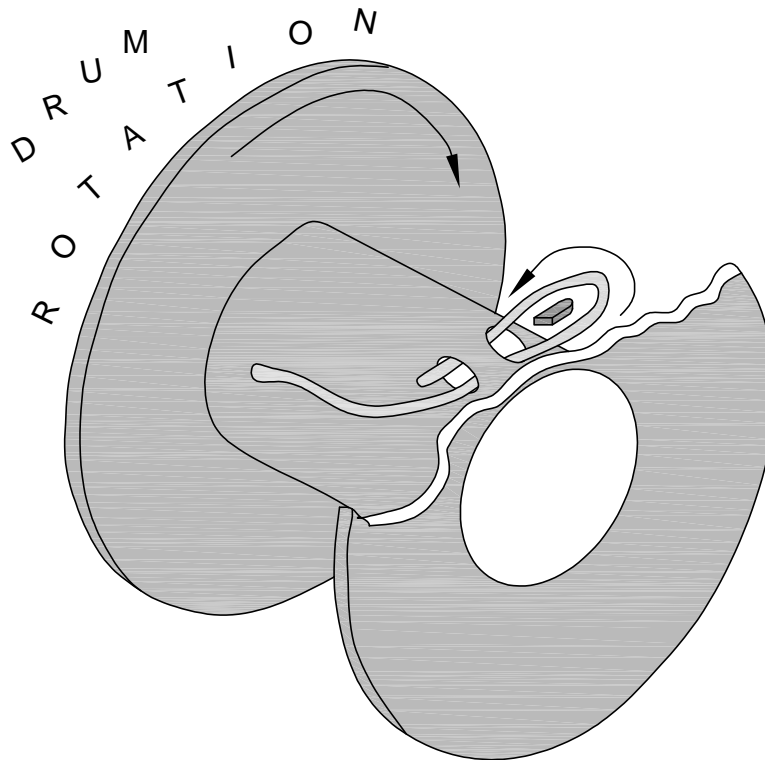

FIG. 1

- STEP 1: UNWIND COIL OF WIRE ROPE BY 'ROLLING' ALONG THE FLOOR. THIS WILL PREVENT 'KINKING'.
- STEP 2: INSERT WIRE ROPE END UP THROUGH ANTI-2-BLOCK (A2B) CAGE ASSEMBLY, BETWEEN CHEEK PLATES, OVER THE TOP SHEAVE, AND THROUGH WIRE ROPE GUIDE.
- STEP 3: INSERT WIRE ROPE END INTO POCKET OPENING ON WINCH, WRAP AROUND WEDGE, AND BACK THROUGH POCKET OPENING AS SHOWN IN FIGURE 1.



CAUTION

- IF THE WIRE ROPE IS NOT INSTALLED FOR THE CORRECT DRUM ROTATION, THE WINCH BRAKE VALVE WILL NOT HOLD THE LOAD.



CAUTION

- THERE MUST ALWAYS BE AT LEAST [5] DEAD WRAPS OF WIRE ROPE ON THE WINCH DRUM WHILE UNDER LOAD.

NOTE: SOME WINCHES MAY BE SUPPLIED WITH A HEX NUT IN LIEU OF A WEDGE FOR INSTALLING THE WIRE ROPE.



VENCO VENTURO INDUSTRIES LLC
CINCINNATI, OHIO

TITLE

WIRE ROPE INSTALLTN

DATE

02-21-14K

SECTION

C200

ET6K & LARGER CRANES

SUPERSEDES

12-26-13J

22245

SECTION 300

OPERATION

&

MAINTENANCE



VENCO VENTURO INDUSTRIES LLC
CINCINNATI, OHIO

MAINTENANCE OVERVIEW INFORMATION

MAINTENANCE

The crane requires only periodic lubrication. As a standard procedure, this can be done at the time the vehicle is serviced.

GENERAL

Inspect wire rope for any evidence of kinks or fraying. Ensure that lifting hook of wire rope shows no evidence of damage and is functioning normally.

Inspect headache ball ("load block") for any signs of damage or excessive wear.

Service all grease fitting locations.

Inspect hydraulic hoses and hydraulic fittings for hydraulic leaks.

Inspect electrical connections for any looseness or corrosion.

Inspect bolts and verify all are tight, paying particular attention to winch, rotation system, and mounting base bolts.

Inspect all pins and snap rings for proper fit and function.

Inspect sheaves for excessive wear or play.

Perform a basic inspection of the winch with each use, monitoring for unusual noise or hydraulic leaks.



VENCO VENTURO INDUSTRIES LLC
CINCINNATI, OHIO

TITLE	DATE	SECTION
MAINTENANCE INFO	06-11-24E	C300
HT25/30/40/50/60/66KX(P)	SUPERSEDES 11-10-22D	23203

CRANE OPERATION AND MAINTENANCE INSTRUCTIONS ▲

SAFETY

Before operating this crane, read and understand these instructions, the 920612 Crane Safety and Hazards Information Sheet, and review all safety & instruction labels on the crane.

CRANE INSPECTION

Before operating this crane, inspect for wear, damage, or oil leakage. After the wire rope has been run out, check for wear, kinks, and broken strands. Check the hook and safety latch for damage. Correct any problems before using the crane.

See Crane Safety Manual for proper inspection schedules and reports .

CAPACITY

Before operating this crane, review the capacity charts on the sides of the boom to relate the load to be lifted to the boom length and angle. The boom angle is shown by a gravity arrow.

LOAD BLOCK ▲

If the load exceeds the single-line rated load or if reduced winching speed for better control of smaller loads is required, use the load block to rig the crane for two part line operation.

CONTROLS ▲

The control pendant should be stored in a compartment or the cab when the crane is not in use.

Before activating the control pendant, inspect the cord(s) and pendant head/switches for damage. With the pendant OFF and the PTO disengaged, actuate all switches in both directions to verify that they all have the same feel/sound and return to the center position.

PTO SYSTEM ▲

Check the hydraulic fluid level in the PTO system reservoir. Engage PTO and set the engine speed to provide the desired hydraulic flow rate per the PTO system instructions.

CRANE OPERATION

Use "Winch Down" to release tension on the wire rope to unhook it from the storage tie down position.

Use "Boom Up" to elevate the boom from the boom rest position.

Avoid repeated rapid reversals of the control switches. This can cause the load to swing.

Check all control functions to see that they are working as described in the following section.



VENCO VENTURO INDUSTRIES LLC
CINCINNATI, OHIO

TITLE	DATE	SECTION
CRANE OP / MNTNC INST	08-08-23A	C200
HT CRANES ▲	SUPERSEDES 10-11-18	23753

CONTROL FUNCTIONS ▲

- WINCH "UP" and "DOWN" - Raises and lowers the load with the winch.
- BOOM "UP" and "DOWN" - Raises and lowers the boom elevation angle.
- BOOM "OUT" and "IN" - Extends and retracts the boom.
- ROTATION "L" and "R" - Controls the left and right direction of the crane rotation.
- TRIGGER - Varies the flow rate delivered to the crane valve. The farther the trigger is pulled, the faster the selected crane function operates.

VLC OVERLOAD SENSING SYSTEM

This crane is equipped with the Venturo Logic Control (VLC) overload sensing system. If the capacity of the crane is exceeded, the "Winch Up", "Boom Down", and "Boom Out" functions will be shut down. The "Winch Down", "Boom Up", and "Boom In" functions will continue to operate and can be used to relieve the overload condition. The "Rotation" function also will continue to operate.

TWO-BLOCK SENSING SYSTEM

This crane is equipped with an anti two-block device that is mounted at the tip of the boom. If the load block / overhaul weight contacts the device the "Winch Up", "Boom Down", and "Boom Out" functions are disabled. The "Winch Down", "Boom Up", and "Boom In" functions will continue to operate and can be used to relieve the two-block condition.



VENCO VENTURO INDUSTRIES LLC
CINCINNATI, OHIO

TITLE	DATE	SECTION
CRANE OP / MNTNC INST	06-26-24F	C200
HT VLC SERIES ▲	SUPERSEDES 06-07-24E	23754

TRUCK SETUP & STABILIZERS

1. The truck should be parked on firm level ground.
2. The center of the crane should be positioned close enough to the job so that it can be operated at a reach that puts the load within the rated capacity of the crane.
3. Set the vehicle parking brake and put the vehicle transmission in "park" if it is an automatic.
4. Fully deploy stabilizers to help stabilize vehicle against rocking or overturning.
5. Use stabilizers to level vehicle only. Tires must maintain contact with ground.

PREPARATION FOR TRAVEL

1. Return the stabilizers to the stowed position. Install and secure all pins.
2. Stow the crane boom in the boom support.
3. Hook the winch line to a tie down point on the body or pedestal and apply tension.
4. Disengage the PTO pump and idle speed control.
5. Power down the control pendant and store in a body compartment or the cab.
6. Turn OFF power to crane. ▲

MAINTENANCE

The crane requires only periodic lubrication. As a standard procedure, this can be done at the time the vehicle is serviced.

The winch planetary gearbox lube should be maintained at the level plug.

To ensure optimal winch performance, the following lube schedule and lube specifications should be followed:

Initial Change - after 6 months or 100 hours of operation (whichever comes first).

Periodic Change - every 24 months or 300 hours of operation (whichever comes first).

HLP 46 or HLP 68 hydraulic oil

Service grease fittings and rotation gear with molybdenum-disulfide graphite-filled lithium-based extreme pressure grease.

Grease fitting locations:

- Boom pivot at rear of boom
- Slew drive (2 or 3 zerk fittings depending on component supplier)
- Swing bearing race (2 zerk fittings)
- Elevation cylinder base and rod pivots

Remove rear cover and check all hydraulic tube and hose fittings for tightness.

Check electrical connections for looseness and corrosion.



VENCO VENTURO INDUSTRIES LLC
CINCINNATI, OHIO

TITLE	DATE	SECTION
CRANE OP / MNTNC INST	06-18-24B	C200
HT40/45/50	SUPERSEDES 06-12-24A	23755

EXPLANATION OF HYDRAULIC VALVE SYSTEM HT40/50/60/66KX, PROPORTIONAL ONLY

OVERVIEW

This proportional crane utilizes a proportional valve, which controls the rate at which the hydraulic fluid flows through the valve bank. When the proportional valve is fully closed, hydraulic fluid bypasses the valve bank and returns directly to the tank. When the proportional valve is fully open, hydraulic fluid cycles through the valve bank and allows the crane to function at full speed. When the proportional valve is at any setting between, a portion of the fluid is allowed through the valve bank, with the remainder returning to the tank.

The four [4] crane functions (winch, rotation, boom extension, and boom elevation) are controlled by four [4] separate valve sections. Each valve section has two [2] solenoid coils (and two [2] manual overrides) which control the direction that the function operates (e.g. winch up vs. winch down). For a given crane function and direction (e.g. winch up), the solenoid coil and associated manual override reside on the same side of the valve bank.

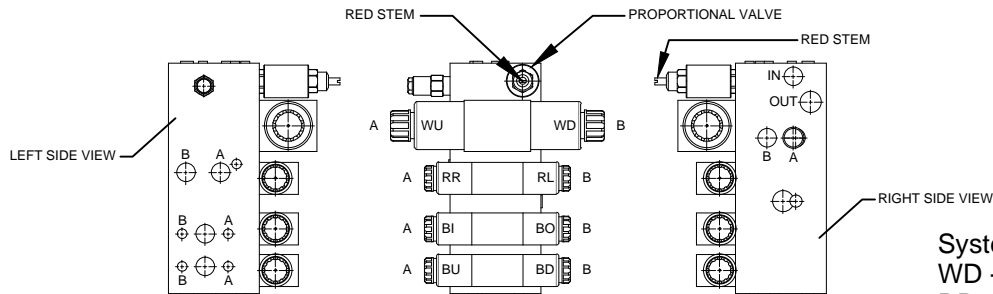

System abbreviations are as follows:
 WD - Winch Down WU - Winch Up
 RR - Rotation Right RL - Rotation Left
 BI - Boom In (Ext.) BO - Boom Out (Ext.)
 BD - Boom Down (Elev.) BU - Boom Up (Elev.)

MANUAL OVERRIDE SYSTEM

Should an electrical failure occur, your Venturo crane can be operated manually. The manual overrides are intended for emergency use only and should not be used for normal operation.

To operate in manual override mode:

- (1) Override the proportional valve by turning the red stem on the valve as stated below
 - For override operation, rotate stem clockwise (the farther the stem is turned the faster the crane will operate)
 - To return to normal operation, rotate the stem counter-clockwise until it stops
- (2) Determine the coil / override associated with the function you wish to operate, then insert a small diameter object (an Allen wrench works well) into the detent on the end of the valve stem and firmly press inward. For example, pushing the stem labeled 'A' on the first bank (refer to illustration) will actuate winch up



W A R N I N G



- For normal crane operation, the proportional valve must be in the 'normal' position (as described above). To verify 'normal' operation, you may set the pendant (or radio) control aside and actuate a single crane function by pushing inward on any of the manual override pins, located at the ends of each function control valve. If that function operates, the proportional valve is still in manual override. Check the position of the proportional valve's red stem to insure that it is fully counter-clockwise.

EMERGENCY STOP

In the unlikely event that a function of the crane does not stop once the function's toggle switch is released, the proportional crane can be stopped by releasing the trigger on activating the red E-STOP button on the transmitter.



VENCO VENTURO INDUSTRIES LLC
CINCINNATI, OHIO

TITLE
HYDRAULIC SYSTEM
HT40/50/60/66KX; PROP

DATE
11-10-22E
SUPERSEDES
02-21-14D

SECTION
C200
22168

WIRE ROPE ASSEMBLY

WIRE ROPE:

▲ 3/8" DIA, 100' OR 125' LONG

GAC 7X19 XIP-RHRL-IWRC, SB 14,400 LBS

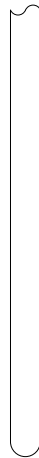

TERMINATES IN THIMBLE
NO HOOK

LOAD BLOCK ASSEMBLY

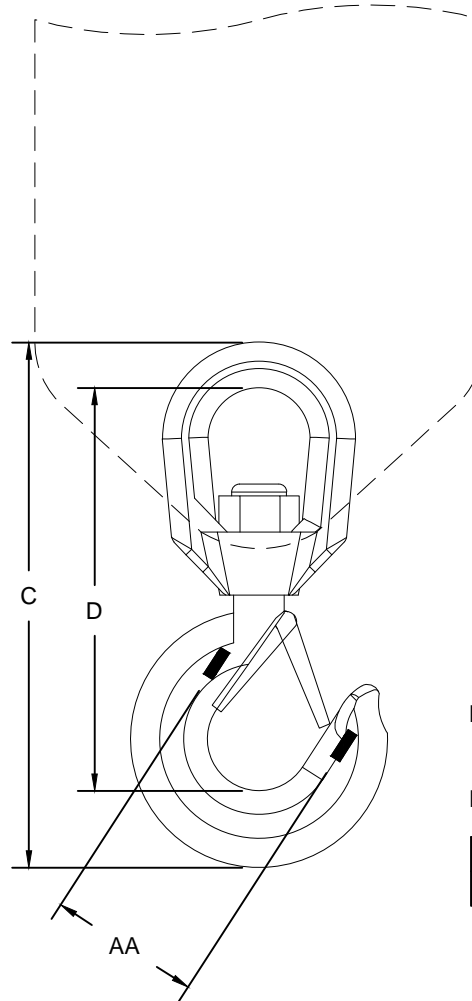

LOAD BLOCK HOOK:

RATING: 5 TONNE (11,023 LBS)

DIMENSIONS:

COLOR	BRAND	AA	C	D
GOLD	CROSBY	2.50"	9.69"	7.50"



VENCO VENTURO INDUSTRIES LLC
CINCINNATI, OHIO

TITLE

WIRE ROPE & HOOK SPECIFICATIONS

▲
HT40/45/50KX

DATE

08-15-24E

SUPERSEDES

05-09-16D

SECTION

C300

23231

SECTION 400

REPLACEMENT PARTS



VENCO VENTURO INDUSTRIES LLC
CINCINNATI, OHIO

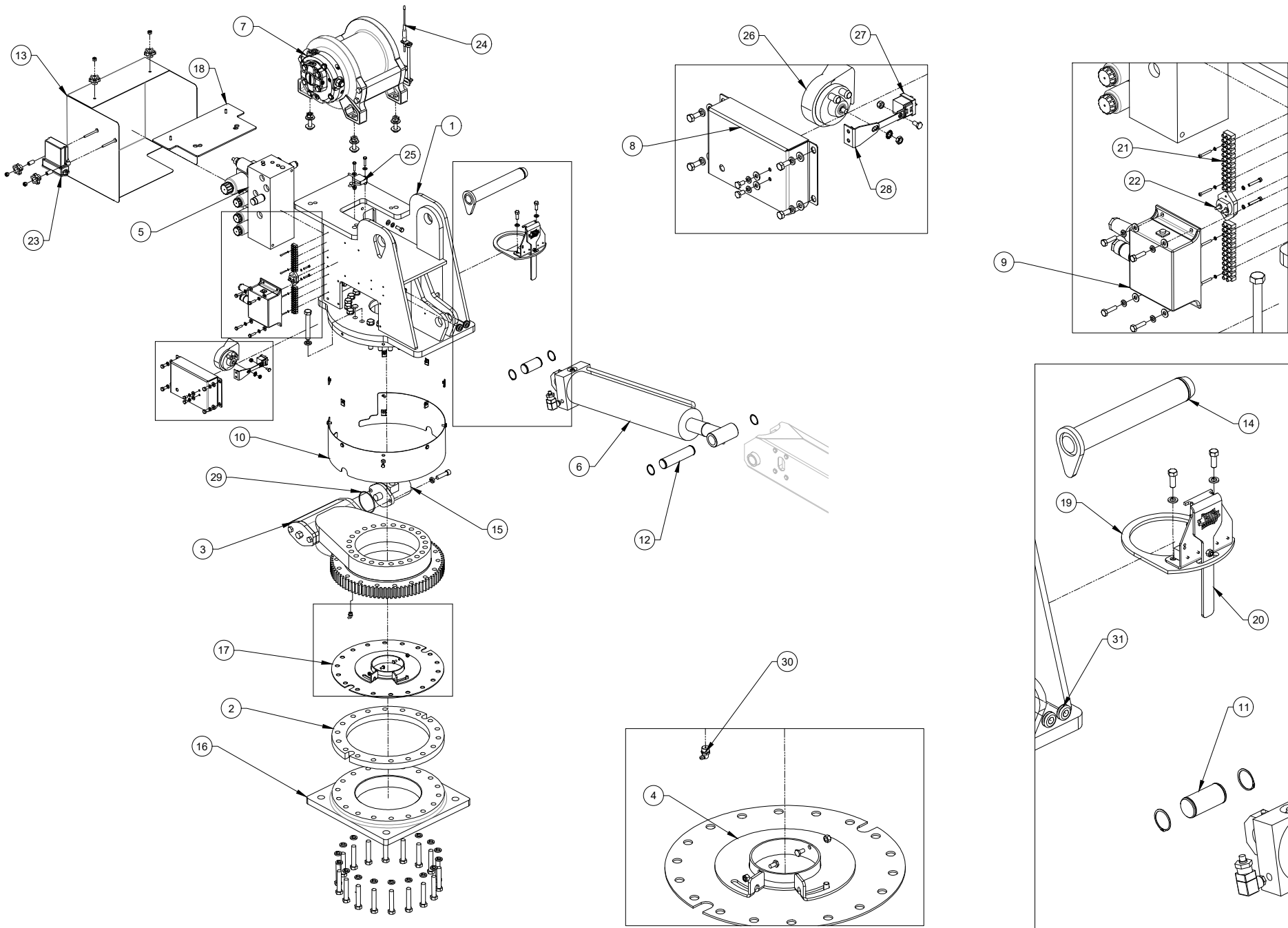

REFERENCE 26902 FOR REPLACEMENT PARTS LIST



VENCO VENTURO INDUSTRIES LLC
CINCINNATI, OHIO

TITLE
REPLACEMENT PARTS DRWNG - MECHANISM

DATE
05-25-23

SECTION
C400

HT45KX VLC SERIES

SUPERSEDES
-

26901

REPLACEMENT PARTS LIST - HT45KX VLC SERIES; MECHANISM

ITEM	QTY.	PART NUMBER	DESCRIPTION
1	1	26600	WELDED ASSEMBLY; HOUSING, MECHANISM
2	1	23662	SPACER PLATE
3	1	22704	SLEWING RING
4	1	24920	STOP DISK
5	1	22736H	HYDRAULIC VALVE MANIFOLD
6	1	21747	ELEVATION CYLINDER
7	1	22829	HYDRAULIC WINCH
8	2	22715-1	HOUSING SIDE COVER
9*	1	23720-RX	RECEIVER; ESCAN, 2.4GHZ
10	1	23644	SLEWING RING COVER
11	1	22256	ELEVATION CYLINDER PIN - INBOARD
12	1	22257	ELEVATION CYLINDER PIN - OUTBOARD
13	1	22842	REAR COVER
14	1	22721	PIVOT PIN - MAIN BOOM PIVOT
15	1	19177	HYDRAULIC ROTATION MOTOR
16	1	26606	MACHINED BASE
▲ 17	1	23626	SLIPPER PLATE WELD
18	1	28319	REAR COVER MOUNTING PLATE WELDEMENT
19	1	23680	HOUSING WATER DAM
20	1	28474	ELECTRIC ROTATION STOP ASSEMBLY

ITEM	QTY.	PART NUMBER	DESCRIPTION
21	2	19187-12	TERMINAL STRIP; 12 SECTIONS
22	1	15683-20A	CIRCUIT BREAKER; 20A
23*	1	23720-VCM	VALVE CONTROL MODULE
24	1	28450	REMOTE ANTENNA
25*	1	23720-INC	UNIVERSAL INCLINOMETER
26	1	21948	HORN
27	1	22739	HIGH CAPACITY RELAY
28	1	22000	BRACKET; HORN
29	1	OR-152-5	O-RING; ROTATION MOTOR
30	1	IZERK-013-27 NPT-90	FITTING; GREASE, 90°
31	2	14775	GROMMET - RUBBER
32	-		
33	-		
34	-		
35	-		
36	-		
37	-		
38	-		
39	-		
40	-		

* THESE ITEMS ARE INCLUDED IN 23720 KIT. PLEASE CALL TECHNICAL SUPPORT AT 1-800-226-2238 FOR ASSISTANCE.

REFERENCE 26901 FOR REPLACEMENT PARTS DRAWING



VENCO VENTURO INDUSTRIES LLC
CINCINNATI, OHIO

TITLE

REPLACEMENT PARTS LIST - MECHANISM

HT45KX VLC SERIES

DATE

11-11-24A

SUPERSEDES

05-25-23

SECTION

C400

26902

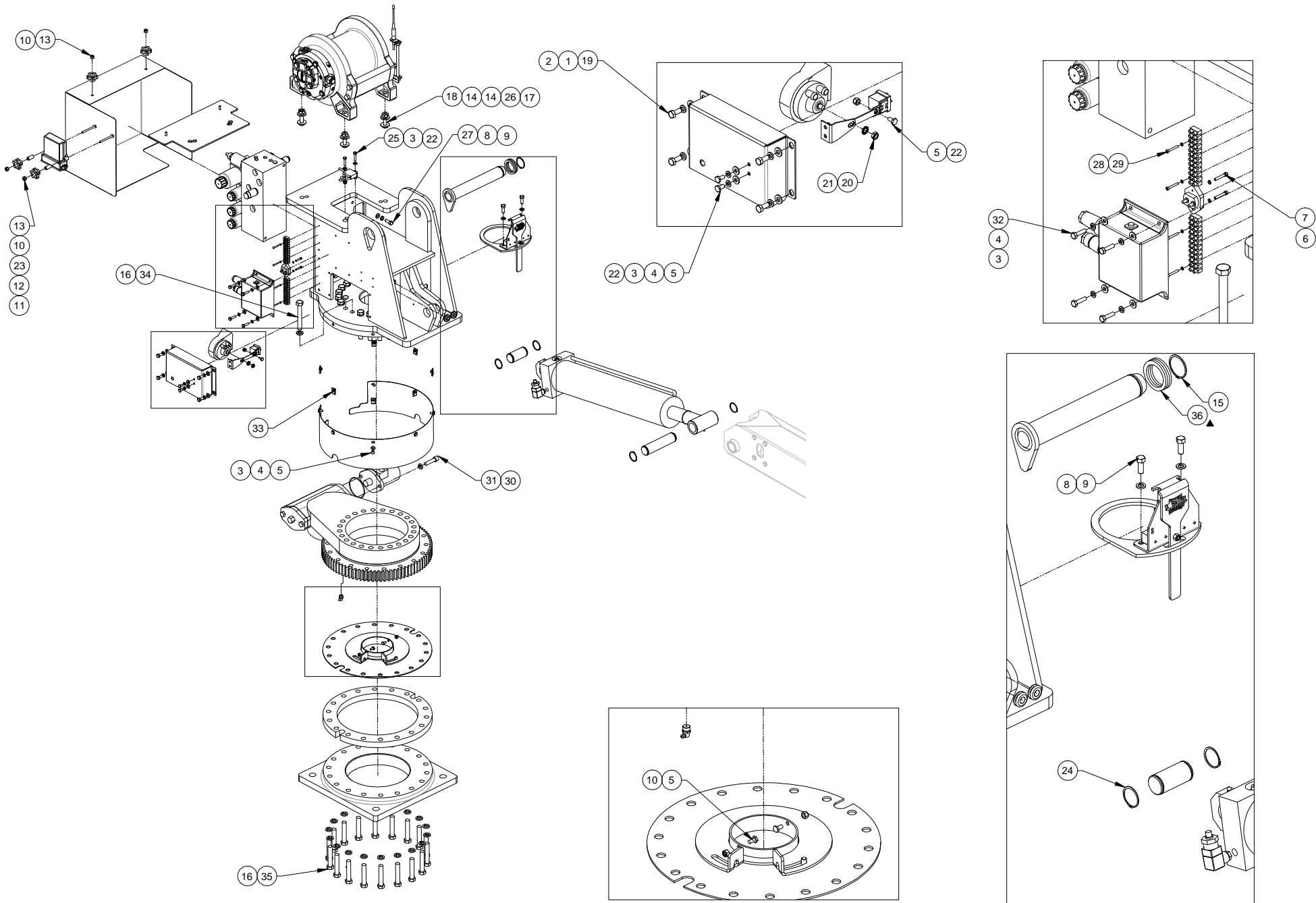

REFERENCE 26904 FOR REPLACEMENT PARTS LIST



VENCO VENTURO INDUSTRIES LLC
CINCINNATI, OHIO

TITLE
RPLCMNT FASTENERS DRWNG - MECHANISM
HT45KX VLC SERIES

DATE
03-29-24A
SUPERSEDES
05-25-23

SECTION
C400
26903

REPLACEMENT PARTS LIST - HT45KX VLC SERIES; MECHANISM

ITEM	QTY.	PART NUMBER	DESCRIPTION
1	8	!LWSH-031S	LOCK WASHER; 5/16", S/S
2	8	!FWSH-031S	FLAT WASHER; 5/16", S/S
3	13	!FWSH-025S	FLAT WASHER; 1/4", S/S
4	11	!LWSH-025S	LOCK WASHER; 1/4", S/S
5	10	!HHCS02520050S	HHCS; 1/4-20 x 1/2" LG, S/S
6	2	!LWSH-#08S	LOCK WASHER; #8, S/S
7	2	!SHCS#0832100S	SHCS; #8-32 X 1", S/S
8	4	!LWSH-038	LOCK WASHER; 3/8", ZINC-PLTD
9	4	!HHCS03816100	HHCS; 3/8-16 X 1", ZINC-PLTD
10	4	28327	KNOB, HAND, 5-POINT
11	2	!HHCS02520275	HHCS, 1/4-20 X2.75", S/S, FULL THREAD
12	2	!JNUT-02520NS	JNUT, NYLON INSERT, 1/4-20, S/S
13	4	!LNUT-02520-H	LOCK NUT; 1/4-20, HVY PAT, NYLON
14	8	!FWSH-050	FLAT WASHER; 1/2", GR. 8
15	1	!SRNG-175	SNAP RING; 1-3/4", ZINC-PLTD
16	40	!LWSH-063	LOCK WASHER; 5/8", GR. 5, ZINC
17	4	!HNUT-05013-8	HEX NUT; 1/2-13, GR. 8
18	2	!HHCS05013225-8	HHCS; 1/2-13 X 2-1/4" LG, GR 8
19	8	!HHCS03118075S	HHCS; 5/16-18 X 3/4", S/S
20	1	!LWSH-031-STAR	LOCK WASHER; 5/16", ZINC

ITEM	QTY.	PART NUMBER	DESCRIPTION
21	1	!HNUT-03118	HEX NUT; 5/16-18, ZINC
22	5	!LNUT-02520SS	NYLOCK HEX NUT 1/4-20
23	2	28328	NYLON SPACER, BLK - .25"IDX.50"ODX1"LG
24	4	!SRNG-150	SNAP RING; 1-1/2", ZINC-PLTD
25	2	!HHCS02520125S	HHCS; 1/4-20 X 1-1/4", S/S
26	4	!LWSH-050	LOCK WASHER; 1/2", GR. 8, ZINC
27	2	!FWSH-038	FLAT WASHER; 3/8", ZINC-PLTD
28	4	!LWSH-#06S	LOCK WASHER; #06, S/S
29	4	!PHPMS#0632100S	PHILIPS-HD PMS; #6-32 X 1", S/S
30	2	!LWSH-050-HC	LOCK WASHER; 1/2", HI-COLLAR
31	2	!SHCS05013200	SOCKET HEAD CAP SCREW - 1/2-13 X 2 LG
32	4	!HHCS02520100S	HHCS; 1/4-20 X 1-1/4", S/S
33	5	!UNUT-02520-LKG	U-NUT 1/4-20, LOCKING TYPE
34	20	!HHCS06311450	HHCS; 5/8-11 x 4.5" LG, GR. 5, ZINC
35	20	!HHCS06311350	HHCS; 5/8-11 x 3.5" LG, GR. 8, ZINC
36	2	26609	SHIM - STAINLESS STEEL
37	-		
38	-		
39	-		
40	-		

HHCS = HEX HEAD CAP SCREW, SHCS = SOCKET HEAD CAP SCREW, PMS = PAN MACHINE SCREW, S/S = STAINLESS STEEL

REFERENCE 26903 FOR REPLACEMENT PARTS DRAWING



VENCO VENTURO INDUSTRIES LLC
CINCINNATI, OHIO

TITLE

RPLCMNT FASTENERS LIST - MECHANISM

HT45KX VLC SERIES

DATE

03-29-24A

SUPERSEDES

05-25-23

SECTION

C400

26904

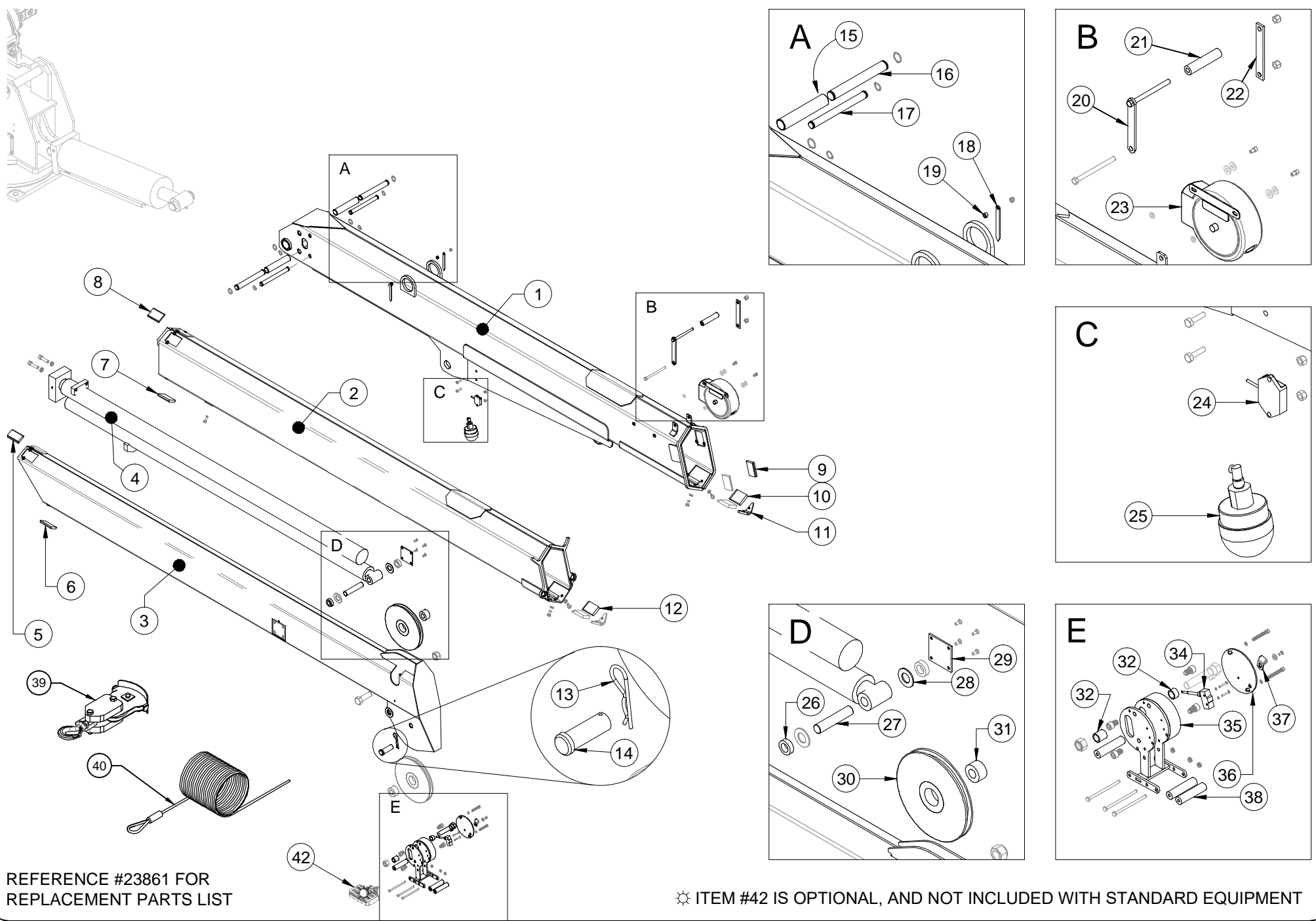

REFERENCE #23861 FOR REPLACEMENT PARTS LIST

☼ ITEM #42 IS OPTIONAL, AND NOT INCLUDED WITH STANDARD EQUIPMENT



VENCO VENTURO INDUSTRIES LLC
CINCINNATI, OHIO

TITLE
RPLCMNT PARTS DRAWING - 23107 BOOM
HT45/55/60KX-25' VLC SERIES

DATE
01-03-23E
SUPERSEDES
12-01-22D

SECTION
C400
23860

REPLACEMENT PARTS LIST - 23107 BOOM

ITEM	PART NO.	QTY	DESCRIPTION
1	27172	1	WELDED ASS'Y; PRIMARY BOOM
2	27175	1	WELDED ASS'Y; SECONDARY BOOM
3	23105	1	WELDED ASS'Y; TERTIARY BOOM
4	21749	1	EXTENSION CYLINDER
5	23217-1	2	BOOM PAD; UHMW, 'A', 3.19 x 1.88 x 0.50
6	23217-1	2	BOOM PAD; UHMW, 'A', 3.19 x 1.88 x 0.44
7	23217-2	2	BOOM PAD; UHMW, 'A', 3.19 x 2.13 x 0.44
8	23217-2	2	BOOM PAD; UHMW, 'A', 3.19 x 2.13 x 0.44
9	23217-13	2	BOOM PAD; UHMW, 'A', 3.19 x 2.13 x 0.38
10	23217-17	2	BOOM PAD; UHMW, 'B', 3.19 x 2.50 x 0.50
11	23183	2	V-BLOCK, SLIDER
12	23217-14	2	BOOM PAD; UHMW, 'B', 3.19 x 2.13 x 0.50
13	21-08	1	PIN; HAIRPIN COTTER
14	27272	1	CLEVIS PIN
15	24535	2	THRUST ROLLER; EXTENSION CYLINDER
16	22255	2	THRUST PIN; REAR, EXTENSION CYLINDER
17	22255	2	THRUST PIN; FRONT, EXTENSION CYLINDER
18	13459-2	2	ARROW
19	22490	2	SPACER; BOOM ARROW
20	21935	1	WELDED ASS'Y; WIRE ROPE GUIDE
21	21560	1	ROLLER; UHMW, WIRE ROPE GUIDE
-	-	-	-
-	-	-	-

* THESE ITEMS ARE INCLUDED IN 23720 KIT

** NOT SHOWN ON DRAWING

ITEM	PART NO.	QTY	DESCRIPTION
22	21936	1	FLAT, MOUNT; WIRE ROPE GUIDE
23	28190-1	1	COMPLETE CORD REEL
24*	23720-INC	1	UNIVERSAL INCLINOMETER (VLC)
25	23438	1	WARNING LIGHT; TRI-COLOR, LED (VLC)
26	21428	2	BUSHING; EXTENSION CYLINDER
27	21405	1	PIN; PIVOT, EXTENSION CYLINDER
28	!FWSH-100SAE	2	FLAT WASHER; 1" SAE
29	23116	2	PIN BLOCK REINFORCING
30	23928	2	CABLE SHEAVE
31	23929	2	SPACER; SHEAVE
32	27476-1	2	SPACER; COMPACT A2B
33	-	-	-
34	19376	1	LIMIT SWITCH; MODIFIED
35	27468	1	WLDMNT; COMPACT A2B FRAME, LEFT-HAND
36	27473	1	PLATE; COMPACT A2B COVER
37	19269	1	CLAMP; 1/4" CABLE
38	27475	3	ROLLER; COMPACT A2B, WIRE ROPE GUIDE
39	17949-1	1	LOAD BLOCK ASSEMBLY (HT40) ▲
	17949-2	1	LOAD BLOCK ASSEMBLY (HT45) ▲
	17949	1	LOAD BLOCK ASSEMBLY (HT50) ▲
	17949-3	1	LOAD BLOCK ASSEMBLY (HT55)
	17949-5	1	LOAD BLOCK ASSEMBLY (HT60)
40**	17094-3/8-100	1	WIRE ROPE; 100 FT, NO HOOK (HT40/45/50/55)
	24916-3/8-100	1	WIRE ROPE; 100 FT, NO HOOK (HT60)
☼42	27483	1	ASS'Y; WORK LIGHT, LED

REFERENCE #23860 FOR REPLACEMENT PARTS DRAWING

☼ OPTIONAL; NOT INCLUDED WITH STANDARD EQUIPMENT



VENCO VENTURO INDUSTRIES LLC
CINCINNATI, OHIO

TITLE	REPLACEMENT PARTS LIST - 23107 BOOM	DATE	04-24-24M	SECTION	C400
	HT40/45/50/55/60KX-25'	SUPERSEDES	03-26-24L		23861

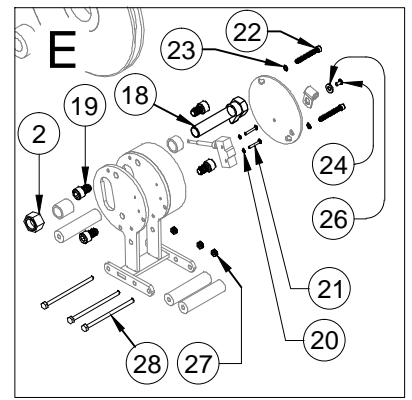
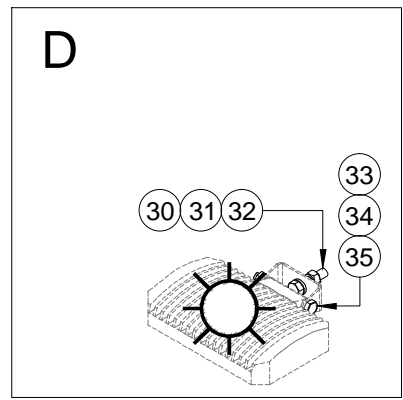
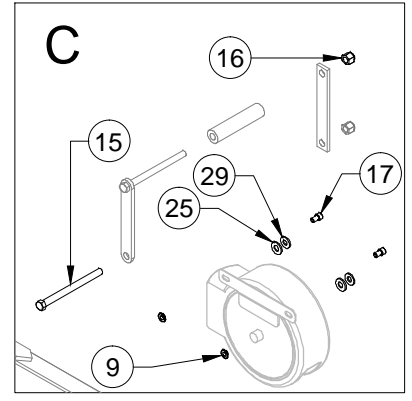
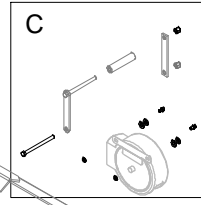
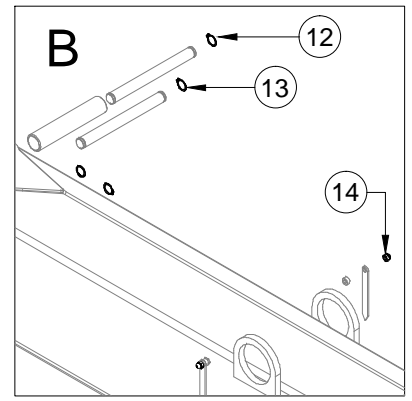
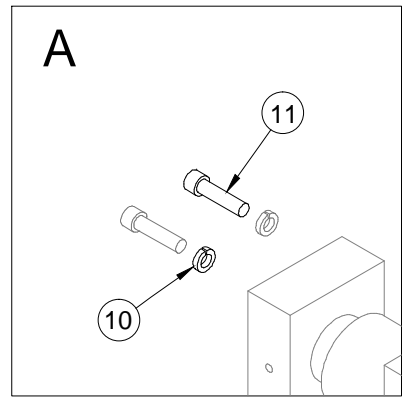
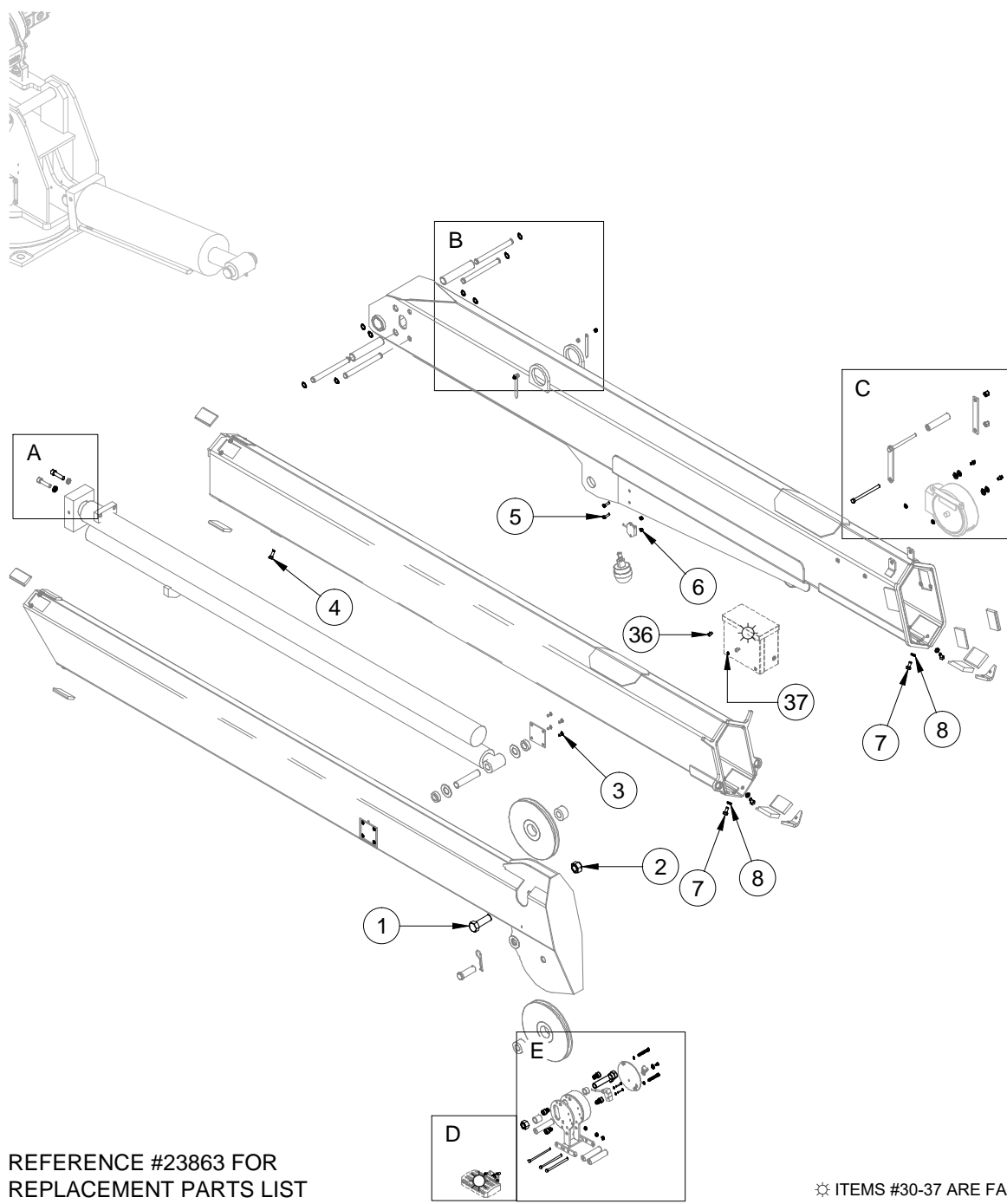

REFERENCE #23863 FOR REPLACEMENT PARTS LIST

⚙️ ITEMS #30-37 ARE FASTENERS FOR OPTIONAL COMPONENTS - NOT INCLUDED WITH STANDARD EQUIPMENT



VENCO VENTURO INDUSTRIES LLC
CINCINNATI, OHIO

TITLE	RPLCMNT FASTENERS DRWNG - 23107 BOOM
TITLE	HT45/55/60KX-25' VLC SERIES

DATE	01-03-23C
SUPERSEDES	02-22-21A

SECTION	C400
SECTION	23862

ITEM #	PART #	QTY	DESCRIPTION	WHERE-USED
1	17059-6	1	SHEAVE AXLE; HHCS, 3/4-10 X 2", S/S	TOP SHEAVE
2	!LNUT-07510	2	LOCK NUT, FULL, 3/4-10, GR. 5, ZINC	SHEAVES
3	!CACS02520050S	8	CACS; 1/4-20 X 1/2", S/S	PIN BLCK REINFORCING
4	!HHCS02520125S	2	HHCS; 1/4-20 X 1-1/4", S/S	EXTENSION CYLINDER
5	!HHCS02520100S	2	HHCS; 1/4-20 X 1", S/S	INCLINOMETER
6	!LNUT-02520NS	2	LOCK NUT; 1/4-20, NYLON, S/S	INCLINOMETER
7	!HHCS03816075S	4	HHCS; 3/8-16 X 3/4", S/S	V-BLOCKS
8	!LWSH-038	4	LOCK WASHER; 3/8", GR. 5, ZINC-PL	V-BLOCKS
9	28198	2	INSULATING SLEEVE WASHER - 5/16"	CORD REEL
10	!LWSH-050-HC	2	LOCK WASHER; 1/2", HI-COLLAR	EXTENSION CYLINDER
11	!SHCS05013200	2	SHCS; 1/2-13 X 2"	EXTENSION CYLINDER
12	!SRNG-075	4	SNAP RING; 3/4"	EXT. CYL. REAR PINS
13	!SRNG-075	4	SNAP RING; 3/4"	EXT. CYL. FRONT PINS
14	!ANUT-02520S	2	ACORN NUT; 1/4-20, S/S	BOOM ARROWS
15	!HHCS04414550	1	HHCS; 7/16-14 X 5-1/2", GR. 5, ZINC	WIRE ROPE GUIDE
16	!LNUT-04414	2	LOCK NUT; 7/16-14, GR. 5, ZINC	WIRE ROPE GUIDE
17	!SHCS03118063S	2	SHCS; 5/16-18 X 5/8" LG, S/S	CORD REEL
18	28362	1	ASSY, CAM & HHCS CA2B CUT-OUT	COMPACT A2B ASS'Y
19	27467	4	SHCS; 1/2-13 X 3/4", BLACK NYLON	COMPACT A2B ASS'Y
20	!LWSH-#06	2	LOCK WASHER; #06, ZINC	COMPACT A2B SWITCH

ITEM #	PART #	QTY	DESCRIPTION	WHERE-USED
21	!PHCS#0632100	2	PHCS; #06-32 X 1", GR. 5, ZINC	COMAPCT A2B SWITCH
22	!SHCS02520200SS	2	SHCS; 1/4-20 X 2", S/S	COMPACT A2B COVER
23	23379	2	WASHER; 3/8" ID, 1/4" OD, NYLON	COMPACT A2B COVER
24	!SHPMS#1032038S	1	SLOT-HD PMS; #10-32 X 3/8", S/S	COMPACT A2B CLAMP
25	01016	2	FIBER WASHER	CORD REEL
26	!FWSH-025S	1	FLAT WASHER; 1/4", S/S	COMPACT A2B CLAMP
27	!JNUT-02520NS	3	JAM NUT; 1/4-20, NYLON, S/S	COMPACT A2B ROLLERS
28	!HHCS02520450	3	HHCS; 1/4-20 X 4-1/2"	COMPACT A2B ROLLERS
29	!FWSH-031	2	FLAT WASHER, 5/16"	CORD REEL
☼ 30	!HHCS03118125S	1	HHCS; 5/16-18 X 1-1/4", S/S	WORK LIGHT
☼ 31	!HNUT-03118S	2	HEX NUT; 5/16-18, S/S	WORK LIGHT
☼ 32	!FWSH-031S	1	FLAT WASHER; 5/16", S/S	WORK LIGHT
☼ 33	!HHCS02520250S	1	HHCS; 1/4-20 X 2-1/2", S/S	WORK LIGHT
☼ 34	!LWSH-025S	1	LOCK WASHER; 1/4", S/S	WORK LIGHT
☼ 35	!HNUT-02520S	1	HEX NUT; 1/4-20, S/S	WORK LIGHT
☼ 36	!SHCS03118050-SS	2	SHCS; 5/16-18 X 1/2", S/S	22683-1
☼ 37	!PHCS#1032025	2	PHCS; #10-32 X 1/4", GR. 5, ZINC	22683-1 COVER
38	-	-	-	-
39	-	-	-	-
40	-	-	-	-

☼ ITEMS #30-37 ARE FOR OPTIONAL COMPONENTS - NOT INCLUDED WITH STANDARD EQUIPMENT

REFERENCE #23862 FOR REPLACEMENT FASTENERS DRAWING

HHCS = HEX HEAD CAP SCREW PMS = PAN MACHINE SCREW S/S = STAINLESS STEEL



VENCO VENTURO INDUSTRIES LLC
CINCINNATI, OHIO

TITLE	DATE	SECTION
PLCMNT FASTENERS LIST - 23107 BOOM	01-03-23C	C400
HT45/55/60KX-25' VLC SERIES	SUPERSEDES	23863
	11-29-22B	

Compact A2B with Stowage Cut-out, Install/Adjustment Instructions (Kit: 28375)

The purpose of the Stowage Cut-out system is to prevent a situation whereby the wire rope is over-tensioned when the load block / wire rope is attached to the stowage hook on the bottom of the primary boom assembly. **However, the OPERATOR is ultimately responsible for ensuring that the wire rope is not over-tensioned when stowing the wire rope and boom assembly into the boom rest.**

1. Initially, apply a light torque to the nyloc full nut Item #1 (P/N !LNUT-07510), such that the axle bolt & cam welded assembly can be rotated / adjusted in the steps below.
2. Position the cam **lobe** Item #2 (P/N 28362) so that it is pointing towards the housing / mechanism
3. Hang the load block on the open stowage hook under the primary boom.
4. Thread the wire rope through the load block in a two-line configuration; the wire rope end / eyelet is pinned in the standard position on the tertiary boom tip
5. Actuate the Winch Up function until the load block and wire rope are **taut** enough to prevent the load block from bouncing during transit, **but do not tighten excessively so as to prevent damage to the wire rope.**
6. Rotate the axle bolt & cam welded assembly towards the housing (clockwise in standard configuration) until the cam lobe makes contact with and trips the wobble micro switch and actuates the A2B function.
7. Once adjusted, torque the nyloc full nut (Item #1) to 100 ft*lbs to prevent further rotational movement of the axle bolt & cam welded assembly.
8. Test the A2B trip-point by slackening and tightening the wire rope / load block assembly by actuating Winch Up/Down. **NOTE: The point at which the A2B trips WILL vary to some degree, depending upon the winch up speed. It is recommended to actuate the winch up function slowly, which will yield a consistent and repeatable result, in terms of wire rope tension when stowed.**

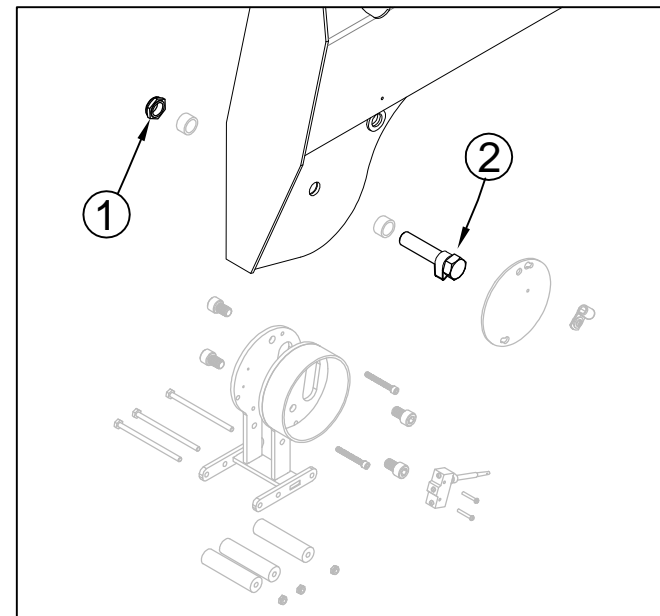

Contact Ventura Tech Support for assistance. 1-800-226-2238 ext. 124



VENCO VENTURO INDUSTRIES LLC
CINCINNATI, OHIO

TITLE
A2B Stowage Cut-out

ET/HT Cranes w/ Comp. A2B

DATE
10-04-21B

SUPERSEDES
08-03-21A

SECTION
C400

28239

T11 & T12 WINCH REPLACEMENT PARTS DRAWING

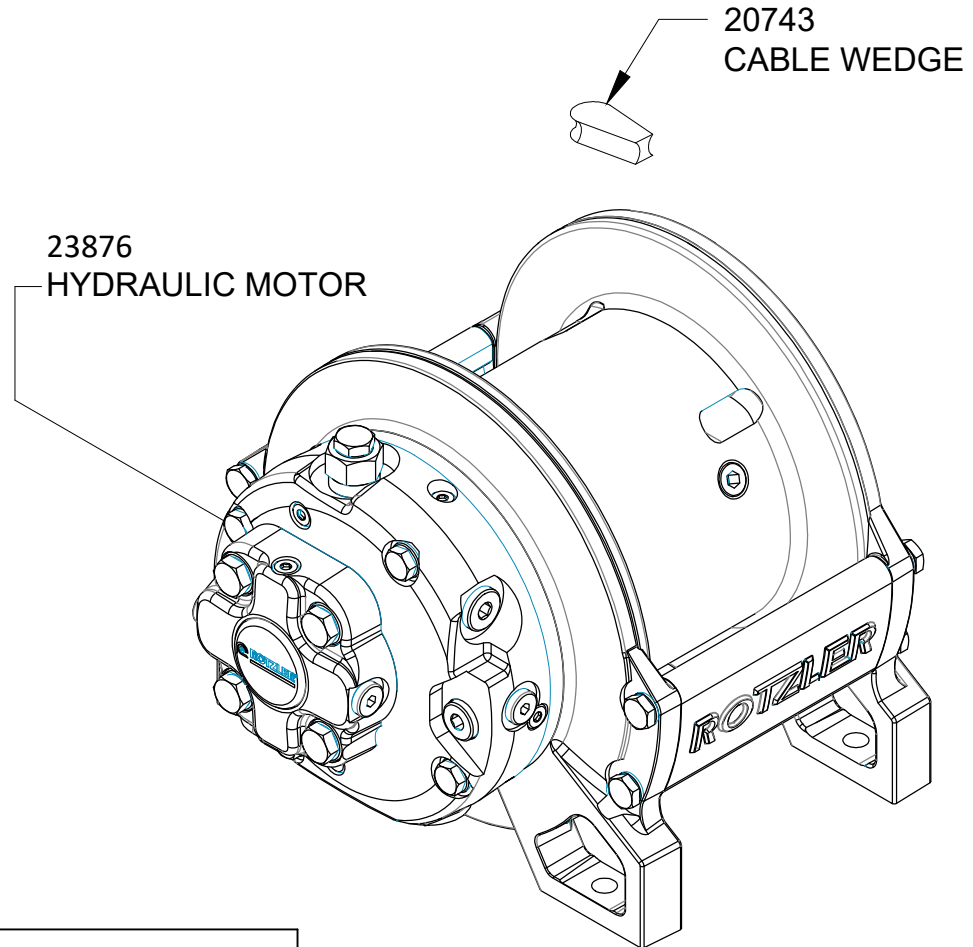

WINCH SEALS PACKAGE	
T11	T12
23874	23848



VENCO VENTURO INDUSTRIES LLC
CINCINNATI, OHIO

TITLE
T11 & T12 REPLACEMENT PARTS DRAWING

HT40/45/50KX

DATE
05-30-23

SUPERSEDES
-

SECTION
C400

26896

REPLACEMENT PARTS DRAWING, HYDRAULIC COMPONENTS

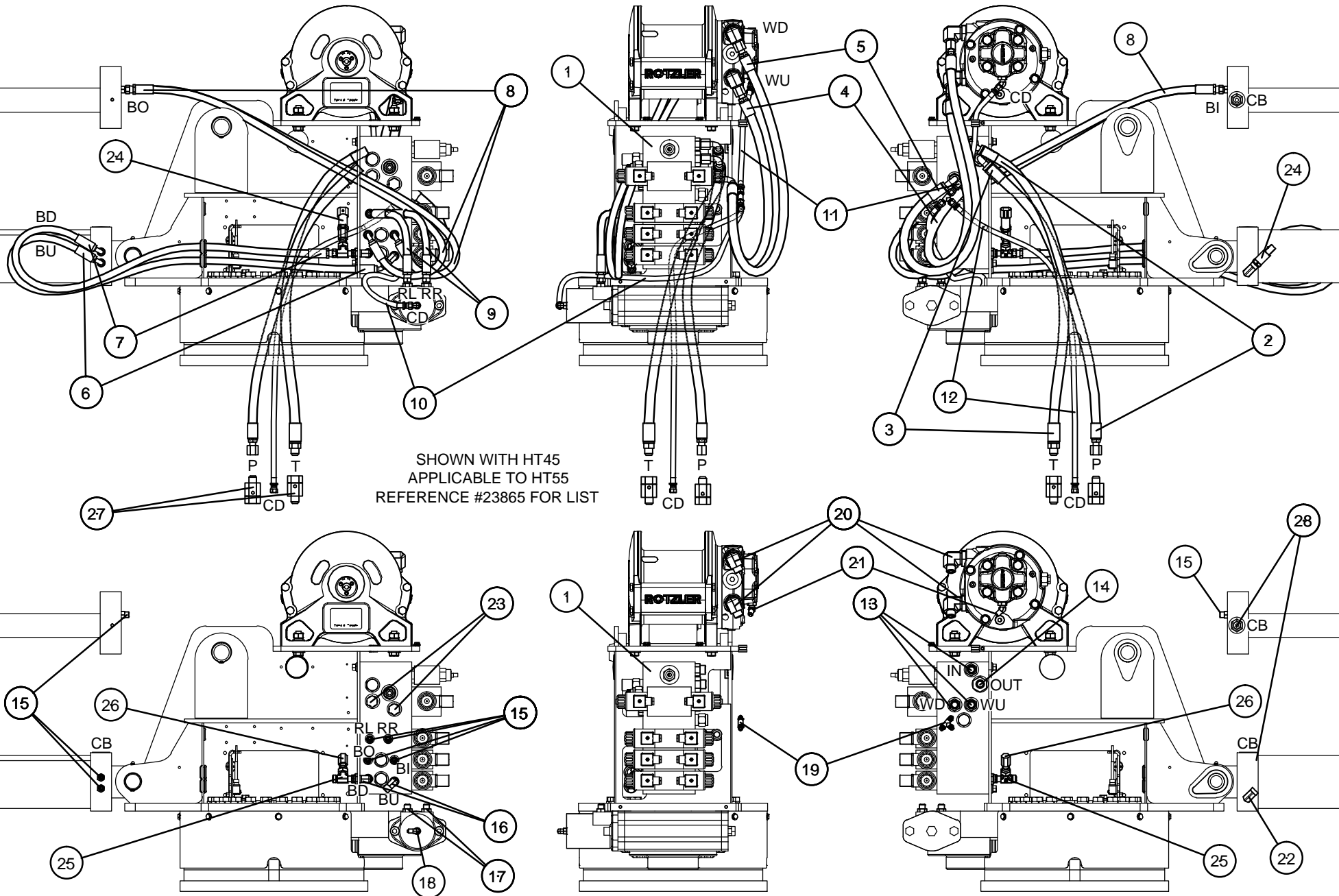

VENCO VENTURO INDUSTRIES LLC
CINCINNATI, OHIO

TITLE
REPLACEMENT PARTS, HYD. COMPONENTS
HT45/55 VLC SERIES CRANES

DATE
04-27-21D
SUPERSEDES
03-25-21C

SECTION
C400
23864

REPLACEMENT PARTS LIST; HYDRAULIC COMPONENTS

#	DESCRIPTION	QTY	PART NUMBER	APPLICATION
1	VALVE MANIFOLD; PROPORTIONAL, HT40-55KX	1	22736H	REAR OF MECHANISM, INSIDE REAR COVER
2	HOSE ASSEMBLY; PRESSURE SUPPLY	1	23798	RIGHT SIDE VALVE BANK TO COMPARTMENT SIDE
3	HOSE ASSEMBLY; RETURN SUPPLY	1	23799	RIGHT SIDE VALVE BANK TO COMPARTMENT SIDE
4	HOSE ASSEMBLY; WINCH UP	1	27024	RIGHT SIDE VALVE BANK TO WINCH UP PORT
5	HOSE ASSEMBLY; WINCH DOWN	1	27025	RIGHT SIDE VALVE BANK TO WINCH DOWN PORT
6	HOSE ASSEMBLY; BOOM UP	1	27026	LEFT SIDE VALVE BANK TO BOOM UP PORT
7	HOSE ASSEMBLY; BOOM DOWN	1	27027	LEFT SIDE VALVE BANK TO BOOM DOWN PORT
8	HOSE ASSEMBLY; BOOM IN & OUT	2	27592	EXTENSION PORTS TO LEFT SIDE VALVE BANK
9	HOSE ASSEMBLY; ROTATION LEFT & RIGHT	2	27598	LEFT SIDE VALVE BANK TO ROTATION PORTS
10	HOSE ASSEMBLY; WINCH CASE DRAIN	1	22952	ROTATION CASE DRAIN TO T-FITTING JUNCTION
11	HOSE ASSEMBLY; ROTATION CASE DRAIN	1	22953	WINCH CASE DRAIN TO T-FITTING JUNCTION
12	HOSE ASSEMBLY; CASE DRAIN OUT	1	22903	T-FITTING JUNCTION TO COMPARTMENT SIDE
13	FITTING; ADAPTER, STRAIGHT, 8OFS-10MO	3	FF6400-0810	RIGHT SIDE VALVE BANK; IN, WU & WD PORTS
14	FITTING; ADAPTER, STRAIGHT, 8OFS-12MO	1	FF6400-0812	RIGHT SIDE VALVE BANK, OUT PORT
15	FITTING; ADAPTER, STRAIGHT, 6OFS-6MO	8	FF6400-0606	ELEVATION, EXTENSION, RL, RR, BI & BO PORTS
16	FITTING; ADAPTER, 90° ELBOW, 6OFS-6MO	2	FF6801-0606	LEFT SIDE VALVE BANK, BU & BD PORTS
17	FITTING; ADAPTER, STRAIGHT, 6OFS-10MO	2	FF6400-0610	ROTATION RIGHT & LEFT PORTS
18	FITTING; ADAPTER, 90° ELBOW, 4MJ-4MO	1	H6801-0404	ROTATION CASE DRAIN PORT
19	FITTING; ADAPTER, T-SHAPE, 4MJ-4MJ-4MJ	1	H2603-040404	T-FITTING JUNCTION FOR CASE DRAIN HOSES
20	FITTING; ADAPTER, 90° ELBOW, 8OFS-12MO BRITISH	2	FF3801-8-12	WINCH UP & DOWN PORTS, ROTZLER TI SERIES
21	FITTING; ADAPTER, 45° ELBOW, 4MJ-4MO BRITISH	1	3802-0404	WINCH CASE DRAIN PORT, ROTZLER TI SERIES
22	FITTING; ADAPTER, 90° ELBOW, 4MO-4FO	1	23733	ELEVATION BASE-END, PRESSURE TRANSDUCER
23	FITTING; PLUG, 10MO	2	H6408-10	LEFT SIDE VALVE BANK, WU & WD PORTS
24	PRESSURE TRANSDUCER; VLC SYSTEM	2	23720-PTD	BASE-END ON EL. CYLINDER, ROD-END INSIDE MECH
25	FITTING; ADAPTER, T-SHAPE, 6MOFS-6FOFS-6MOFS	1	23731	ROD-END OF EL. CYLINDER, INSIDE MECHANISM
26	FITTING; ADAPTER, STRAIGHT, 6OFS-4MO	1	23732	T-FITTING FOR ROD-END OF EL. CYLINDER
27	LIVE SWIVEL; CONTINUOUS, STRAIGHT, 6MJ-6FJ	2	22764	PRESSURE & RETURN HOSES, COMPARTMENT SIDE
28	COUNTER-BALANCE VALVE; CBPA, 50/40, 3000 PSI SYS.	2	20893	ELEVATION & EXTENSION CYLINDER VALVE

HYDRAULIC FUNCTION KEY

P	PRESSURE SUPPLY	RL	ROTATION LEFT
T	TANK RETURN	RR	ROTATION RIGHT
CD	CASE DRAIN	BO	BOOM OUT
IN	PRESSURE IN	BI	BOOM IN
OUT	RETURN OUT	BU	BOOM UP
WU	WINCH UP	BD	BOOM DOWN
WD	WINCH DOWN	CB	COUNTER-BALANCE VALVE

REFERENCE #23864 FOR REPLACEMENT PARTS DRAWING



VENCO VENTURO INDUSTRIES LLC
CINCINNATI, OHIO

TITLE
REPLACEMENT PARTS LIST
HT45/55 VLC SERIES

DATE
04-27-21E
SUPERSEDES
10-15-20D

SECTION
C400
23865

22736 SERIES VALVE MANIFOLD REPLACEMENT PARTS

22963
CHECK VALVE
(NOT SHOWN -
LOCATED ON BACK SIDE)

22595
MAIN RELIEF VALVE

22967 (HT40/45/50, 22736H & -3) ▲
22595 (HT66, 22736H-1)
22595-2600 (HT60, 22736H-2)
WINCH RELIEF VALVE

22312-2.25
PRIORITY FLOW VALVE
(BOOM EXTENSION)

22312-4.00
PRIORITY FLOW VALVE
(BOOM ELEVATION)

PRIORITY FLOW VALVE		
VALVE P/N	MANIFOLD	CRANE
22312-6.00	22736H	HT40/50
22312-7.50	22736H-1	HT66
22312-7.50	22736H-2	HT60
22312-7.50	22736H-3	HT40/45/50
NOT SHOWN - LOCATED ON RIGHT SIDE		

23046
PROPORTIONAL VALVE

22873
VALVE SECTION ASSY

22523
VALVE SECTION ASSY



VENCO VENTURO INDUSTRIES LLC
CINCINNATI, OHIO

TITLE
22736 REPLACEMENT PARTS

HT40/50/60/66KX PROPORTIONAL

DATE
04-19-24H

SUPERSEDES
11-10-22G

SECTION
C400

22940

WORK LIGHT INSTALLATION: 28240 (3-WIRE CORD REEL ON VLC CRANES)

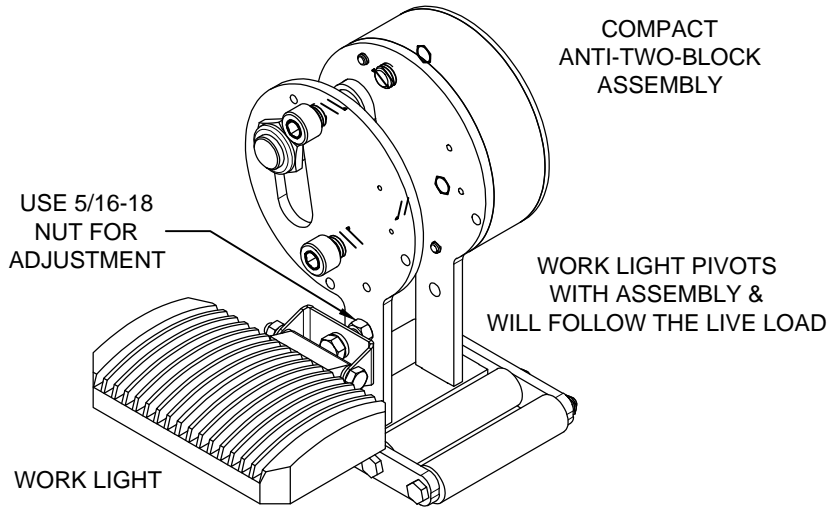

BILL OF MATERIALS		N/D	28240
#	DESCRIPTION	QTY	PART NUMBER
1	IDWG; WORK LIGHT INSTALLATION, VLC CRANES	1	28188
2	LED WORK LIGHT	1	27483
3	TERMINAL; 16G, FEMALE, QUICK-CONNECT	5	!TERM16G250QCFI
4	TERMINAL; 16G, MALE, QUICK-CONNECT	4	!TERM16G250QCM
5	WIRE ASS'Y; 16G, BLACK, 28", #6 RING - STRIPPED END	1	22254-BLK280AO
6	WIRE ASS'Y; 16G, BLACK, 28", QCF - STRIPPED END	1	22254-BLK280GO
7	RELAY; 12VDC	1	22739
8	DECAL; WORK LIGHT RELAY	1	16184-2
9	WIRE ASS'Y; 16G, BLACK, 30", MALE PIN - QCF	2	22254-BLK300FG

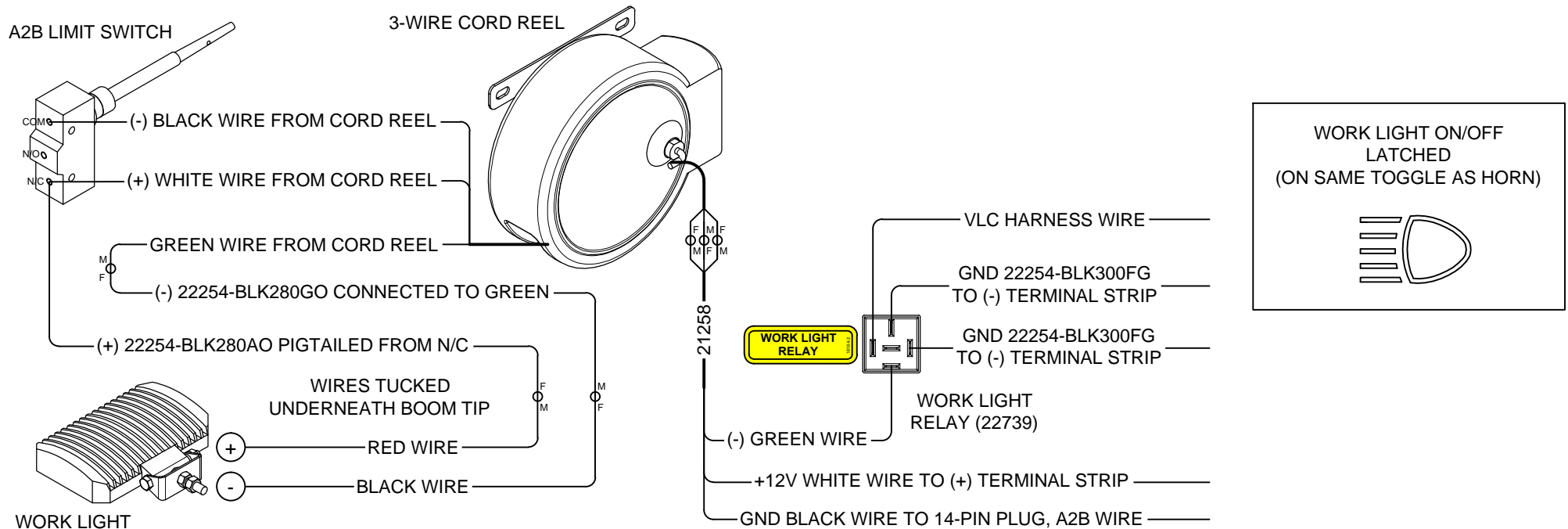

VENCO VENTURO INDUSTRIES LLC
CINCINNATI, OHIO

TITLE
WORK LIGHT INSTALLATION, 3-WIRE CORD REEL
VLC CRANES

DATE
06-12-24B

SECTION
C400

SUPERSEDES
03-03-23A

28188

OPTIONAL WORK LIGHT CIRCUIT

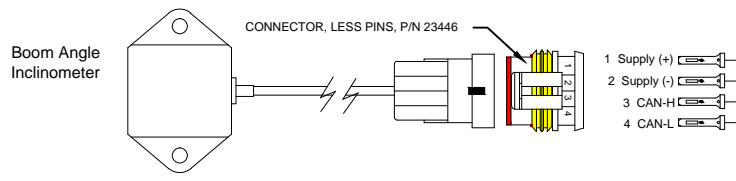
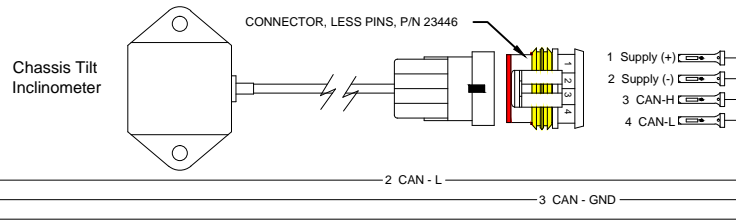
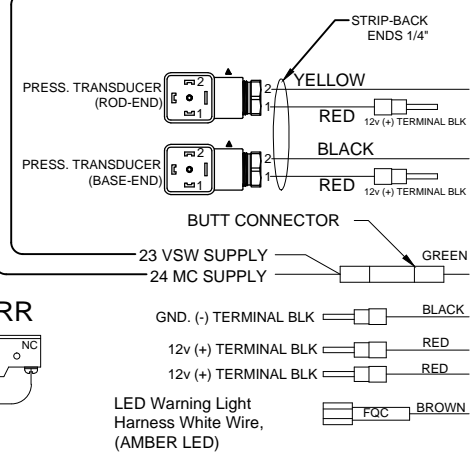
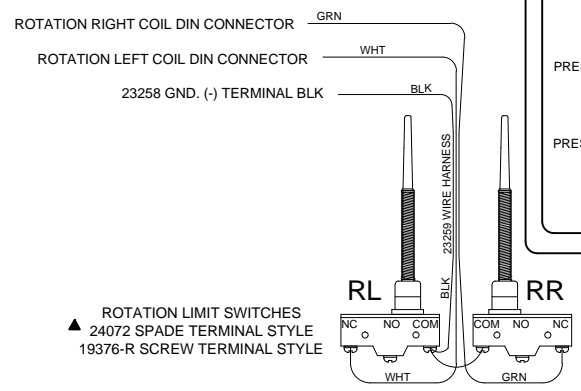
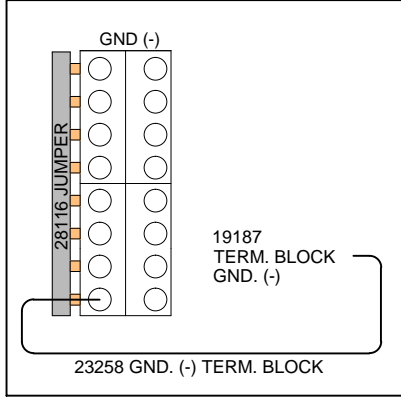
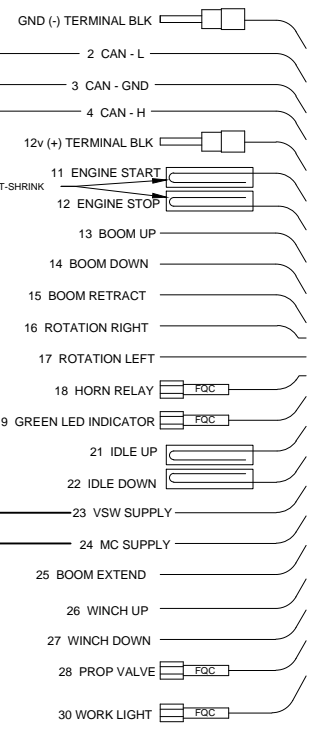
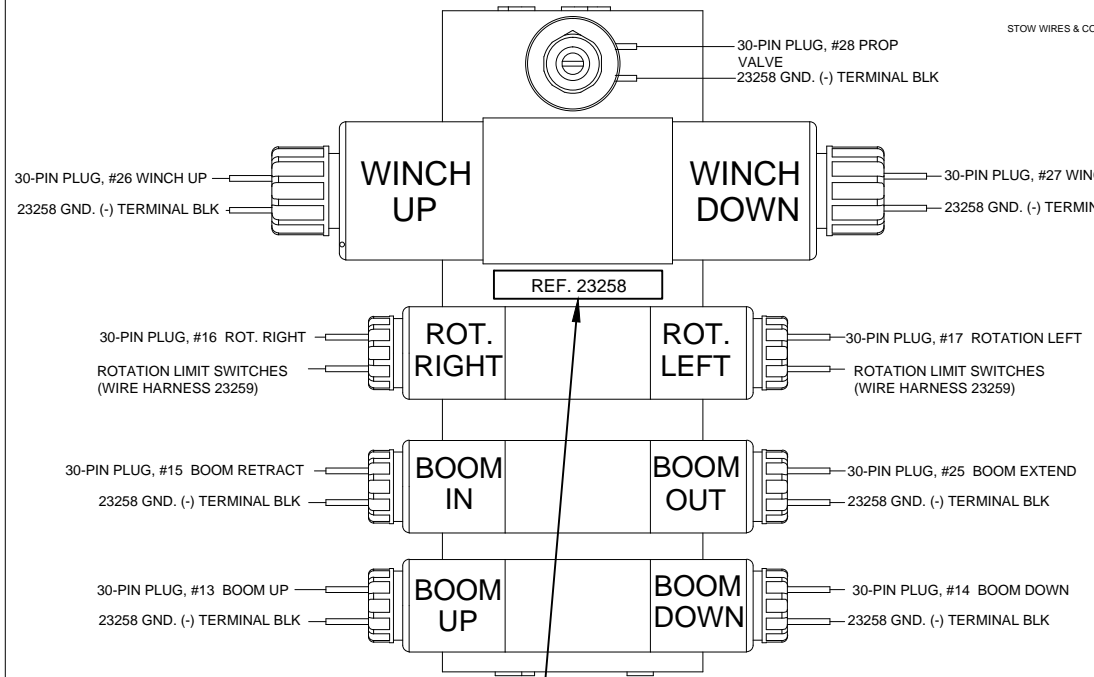
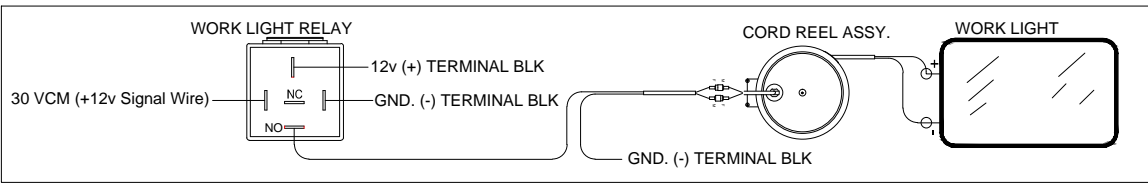

23437 SHOWS RIGHT SIDE OF WIRING DIAGRAM

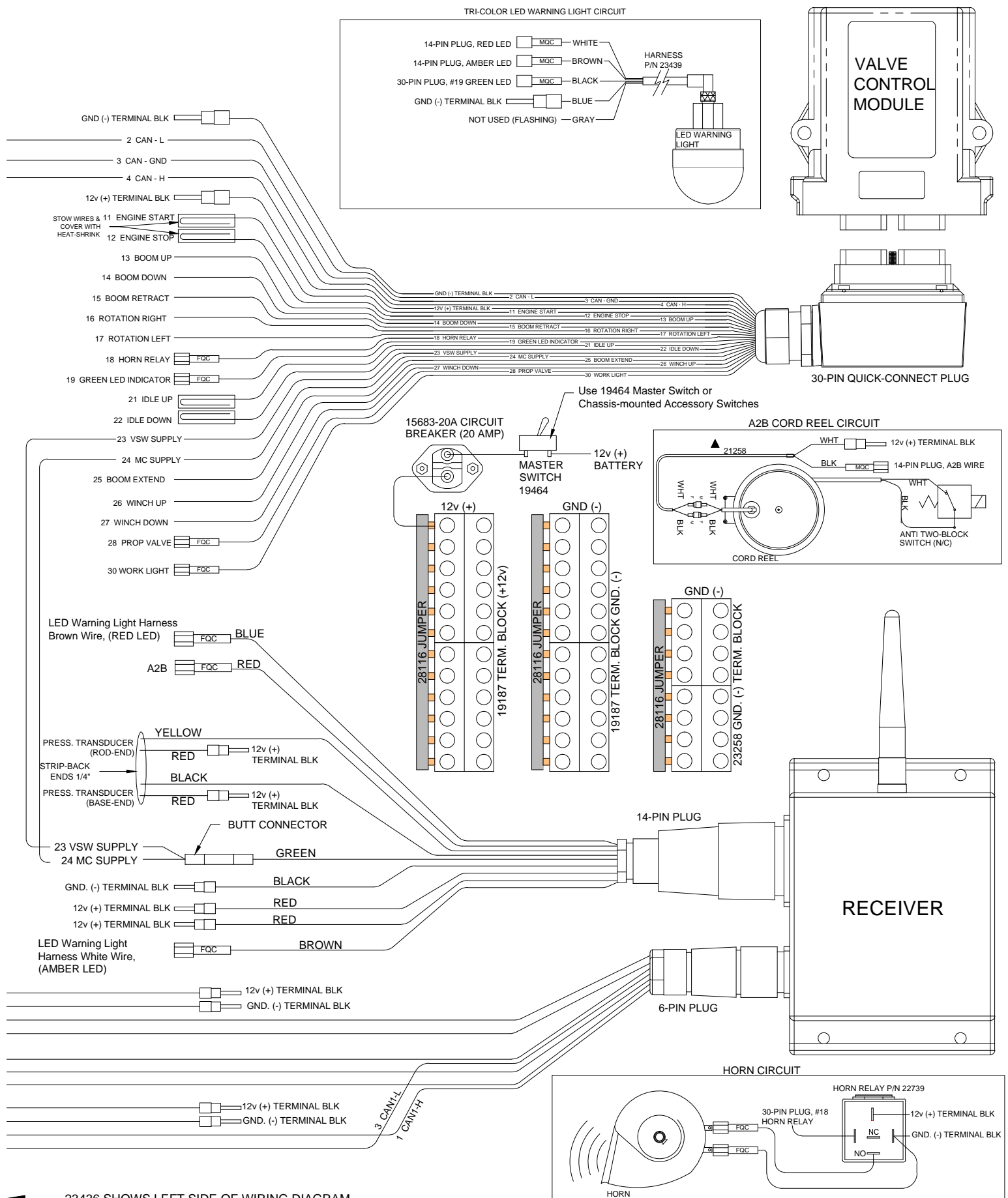

VENCO VENTURO INDUSTRIES LLC
 CINCINNATI, OHIO

TITLE
WIRING DIAGRAM, PG. 2

VLC-H ("RED") SERIES

DATE
07-08-24N

SUPERSEDES
06-14-24M

SECTION
C400

23437

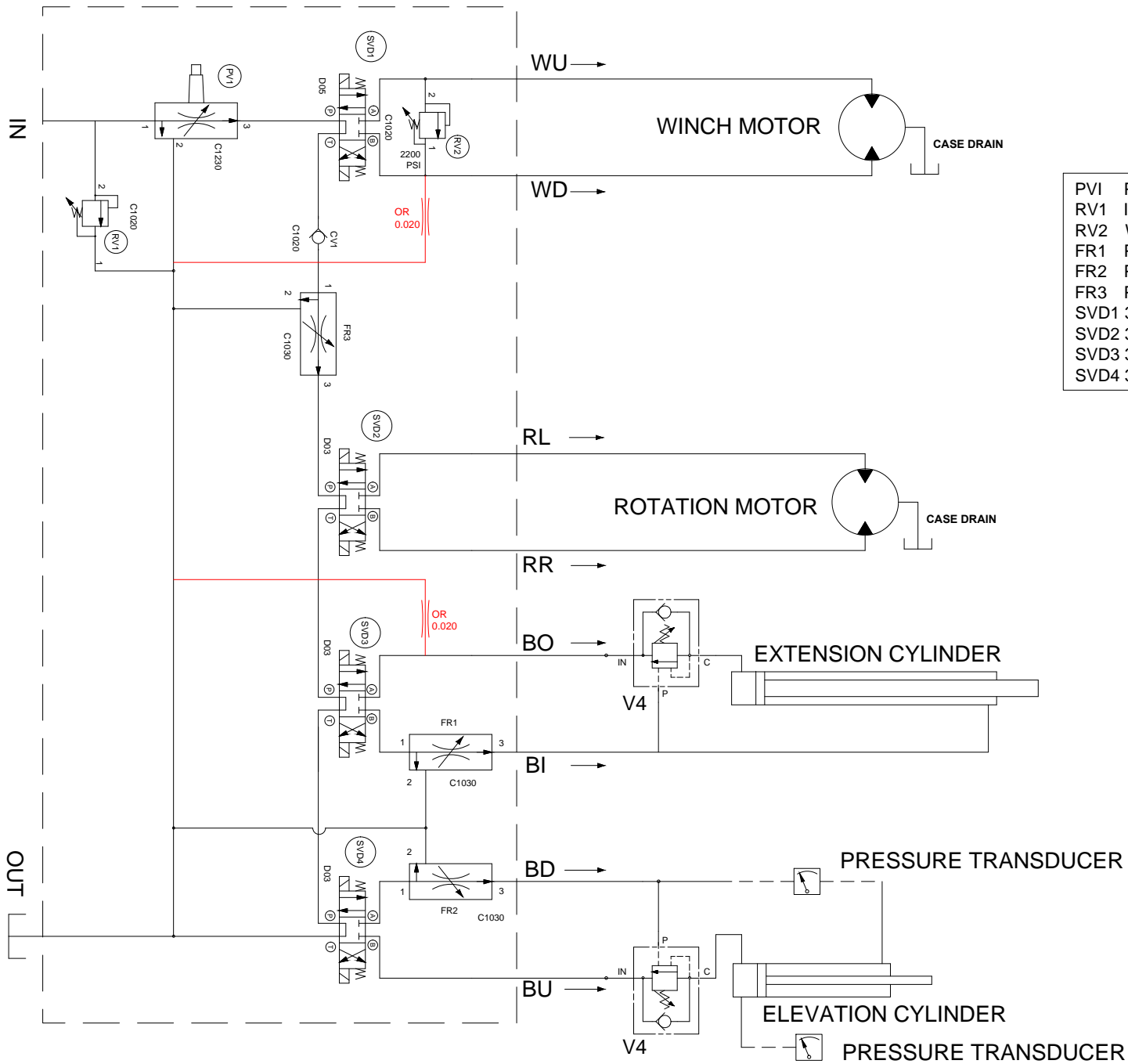

- PVI PROPORTIONAL CONTROL VALVE (SIMPLIFIED REP)
- RV1 INLET RELIEF VALVE ▲
- RV2 WINCH RELIEF VALVE
- FR1 PRIORITY FLOW REGULATOR
- FR2 PRIORITY FLOW REGULATOR ▲
- FR3 PRIORITY FLOW REGULATOR
- SVD1 3 POSITION - 4 WAY VALVE
- SVD2 3 POSITION - 4 WAY VALVE
- SVD3 3 POSITION - 4 WAY VALVE
- SVD4 3 POSITION - 4 WAY VALVE



VENCO VENTURO INDUSTRIES LLC
CINCINNATI, OHIO

TITLE
HYDRAULIC SYSTEM DIAGRAM

HT45/55 VLC SERIES

DATE
06-17-24C

SUPERSEDES
12-04-23B

SECTION
C400

23868

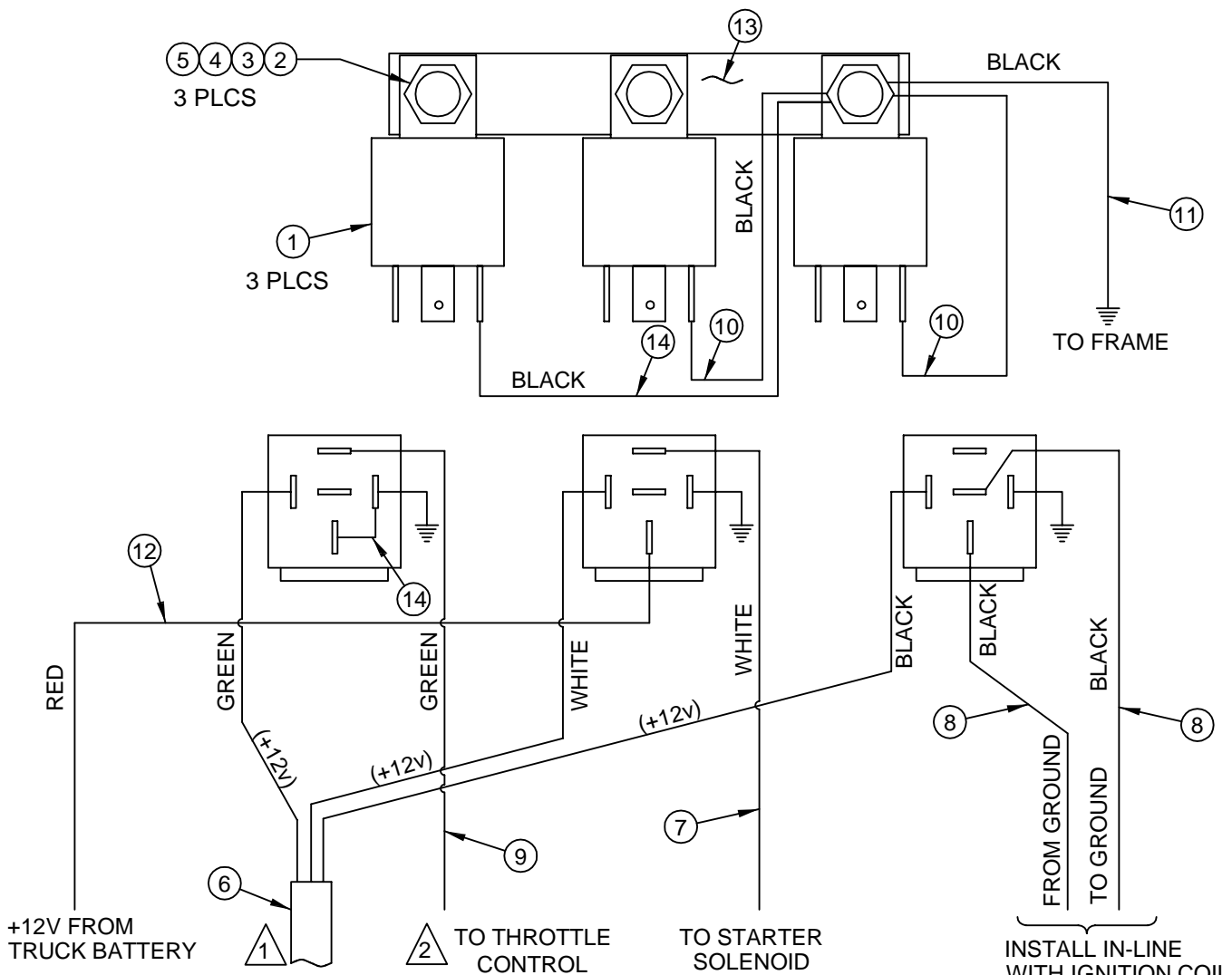

1 USER-CONTROLLED +12V INPUT SIGNALS FROM HETRONIC VLC SYSTEM OR ANALOG PENDANT OR RADIO SYSTEM

2 THROTTLE CONTROL IS DESIGNED TO PROVIDE A GROUND SIGNAL WHEN RELAY IS ACTIVATED

INSTALL IN-LINE WITH IGNITION COIL (GAS) OR FUEL SOLENOID (DIESEL).

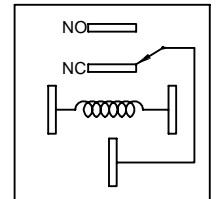

RELAY SCHEMATIC

ITEM	QTY	PART#	DESCRIPTION
1	3	22739	RELAY
2	3	!PHCS#1024075	#10-24 X 3/4 PHIL PAN HD BOLT
3	3	!LWSH-#10	#10 LOCKWASHER
4	3	!FWSH-025	#10 WASHER
5	3	!HNUT-#1024	#10 NUT
6	1	22607	WIRE HARNESS - 12/3 SJO
7	1	22609	WHITE - 16 GAGE ELECTRICAL WIRE - 15 FEET LONG
8	2	22610	BLACK - 16 GAGE ELECTRICAL WIRE - 15 FEET LONG
9	1	22611	GREEN - 16 GAGE ELECTRICAL WIRE - 15 FEET LONG
10	2	22612	BLACK - 16 GAGE ELECTRICAL WIRE - 6 INCHES LONG
11	1	22613	BLACK - 16 GAGE ELECTRICAL WIRE - 8 FEET LONG
12	1	22614	RED - 14 GAGE ELECTRICAL WIRE - 15 FEET LONG
13	1	01181	BUSS BAR
14	1	22619	BLACK - 16GA WIRE ASSY - 6" LONG W/ 3 INCH PIGTAIL



VENCO VENTURO INDUSTRIES LLC
CINCINNATI, OHIO

TITLE ENGINE START / STOP
THROTTLE CONTROL

HT CRANES

DATE 06-09-20F

SUPERSEDES 02-21-14E

SECTION C400

22615

BOOM CAPACITY HT45KX - 20' (7500 lb.)
23462 - RIGHT
23463 - OPPOSITE

BOOM CAPACITY HT45KX - 25' (7800 lb.)
23464 - RIGHT SIDE
23465 - OPPOSITE

BOOM CAPACITY HT45KX - 30' (7800 lb.)
24172 - RIGHT SIDE
24171 - OPPOSITE

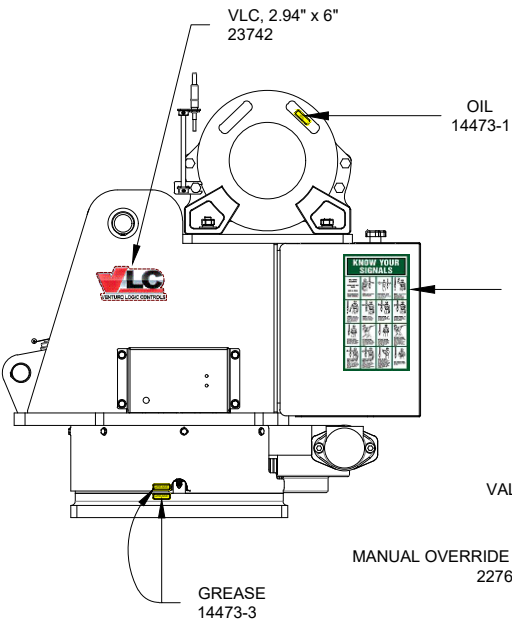
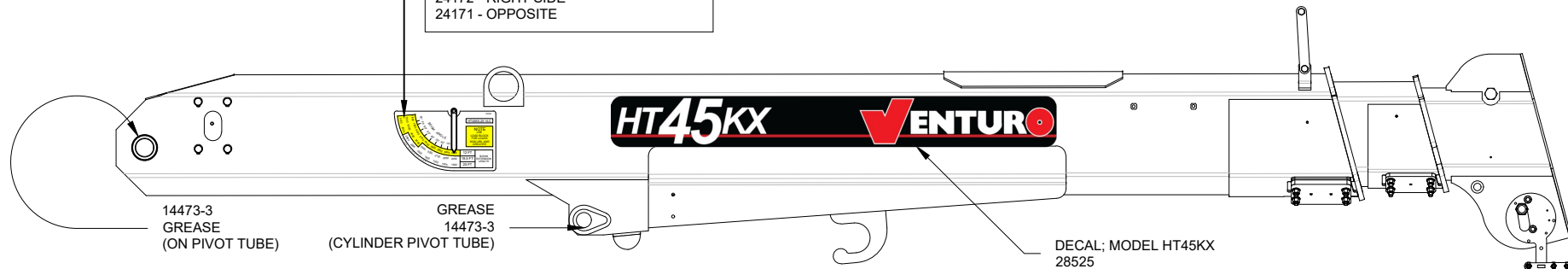

KNOW YOUR SIGNALS
22499

VENTURO (MEDIUM)
17389

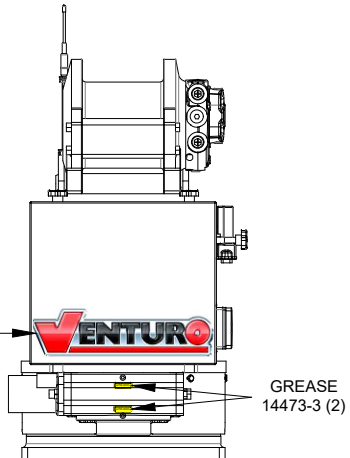

VALVE OVERRIDE
19315-2

MANUAL OVERRIDE (L)
22768-1

MANUAL OVERRIDE (R)
22768-2

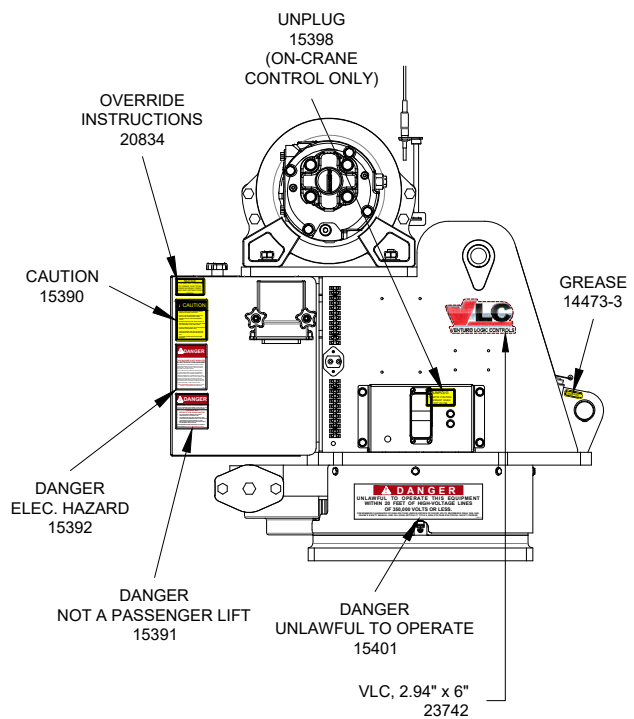
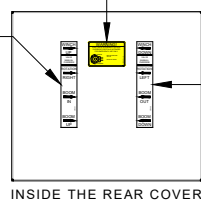

FIELD SERVICE LABEL KITS:
23739 - HT45KX-VLC



VENCO VENTURO INDUSTRIES LLC
CINCINNATI, OHIO

TITLE
DECAL PLACEMENT

HT45KX VLC SERIES

DATE
06-19-23

SUPERSEDES
-

SECTION
C400

28527

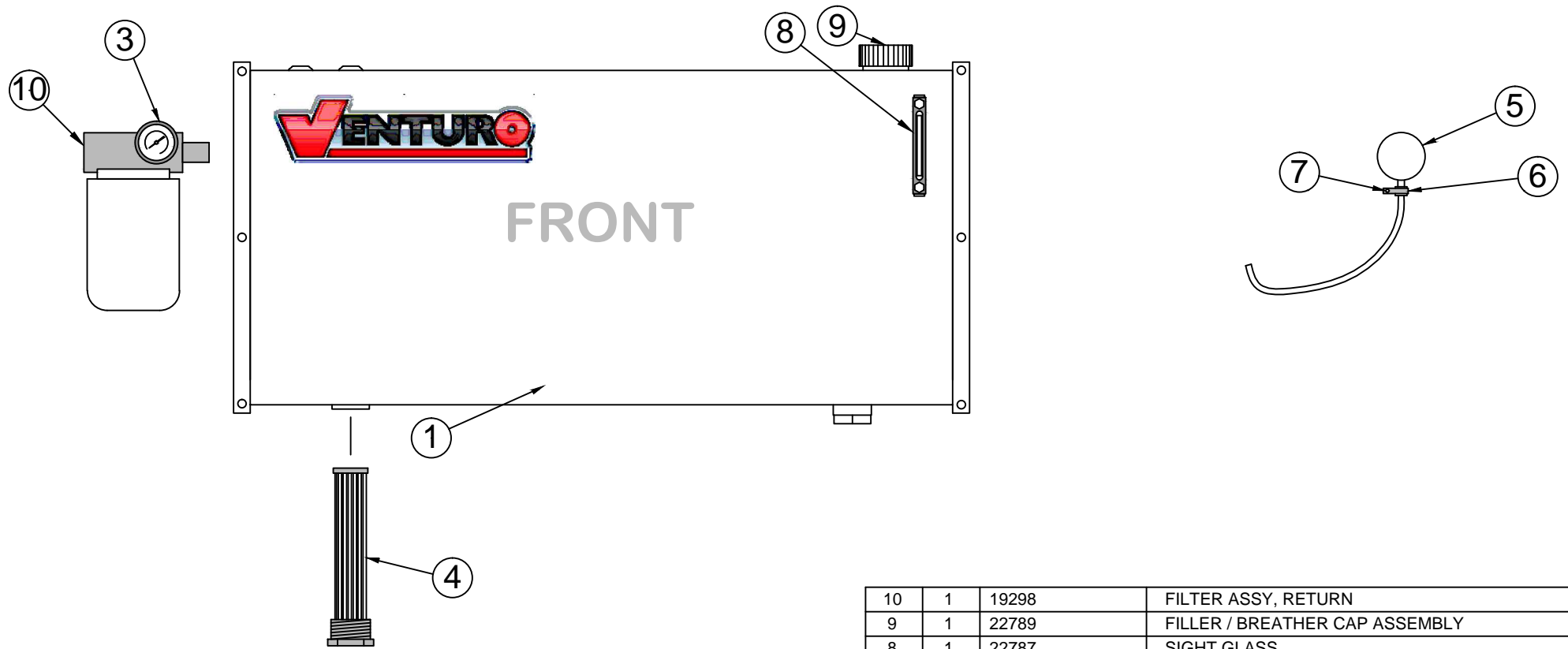

10	1	19298	FILTER ASSY, RETURN
9	1	22789	FILLER / BREATHER CAP ASSEMBLY
8	1	22787	SIGHT GLASS
7	1	!HWHS02520075-F	HEX WASHER HEAD 1/4-20 X 3/4 SELF TAPPING
6	1	19275	CLAMP
5	1	22730	PRESSURE GAUGE ASSEMBLY
4	1	22788	SUCTION SCREEN - 100 MESH
3	1	19297	PRESSURE GAUGE - RETURN
▲ 2	-	-	-
▲ * 1	1	22785	HYDRAULIC RESERVOIR - 25 GAL (18" x 40" x 8")
		22998	HYDRAULIC RESERVOIR - 40 GAL (20" x 42" x 11")
ITEM	QTY	PART NUMBERS	DESCRIPTION



VENCO VENTURO INDUSTRIES LLC
CINCINNATI, OHIO

TITLE

RESERVOIR KIT REPL PARTS

DATE

12-09-22D

SECTION

C400

HT CRANES; 25/40 GAL RESERVOIR

SUPERSEDES

08-04-15C

23224

FIELD SERVICE LABEL KITS; HT45 VLC SERIES

HT45KX			23739 FIELD SERVICE LABEL KITS	
-20 (20' BOOM)	-25 (25' BOOM)	-30 (30' BOOM)		
QTY			PART #	DESCRIPTION
1	1	1	16184-1	DECAL; HORN RELAY
1	1	1	16184-2	DECAL; WORK LIGHT RELAY
2	2	2	28525	DECAL; MODEL HT45KX
1	1	1	17389	DECAL; VENTURO LOGO, MEDIUM
1	1	1	23741	DECAL; VLC MODEL SERIES
1	-	-	23462	DECAL; BOOM CAPACITY, 10-16-20, RIGHT
1	-	-	23463	DECAL; BOOM CAPACITY, 10-16-20, LEFT
-	1	-	23464	DECAL; BOOM CAPACITY, 12-18.5-25, RIGHT
-	1	-	23465	DECAL; BOOM CAPACITY, 12-18.5-25, LEFT
-	-	1	24172	DECAL; BOOM CAPACITY, 13.5-22-30, RIGHT
-	-	1	24171	DECAL; BOOM CAPACITY, 13.5-22-30, LEFT
1	1	1	14473-1	DECAL; OIL
8	8	8	14473-3	DECAL; GREASE
1	1	1	17813	DECAL; OVERLOAD SENSING SYSTEM
1	1	1	22499	DECAL; KNOW YOUR SIGNALS
1	1	1	20834	DECAL; MANUAL OVERRIDE, INSTRUCTIONS
1	1	1	19315-2	DECAL; MANUAL OVERRIDE SHUT-OFF, PROPORTIONAL
1	1	1	22768-1	DECAL; MANUAL OVERRIDE, PROPORTIONAL, LEFT
1	1	1	22768-2	DECAL; MANUAL OVERRIDE, PROPORTIONAL, RIGHT
1	1	1	23766	IDWG: FIELD SERVICE LABEL KIT
1	1	1	28527	IDWG: DECAL PLACEMENT
1	1	1	INST-23233	SAFETY MANUAL, VENTURO CRANES
1	1	1	15397	KIT; ACCIDENTAL PREVENTION SIGNS



VENCO VENTURO INDUSTRIES LLC
CINCINNATI, OHIO

TITLE
FIELD SERVICE LABEL KITS
HT45 VLC SERIES

DATE
07-17-23H
SUPERSEDES
06-19-23G

SECTION
C400
23766



VENTURO CRANES LIMITED WARRANTY POLICY

Venturo products are built to last...we guarantee them.

As a purchaser of any new Venturo product covered by warranty, you will receive 1 year of the most complete coverage available...and, at no added cost to you.

1-Year Limited Warranty Policy

This limited policy warrants new products of Venturo to be free from defects in material and workmanship for a period of one (1) year from date of original installation. OEM products or accessories purchased by Venturo as part of or offered with our product will carry the OEM manufacturer's respective warranty. Our warranty covers:

- ***Repair or replacement of product***
- ***Labor to repair or replace product***
- ***Freight to return and/or replace product***

We shall not be liable for any contingent liabilities arising out of the improper function of any products. Warranty shall become void if the product is improperly installed, modified, damaged, abused or used for application other than intended use. There is no warranty of merchantability, fitness for a particular purpose, warranty arising from course of dealing or usage of trade, or any other implied or expressed warranty, except as made specifically herein. This warranty supersedes all previous warranties, written or implied.

Warranty Claims

Venco Venturo Industries LLC will make a good faith effort for prompt correction or other adjustment with respect to any product, which proves to be defective after our inspection and within the warranty period. Before any repairs are attempted or before returning any product, your Venturo Distributor is required to obtain a warranty claim number. This number is necessary for any claim to be considered. To obtain a warranty claim number, Venturo requires the model and serial number. Only authorized Venturo Distributors can perform warranty. For the name and address of your local Venturo Distributor call the **Warranty Claim Department - 513-772-8448**.

WARNING - It is the responsibility of the installer to ensure the installation is completed according to the manufacturer's recommendations, ensure the ultimate user understands how to operate product in a safe manner, and understands the need for regular service and maintenance by an authorized Venturo Distributor. No modifications or alterations may be made to any Venturo product without the expressed written consent of Venco Venturo Industries LLC. Installation of any Venturo product must be done by an authorized Venturo Distributor, to the standards of the industry; including maintenance, service and affixing of all instruction, safety and warning decals. Users should be instructed as to the safe operation at time of delivery. Maintenance, service, operation and safety warning decals are available on request from Venco Venturo Industries LLC.

VENCO VENTURO INDUSTRIES LLC
12110 BEST PLACE | CINCINNATI, OHIO 45241
P: 800-226-2238 | F: 513-326-5427
www.venturo.com