



VENCO VENTURO INDUSTRIES LLC
12110 BEST PLACE
CINCINNATI, OHIO 45241

Venturo HT Crane Body Exclusive Features

Stainless steel spring-loaded doorkeepers

Prevents damage to the body and adjacent doors. They hold the door open at 90 degrees and keep it from slamming into other doors or the body. They also give the door a self-closing action once the door is pushed within a few inches of closing. These springs give the door a very solid and secure “feel”. Competitors use a crude rod catch mechanism consisting of a painted steel bar with a bend on the end. The rod falls into a hole on a slotted track welded to the door. The rod often misses the hole allowing the door to slam into the body or the adjacent door. Closing the competitor’s door is a 2 handed operation; you must push the rod up with one hand while pushing the door shut with the other.

Dual door weather-stripping in protective channel

Ensures weather-tight compartments. Double panel door construction allows dual gaskets on all doors. The inner automotive type compressible weather-stripping is installed in a protective steel channel. You could actually drag a toolbox, for instance, across the door opening and the channel will completely protect the weather-stripping from damage. Competitors use a simple lip that the weather-stripping is applied to. That same toolbox would drag the weather-stripping right off the lip it is installed on.

Full-length stainless steel piano hinges with concealed attachment hardware

Provides greater security to compartments. The entire hinge is stainless steel including the leaves and pin. The body leaf is attached in the door channel by 6-9 sets of standard hardware in the previously mentioned door channel. The door must be open to even see this hardware. The other leaf is welded to the door. The door is easily replaced without grinding or welding. Competitors use 2) 3” piano hinges that are cut from a longer piece. They are then face riveted to the door and body. Break-in is much easier on the competitor’s body by simply chiseling off 4 rivet heads.

Gutter style drip rail

Ensures weather-tight compartments. The gutter is formed by a channel made from smooth steel and welded under the tread plate compartment tops. The construction is very similar to roof flashing. Water that drips off the compartment tops never even comes in contact with the doors because it is channeled to the back of the body. Competitors use a simple 45-degree



VENCO VENTURO INDUSTRIES LLC
12110 BEST PLACE
CINCINNATI, OHIO 45241

tread plate drip edge that sheds water on to the doors.

Adjustable uni-strut shelf standards

Allows greater flexibility to compartment loading. These infinitely variable track and spring loaded nut mechanisms allow shelves to be placed virtually anywhere in the compartment. Capacity is 350lbs per shelf. Competitors use clips and brackets on predetermined spacing.

CONSTRUCTION

Substructure shall consist of a one-piece continuous longitudinal frame. The curbside rear compartment shall have an integral crane reinforcement up to 40,000 foot-pounds for the HT40 Series and 50,000 foot pounds for the HT50 Series.

The compartment top, back, and bottom shall be constructed of a 14-gauge Jet Kote ASTM A-60 steel sheet. The bulkhead and wheelwell panels shall also be constructed of 12 gauge Jet Kote ASTM A-60 steel sheet. The compartments shall have an integral full compartment length drip rail. The compartment fronts shall be formed so as to have a frame and channel around the perimeter of the opening. The channel shall be continuous and be seal welded at each corner to make a weather tight door seal channel.

The end panels shall be fabricated from 14 gauge Jet Kote ASTM A-60 steel sheet. The end panels shall form the outside front of the compartment frame. The panel shall have ½" outer fold designed to overlap the back & bottom panels of the upper compartments.

On the interior of each compartment sidewall will be two adjustable divider tracks extending the full height. They shall be 14 gauge steel channels approximately 1 ½" wide by 1" deep. The tracks shall allow for placement of shelving and accessories at any point in the track. Shelving packages shall have spring-loaded nuts in order to bolt accessories along the track.

A continuous black closed cell neoprene, D-shaped open center door gasket with adhesive back shall be installed in the compartment door channel. A sectional door gasket, foam, or closed center door gasket is not acceptable.

DIAMOND PLATE BED FLOOR

Deck is to be 10-gauge diamond plate steel. The deck will have a 2" bend along both inner sidewalls. There will be no wheel riser boxes in deck area.



VENCO VENTURO INDUSTRIES LLC
12110 BEST PLACE
CINCINNATI, OHIO 45241

COMPARTMENT DOORS

The doors shall be double panel lap type. The out panel shall be 14 gauge Jet Kote ASTM A-60 steel sheet. The inner panel shall be 18 gauge Jet Kote ASTM A-60 steel sheet. The inner panel shall be welded to the outer panel and a full width reinforcement channel shall be attached to both the inner and outer panels. The inner panel will be precisely sized so as to make contact with the upper compartment perimeter door seal gasket. The inner panel shall make contact with the door seal continuously around the entire perimeter of the compartment when the door is closed.

The door shall be equipped with a full-length stainless steel continuous piano hinge with a 3/16" stainless steel pin. The hinge shall be welded to the door between the inner & outer panels. The hinge will be bolted to the compartment inner frame so that there are no fasteners visible on the door or the compartment when the door is closed.

All doors shall be equipped with three point keyed-alike premium ergonomic Eberhard compression door handle. The Eberhard handle shall have a cylindrical lock with a barrel type key. The Eberhard handle will have two full door width zinc plated rods to allow for a positive three-point latch system.

Each vertically hinged door will have an over-center spring door check to maintain the door at a 90 angle to the body when open.

Each horizontally hinged door will have a heavy-duty chain encased in an anti-rattle sheath. The chain will be welded to a compartment frame reinforcement bracket and have a detachable "S" hook on the door end that will hold the door open at 90 to the body, or allow the door to swing down 180.

TAILGATE

There shall be a fold down rear tailgate sized to the full width of the bed opening. The gate shall have right-hand and left-hand zinc plated tailgate latches and hinges equipped with grease fittings.

FINISH

There shall be full undercoating and prime paint on all exterior and compartment interior surfaces.

HT 66-132-DTF-WBB

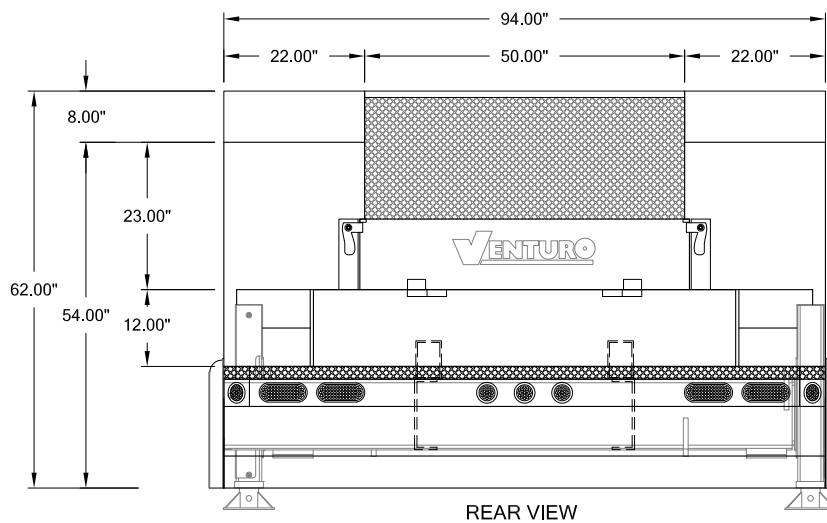
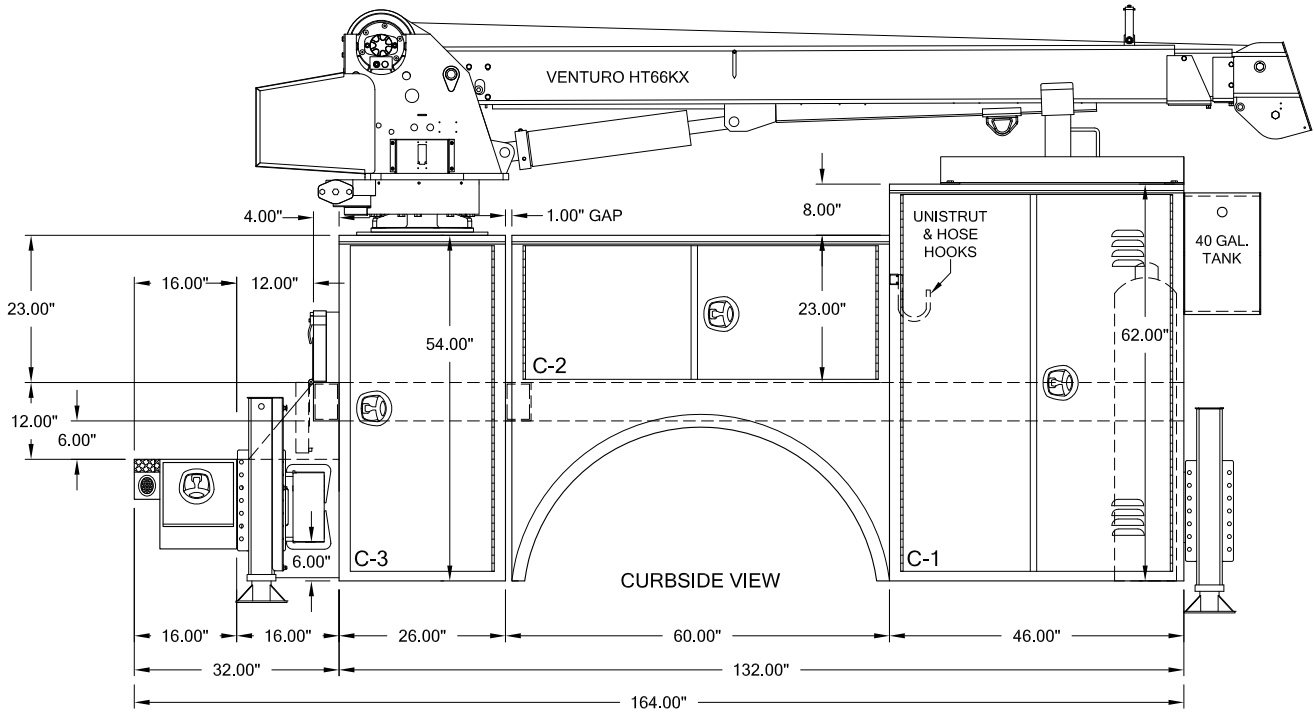
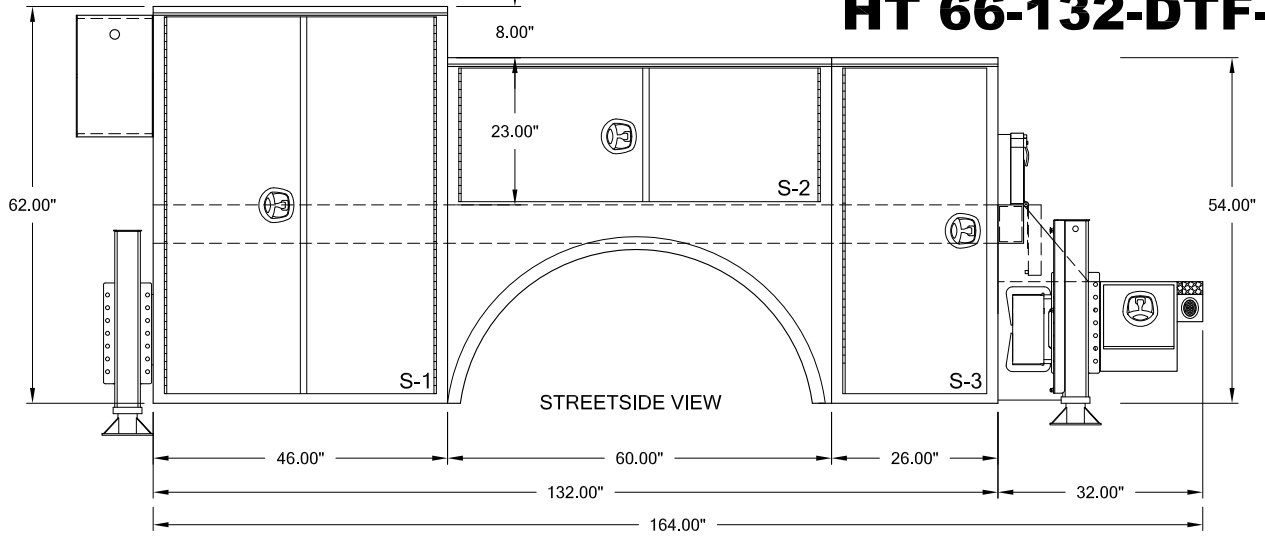

VENTURO CRANE BODIES

HT 66-132-DTF-WBB

SCALE: N.T.S.

DATE: 04/15/2010

SHEET: 1 OF 1

REV.	DATE

HT 66-163-DTF-WBB

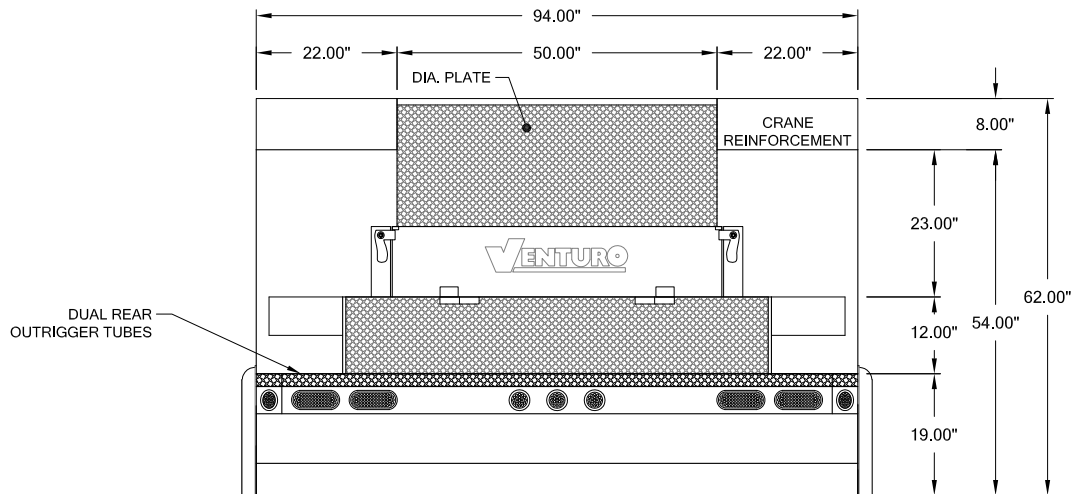
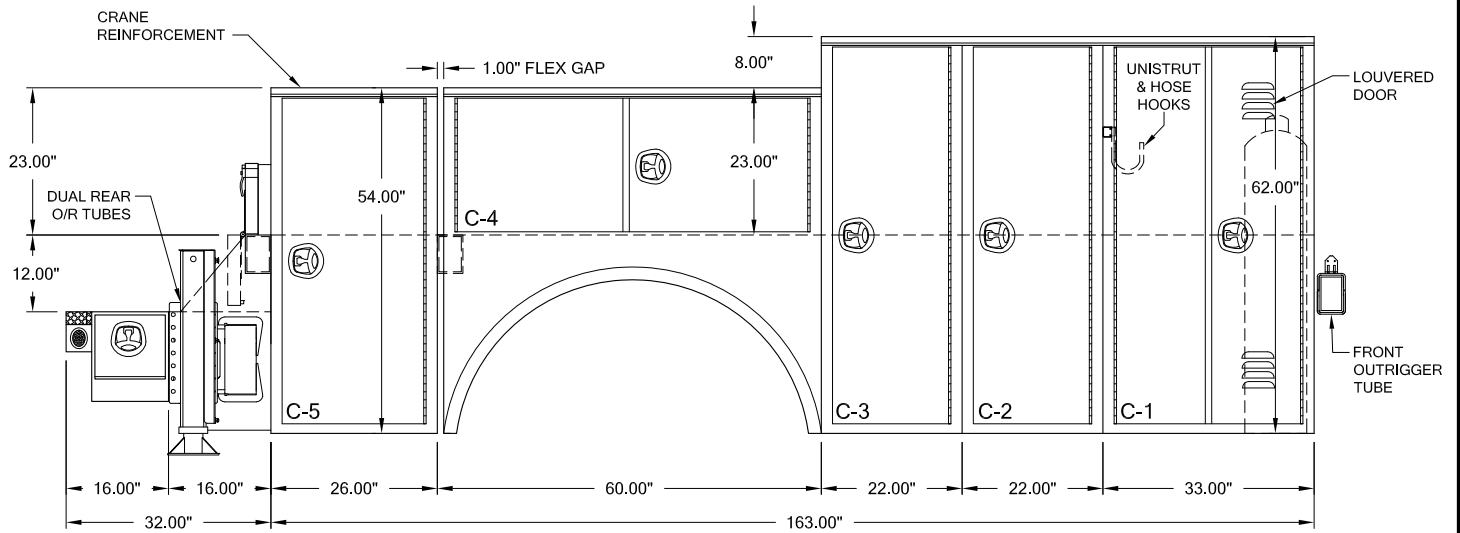
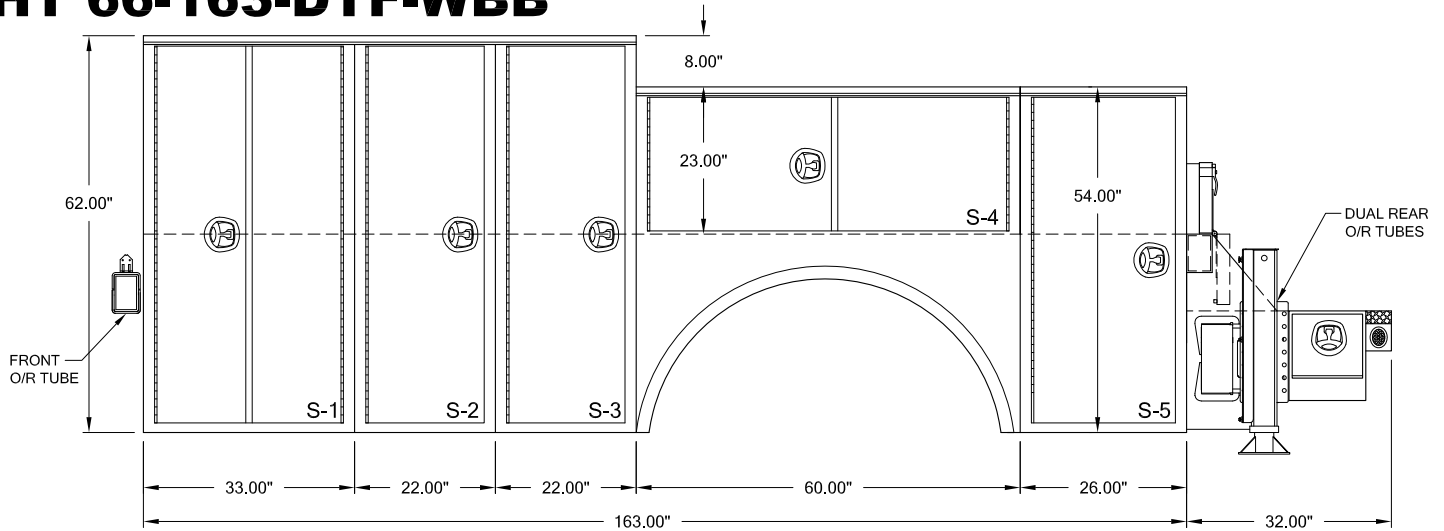

NOTES:

- 10 GA. DIAMOND PLATE STEEL BED WALL & COMP'T TOPS
- 12 GA. & 14 GA. JET KOTE GALVANEAL STEEL BODY
- DOUBLE PANEL JET KOTE GALVANEAL STEEL DOORS W/ SPRING DOOR CHECKS
- FLAT 1/8" DIAMOND PLATE DECK WITHOUT WHEEL WELLS
- FULL LENGTH STAINLESS STEEL PIANO HINGE, PIN & T-HANDLE LATCHES W/ LOCKS
- FULL LENGTH DRIP RAIL OVER ALL COMP'T DOORS
- UNOBSTRUCTED CRANE REINFORCED COMPARTMENTS
- TUBULAR LONGITUDINAL FRAME & CRANE COMPARTMENT CROSS MEMBERS
- AUTOMOTIVE TYPE DOOR SEALS & BODY UNDERCOATING



VENTURO CRANE BODIES

HT 66-163-DTF-WBB

SCALE:
N.T.S.

DATE:
01/03/2010

SHEET:
1 OF 1

REV.	DATE

0 01/03/2010