

# HT 40-131-FLT

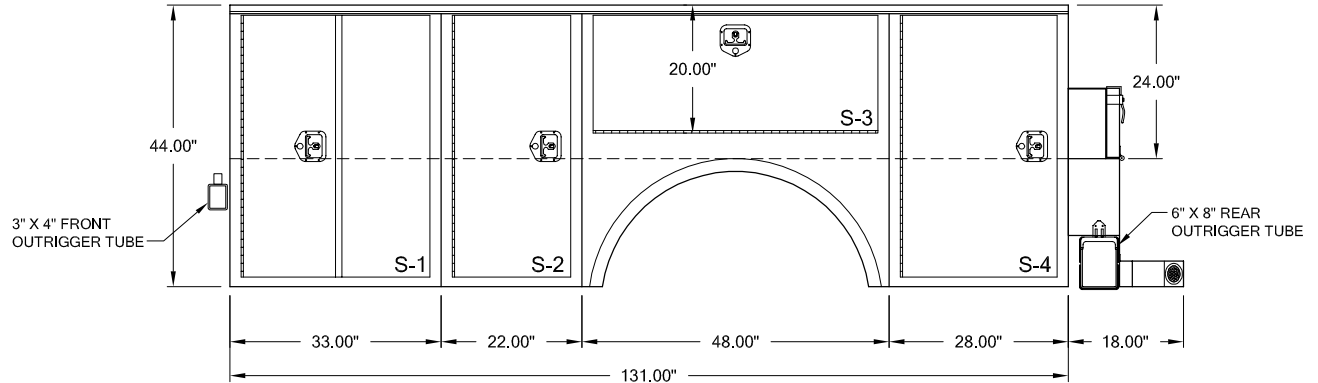

STREET SIDE VIEW

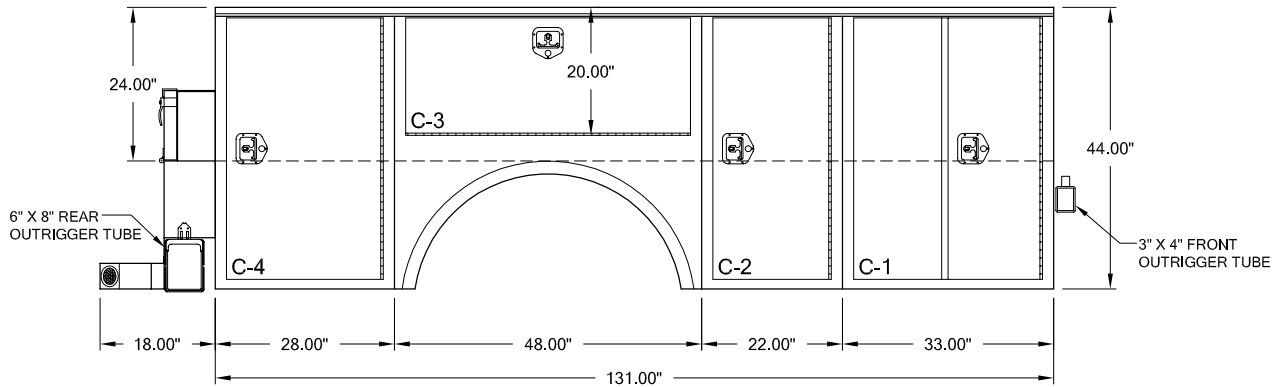

CURB SIDE VIEW

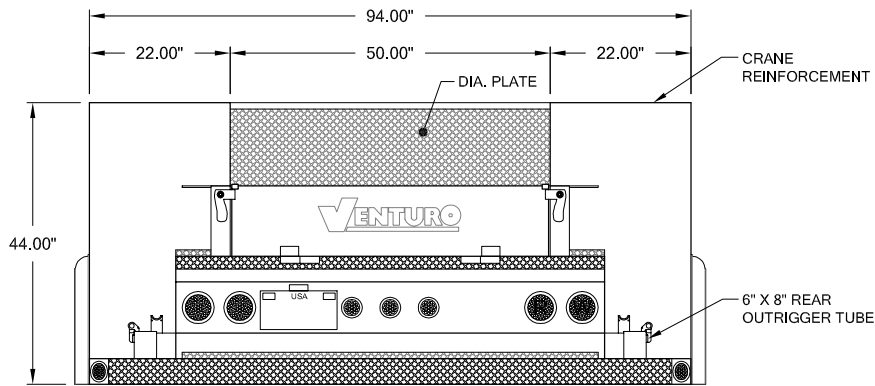

REAR VIEW

**NOTES:**

- 10 GA. DIAMOND PLATE STEEL BED WALL & COMP'T TOPS
- 12 GA. & 14 GA. JET KOTE GALVANEAL STEEL BODY
- DOUBLE PANEL JET KOTE GALVANEAL STEEL DOORS W/ SPRING DOOR CHECKS
- FLAT 1/8" DIAMOND PLATE DECK WITHOUT WHEEL WELLS
- FULL LENGTH STAINLESS STEEL PIANO HINGE, PIN & T-HANDLE LATCHES W/ LOCKS
- FULL LENGTH DRIP RAIL OVER ALL COMPARTMENT DOORS
- UNOBSTRUCTED CRANE REINFORCED COMPARTMENTS
- TUBULAR LONGITUDINAL FRAME & CRANE COMPARTMENT CROSS MEMBERS
- AUTOMOTIVE TYPE DOOR SEALS & BODY UNDERCOATING

CLEAR DOOR OPENINGS

- S-1/C-1 = 38.00"H X 27.00"W
- S-2/C-2 = 38.00"H X 16.00"W
- S-3/C-3 = 16.00"H X 42.00"W
- S-4/C-4 = 38.00"H X 22.00"W



VENTURO CRANE BODIES

HT 40-131-FLT

SCALE:  
N.T.S.

DATE:  
09/30/2005

SHEET:  
1 OF 1

REV.	DATE

# HT 40-131-TFC

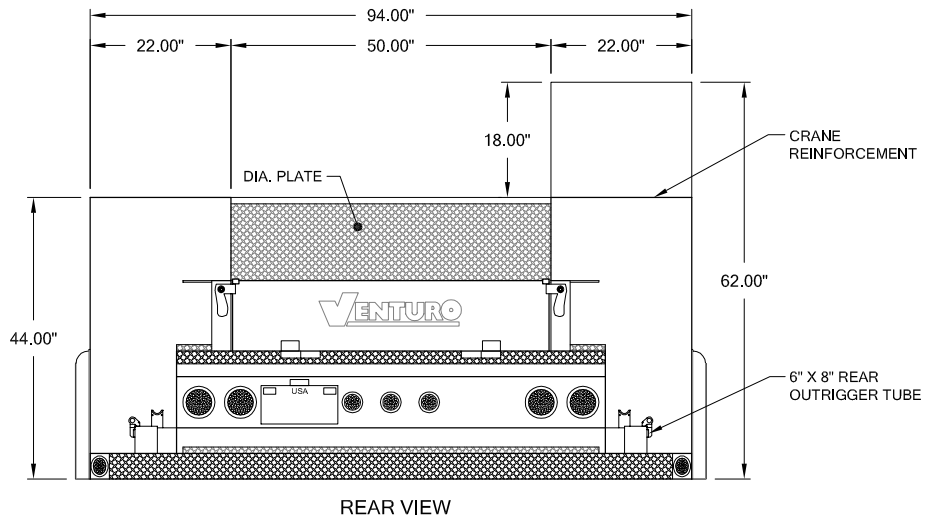
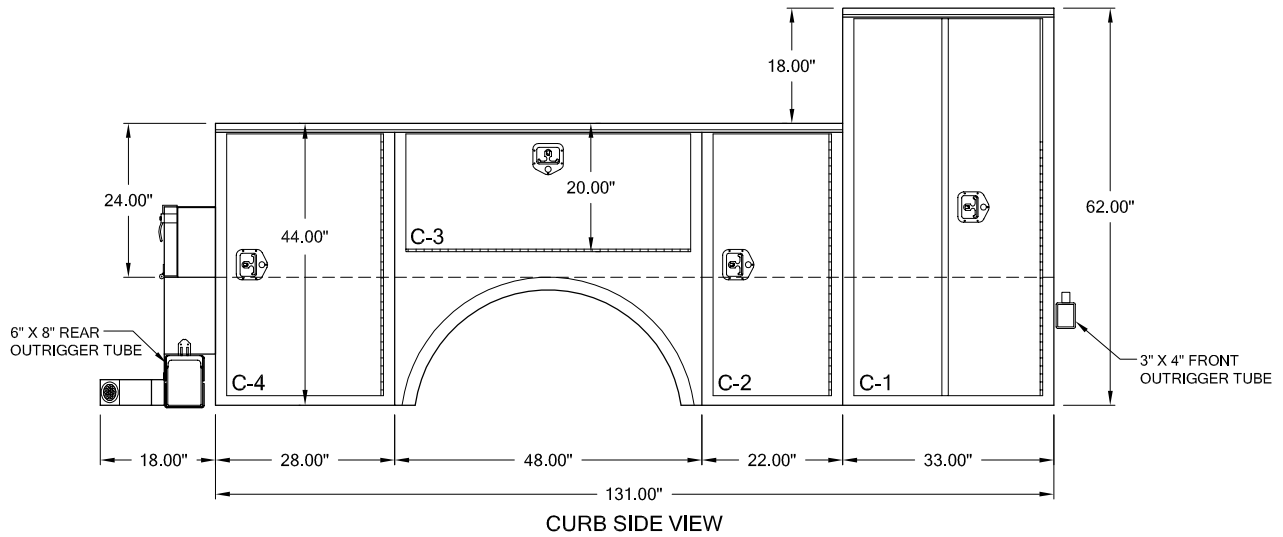
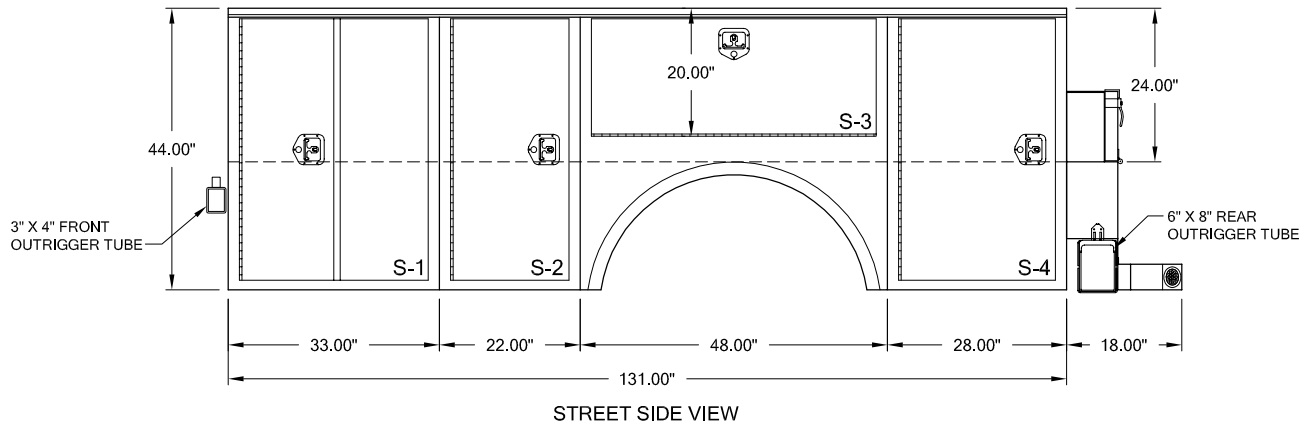

**NOTES:**

- 10 GA. DIAMOND PLATE STEEL BED WALL & COMP'T TOPS
- 12 GA. & 14 GA. JET KOTE GALVANEAL STEEL BODY
- DOUBLE PANEL JET KOTE GALVANEAL STEEL DOORS W/ SPRING DOOR CHECKS
- FLAT 1/8" DIAMOND PLATE DECK WITHOUT WHEEL WELLS
- FULL LENGTH STAINLESS STEEL PIANO HINGE, PIN & T-HANDLE LATCHES W/ LOCKS
- FULL LENGTH DRIP RAIL OVER ALL COMPARTMENT DOORS
- UNOBSTRUCTED CRANE REINFORCED COMPARTMENTS
- TUBULAR LONGITUDINAL FRAME & CRANE COMPARTMENT CROSS MEMBERS
- AUTOMOTIVE TYPE DOOR SEALS & BODY UNDERCOATING

CLEAR DOOR OPENINGS

S-1 = 38.00"H X 27.00"W	C-1 = 56.00"H X 27.00"W
S-2 = 38.00"H X 16.00"W	C-2 = 38.00"H X 16.00"W
S-3 = 16.00"H X 42.00"W	C-3 = 16.00"H X 42.00"W
S-4 = 38.00"H X 22.00"W	C-4 = 38.00"H X 22.00"W



VENTURO CRANE BODIES

HT 40-131-TFC

SCALE:  
N.T.S.

DATE:  
09/30/2005

SHEET:  
1 OF 1

REV.	DATE

# HT 40-131-DTF

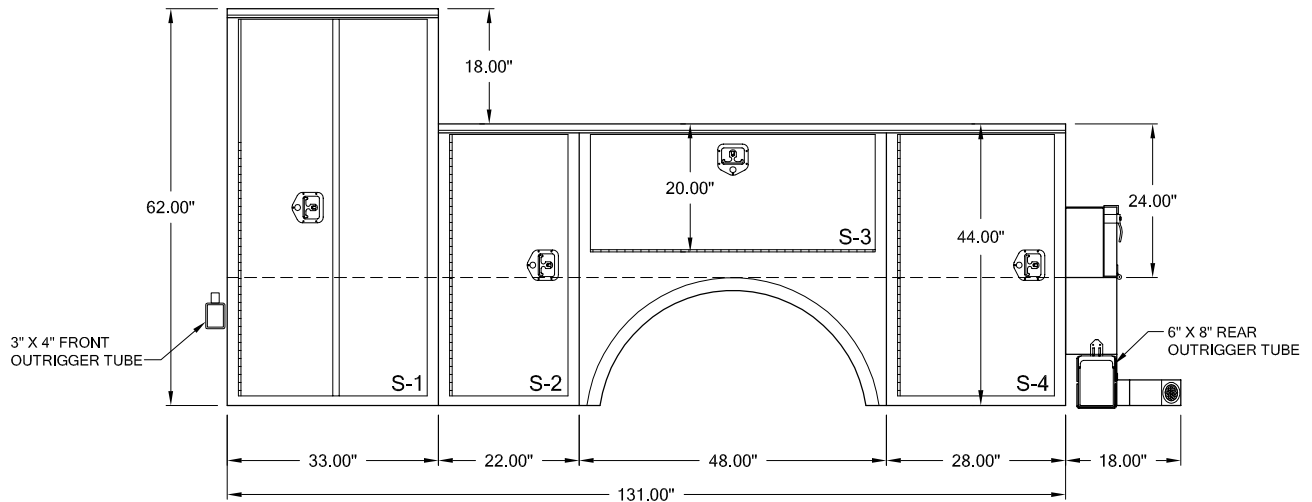

STREET SIDE VIEW

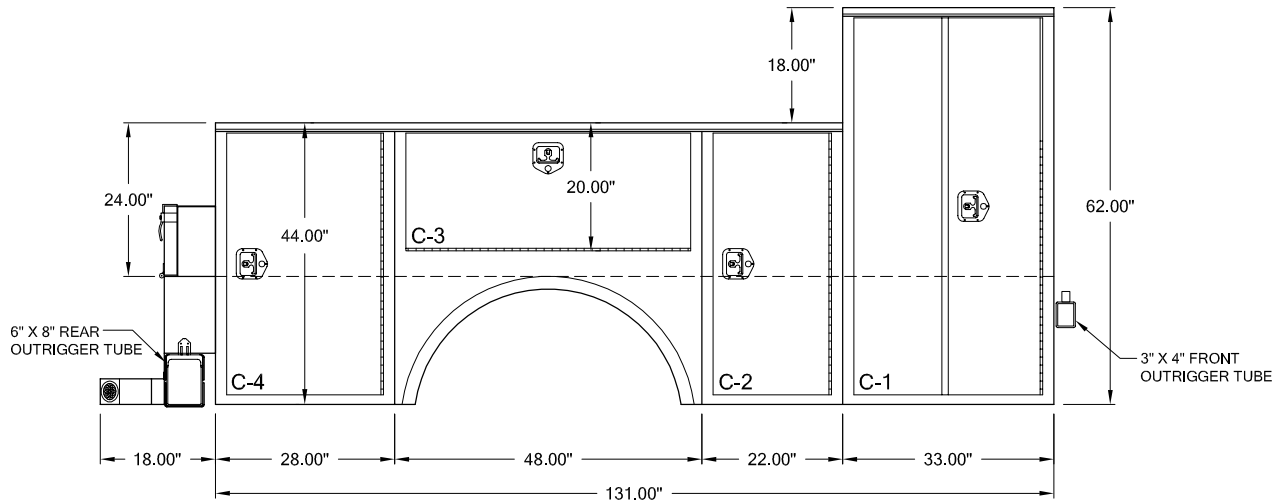

CURB SIDE VIEW

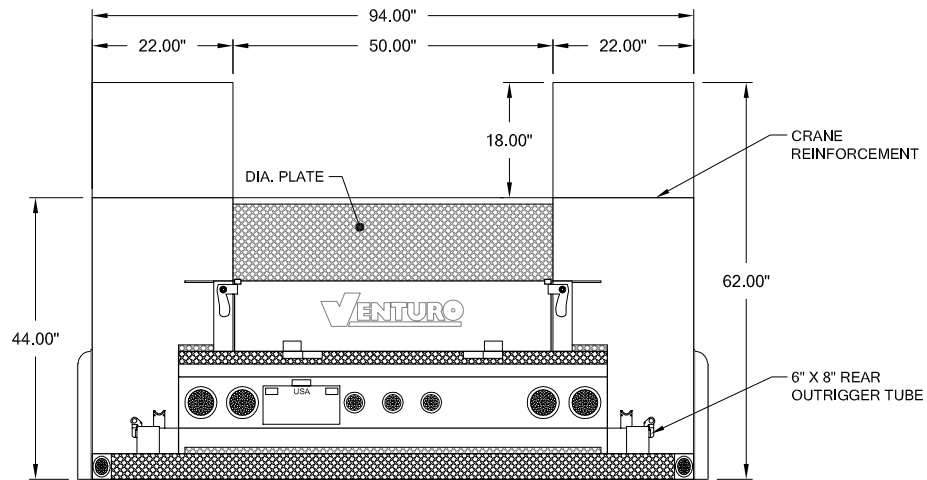

REAR VIEW

**NOTES:**

- 10 GA. DIAMOND PLATE STEEL BED WALL & COMP'T TOPS
- 12 GA. & 14 GA. JET KOTE GALVANEAL STEEL BODY
- DOUBLE PANEL JET KOTE GALVANEAL STEEL DOORS W/ SPRING DOOR CHECKS
- FLAT 1/8" DIAMOND PLATE DECK WITHOUT WHEEL WELLS
- FULL LENGTH STAINLESS STEEL PIANO HINGE, PIN & T-HANDLE LATCHES W/ LOCKS
- FULL LENGTH DRIP RAIL OVER ALL COMPARTMENT DOORS
- UNOBSTRUCTED CRANE REINFORCED COMPARTMENTS
- TUBULAR LONGITUDINAL FRAME & CRANE COMPARTMENT CROSS MEMBERS
- AUTOMOTIVE TYPE DOOR SEALS & BODY UNDERCOATING

CLEAR DOOR OPENINGS

- S-1/C-1 = 56.00"H X 27.00"W
- S-2/C-2 = 38.00"H X 16.00"W
- S-3/C-3 = 16.00"H X 42.00"W
- S-4/C-4 = 38.00"H X 22.00"W



VENTURO CRANE BODIES

HT 40-131-DTF

SCALE: N.T.S. DATE: 09/30/2005 SHEET: 1 OF 1

REV: DATE

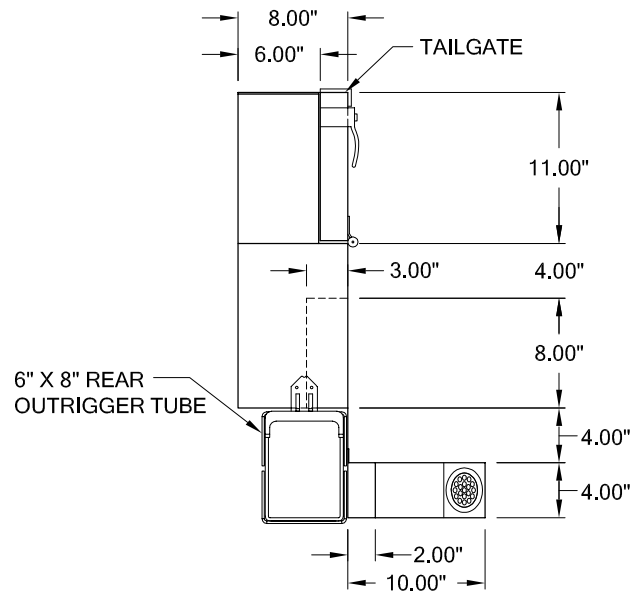
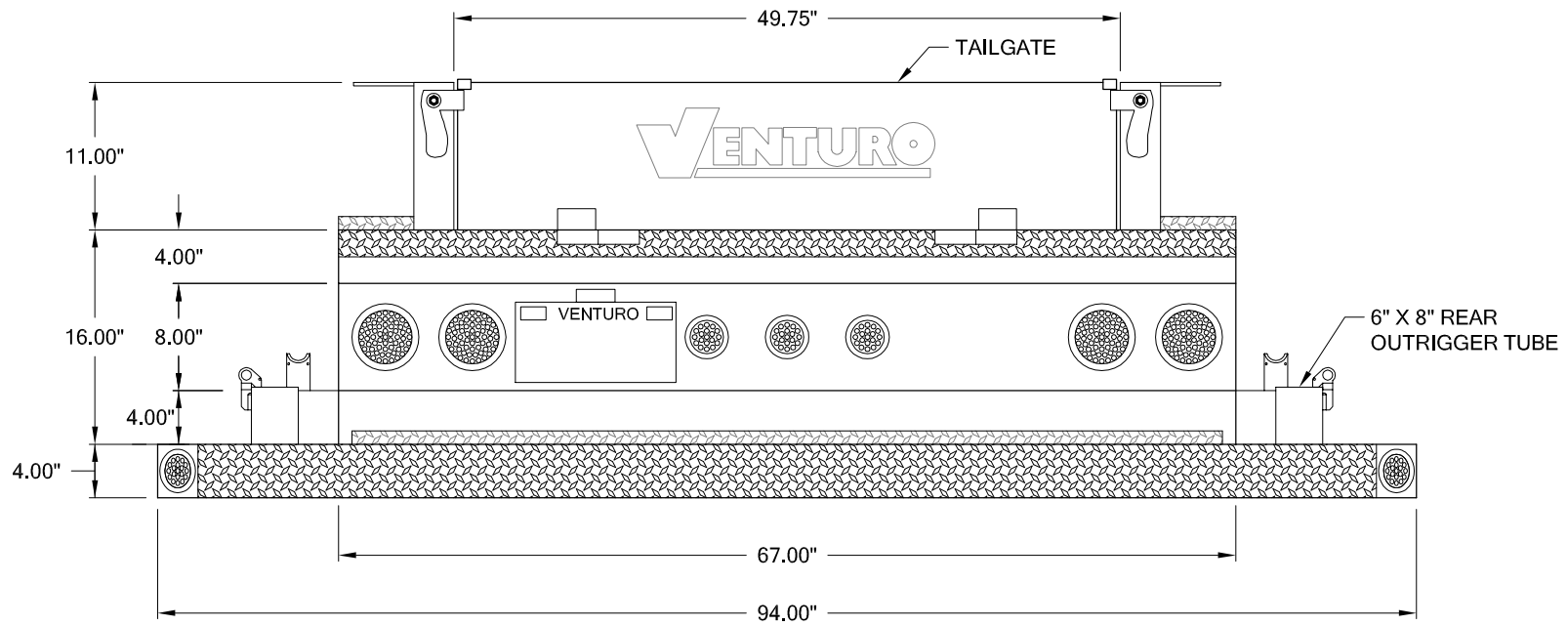

HT40 SERIES - CRANE BODY

STANDARD BUMPER

SCALE:  
N.T.S.

DATE:  
09/07/2005

SHEET:  
1 OF 1

REV.	DATE

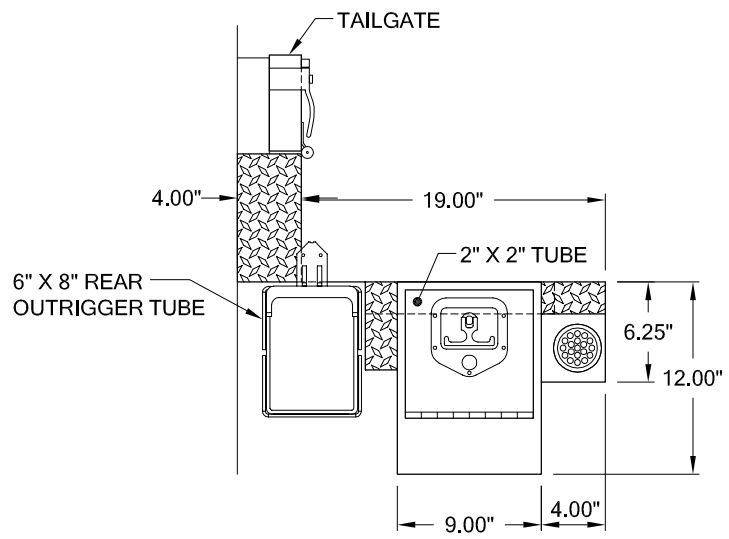
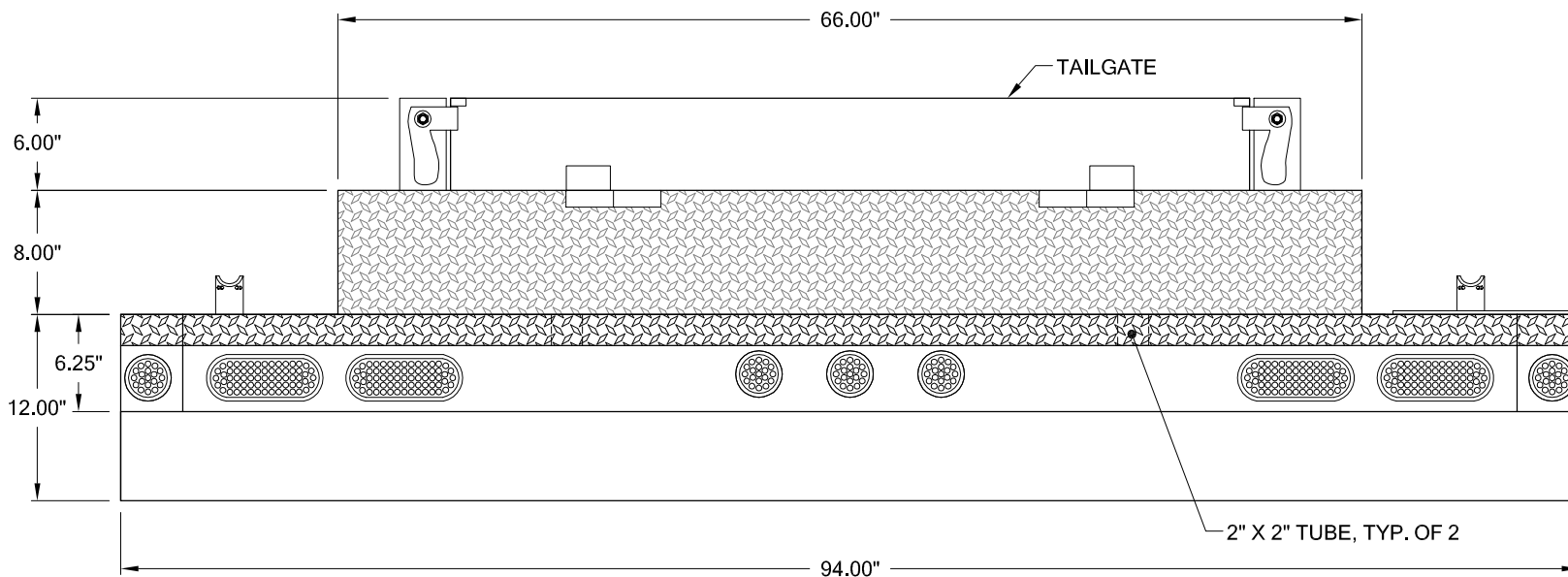

HT40 SERIES - CRANE BODY			REV.	DATE
WBB - 40 DD				
SCALE:	DATE:	SHEET:		
N.T.S.	09/07/2005	1 OF 1		

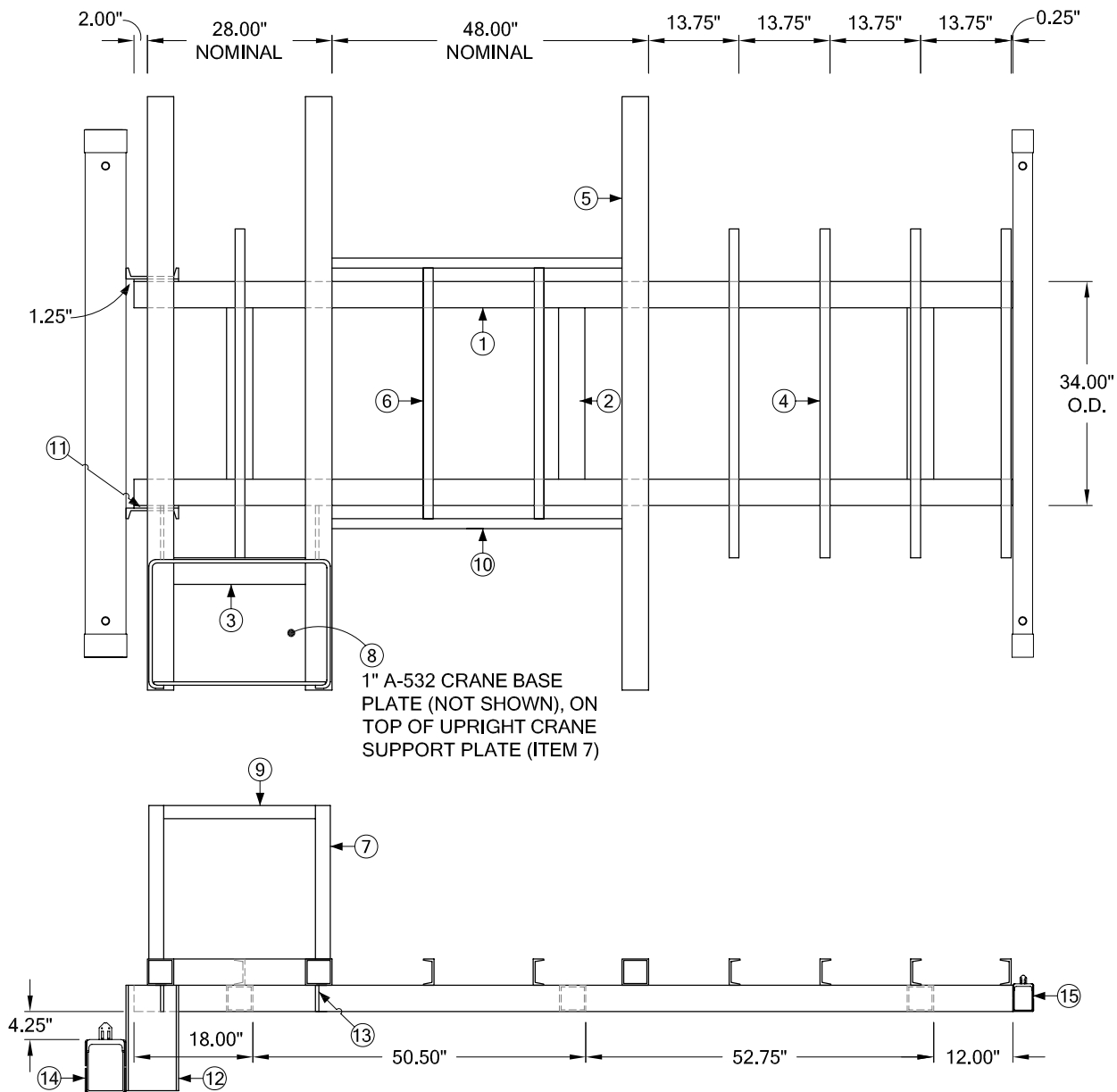

ITEM	QTY	DESCRIPTION
1	2	4" x 4" x .250 RECT. STEEL TUBE= 133.25"L
2	3	4" x 4" x .250 RECT. STEEL TUBE= 26"L
3	1	4" x 4" x .250 RECT. STEEL TUBE= 20"L
4	5	C4 x 5.4 STRUCT. STEEL CHANNEL= 49-7/8"L
5	3	4" x 4" x .250 RECT. STEEL TUBE = 90"L
6	2	C4 x 5.4 STRUCT. STEEL CHANNEL= 38"L
7	1	1/2" x 23.25"H A-36 STEEL PLATE UPRIGHT CRANE SUPPORT
8	1	1" x 20" x 27.50" A-532 CRANE BASE PLATE. (NOT SHOWN)
9	1	3" x 1/2" STEEL FLAT BAR = 26"L
10	2	C4 x 5.4 STRUCT. STEEL CHANNEL = 44"L
11	2	3/8" x 4" x 6" STEEL PLATE SPACER
12	2	C8 x 11.5 STRUCT. STEEL CHANNEL = 16"L
13	1	1/2" x 4" STEEL FLAT BAR 8"L
14	1	6" x 8" OUTRIGGER - REAR
15	2	3" x 4" OUTRIGGER - FRONT



VENTURO CRANE BODY		REV.	DATE
HT 40-131 STD. SUB-FRAME			
SCALE:	DATE:	SHEET:	
N.T.S.	08/08/2006	1 OF 1	
		0	04/04/2006
		1	08/08/2006